



# **DEEP SEA ELECTRONICS**

## **DSE8610 MKII Configuration Suite**

### **PC Software Manual**

**Document Number: 057-238**

Author: Ashley Senior





**Deep Sea Electronics Ltd.**

Highfield House  
Hunmanby  
North Yorkshire  
YO14 0PH  
England

**Sales Tel:** +44 (0) 1723 890099

**E-mail:** [sales@deepseaelectronics.com](mailto:sales@deepseaelectronics.com)

**Website:** [www.deepseaelectronics.com](http://www.deepseaelectronics.com)

**DSE8610 MKII Configuration Suite PC Software Manual**

© Deep Sea Electronics Ltd.

All rights reserved. No part of this publication may be reproduced in any material form (including photocopying or storing in any medium by electronic means or other) without the written permission of the copyright holder except in accordance with the provisions of the Copyright, Designs and Patents Act 1988.

Applications for the copyright holder's written permission to reproduce any part of this publication must be addressed to Deep Sea Electronics Ltd. at the address above.

The DSE logo and the names DSEGenSet®, DSEATS®, DSEPower® and DSEControl® are UK registered trademarks of Deep Sea Electronics Ltd.

Any reference to trademarked product names used within this publication is owned by their respective companies.

Deep Sea Electronics Ltd. reserves the right to change the contents of this document without prior notice.

**Amendments Since Last Publication**

Amd. No.	Comments
1	Initial release
2	Added information about Reset Electrical Trip
3	Added updates to configuring sensor curves, fuel usage alarm, fuel use and efficiency, J1939-75, DTC/SPN ignore, DEF level alarm and post heat timer.
4	Updated to include features added in module firmware v2.0 and v3.0
5	Updated to include features added in module firmware V4 and V5.0
6	Updated to include features added in module firmware V5.1
7	Updated to include features added in module firmware V6.1
8	Updated to module firmware V7.0, features include: Load Demand Compatibility option, CAN AVR comms, MSC PLC Data, and more...

Typeface: The typeface used in this document is *Arial*. Care must be taken not to mistake the upper case letter I with the numeral 1. The numeral 1 has a top serif to avoid this confusion.

## TABLE OF CONTENTS

Section	Page
<b>1 INTRODUCTION.....</b>	<b>7</b>
<b>1.1 CLARIFICATION OF NOTATION.....</b>	<b>8</b>
<b>1.2 GLOSSARY OF TERMS.....</b>	<b>8</b>
<b>1.3 BIBLIOGRAPHY .....</b>	<b>10</b>
1.3.1 INSTALLATION INSTRUCTIONS.....	10
1.3.2 MANUALS .....	11
1.3.3 TRAINING GUIDES .....	12
1.3.4 THIRD PARTY DOCUMENTS .....	13
<b>1.4 INSTALLATION AND USING THE DSE CONFIGURATION SUITE SOFTWARE .....</b>	<b>13</b>
<b>2 EDITING THE CONFIGURATION .....</b>	<b>14</b>
<b>2.1 SCREEN LAYOUT .....</b>	<b>14</b>
<b>2.2 MODULE .....</b>	<b>15</b>
2.2.1 MODULE OPTIONS.....	15
2.2.2 CONFIGURABLE STATUS SCREENS .....	20
2.2.3 EVENT LOG.....	22
2.2.3.1 ENGINE DTC LOGGING .....	24
2.2.4 DATA LOGGING .....	25
2.2.4.1 CONFIGURATION .....	26
2.2.4.2 OPTIONS .....	27
<b>2.3 APPLICATION .....</b>	<b>28</b>
<b>2.4 INPUTS.....</b>	<b>30</b>
2.4.1 ANALOGUE INPUT CONFIGURATION .....	30
2.4.2 ANALOGUE INPUTS .....	32
2.4.2.1 CREATING / EDITING THE SENSOR CURVE.....	35
2.4.3 DIGITAL INPUTS .....	37
2.4.3.1 DIGITAL INPUTS .....	37
2.4.3.2 ANALOGUE INPUTS .....	39
2.4.3.3 INPUT FUNCTIONS .....	40
<b>2.5 OUTPUTS.....</b>	<b>46</b>
2.5.1 DIGITAL OUTPUTS .....	46
2.5.2 VIRTUAL LEDS.....	47
2.5.3 OUTPUT SOURCES.....	48
<b>2.6 TIMERS .....</b>	<b>61</b>
2.6.1 START TIMERS .....	61
2.6.2 LOAD / STOPPING TIMERS .....	63
2.6.3 MODULE TIMERS .....	64
<b>2.7 GENERATOR.....</b>	<b>65</b>
2.7.1 GENERATOR OPTIONS .....	66
2.7.2 GENERATOR RATING .....	68
2.7.3 GENERATOR DE-RATE .....	69
2.7.4 GENERATOR VOLTAGE.....	70
2.7.5 GENERATOR FREQUENCY.....	72
2.7.6 GENERATOR CURRENT .....	74
2.7.6.1 GENERATOR CURRENT OPTIONS .....	74
2.7.6.2 GENERATOR CURRENT ALARMS.....	75
2.7.6.2.1 DEFAULT CURRENT PROTECTION TRIPPING CHARACTERISTICS.....	85
2.7.7 GENERATOR POWER .....	87
2.7.7.1 OVERLOAD PROTECTION.....	88
2.7.7.2 LOAD CONTROL.....	89
2.7.7.3 REVERSE POWER .....	91
2.7.7.4 LOW LOAD .....	91
2.7.8 MAINS DECOUPLING .....	92
2.7.8.1 LOSS OF MAINS .....	93
2.7.8.2 VOLTAGE ALARMS .....	94
2.7.8.3 FREQUENCY.....	96

2.7.9	SYNCHRONISING .....	98
2.7.9.1	SYNC OPTIONS .....	99
2.7.9.2	CHECK SYNC.....	103
2.7.9.3	MSC LINK .....	105
2.7.9.4	LOAD CONTROL.....	107
2.7.9.4.1	CREATING / EDITING THE DROOP CURVE .....	118
2.7.9.5	AVR.....	119
2.7.9.6	POWER CONTROL .....	121
2.7.9.6.1	CREATING / EDITING THE POWER MODE CURVE .....	124
2.7.9.7	VOLTAGE AND REACTIVE POWER CONTROL .....	125
2.7.10	BUS .....	128
2.7.11	FAULT RIDE THROUGH .....	129
<b>2.8</b>	<b>ENGINE.....</b>	<b>132</b>
2.8.1	ENGINE PROTECTION .....	133
2.8.2	OIL PRESSURE .....	134
2.8.3	COOLANT TEMPERATURE.....	135
2.8.3.1	COOLANT TEMPERATURE ALARM .....	135
2.8.3.2	COOLANT TEMPERATURE CONTROL.....	137
2.8.4	FUEL LEVEL .....	138
2.8.4.1	FUEL CONTROL AND MONITORING .....	139
2.8.4.2	FUEL ALARMS .....	143
2.8.5	FUEL USE AND EFFICIENCY.....	146
2.8.6	DEF LEVEL .....	148
2.8.7	ENGINE OPTIONS .....	149
2.8.8	ECU (ECM) OPTIONS .....	151
2.8.9	ECU (ECM) ALARMS.....	154
2.8.9.1	ECU (ECM) DATA FAIL .....	154
2.8.9.2	DM1 SIGNALS .....	155
2.8.9.3	ADVANCED .....	159
2.8.9.4	MESSAGE FAILURE .....	162
2.8.10	GAS ENGINE OPTIONS.....	162
2.8.11	CRANKING.....	163
2.8.12	IDLE SETTING .....	165
2.8.13	SPEED SENSING .....	166
2.8.14	SPEED SETTINGS .....	167
2.8.15	PLANT BATTERY .....	169
2.8.16	INLET TEMPERATURE .....	170
2.8.17	ENGINE ICON DISPLAYS .....	171
2.8.17.1	TITLE INSTRUMENTATION.....	172
2.8.17.2	ICON INSTRUMENTATION.....	173
<b>2.9</b>	<b>COMMUNICATIONS.....</b>	<b>176</b>
2.9.1	COMMUNICATIONS OPTIONS.....	176
2.9.2	RS232 PORT.....	177
2.9.2.1	BASIC.....	178
2.9.2.2	ADVANCED .....	181
2.9.2.3	SMS CONTROL.....	183
2.9.2.4	TROUBLESHOOTING MODEM COMMUNICATIONS .....	184
2.9.2.4.1	MODEM COMMUNICATION SPEED SETTING.....	184
2.9.2.4.2	GSM MODEM CONNECTION .....	184
2.9.3	RS485 PORTS .....	185
2.9.4	ETHERNET .....	186
2.9.4.1	FIREWALL CONFIGURATION FOR INTERNET ACCESS .....	188
2.9.4.2	INCOMING TRAFFIC (VIRTUAL SERVER).....	188
2.9.5	NOTIFICATIONS.....	189
2.9.5.1	SNMP .....	189
2.9.5.2	NOTIFICATIONS .....	190
<b>2.10</b>	<b>SCHEDULER.....</b>	<b>191</b>
2.10.1	SCHEDULER OPTIONS .....	191
2.10.2	BANK 1 / BANK 2.....	192
<b>2.11</b>	<b>MAINTENANCE ALARM .....</b>	<b>193</b>

<b>2.12</b>	<b>CONFIGURABLE CAN INSTRUMENTATION</b> .....	<b>194</b>
2.12.1	RECEIVED INSTRUMENTATION (1-30) .....	195
2.12.1.1	DETAILS .....	196
2.12.2	TRANSMITTED INSTRUMENTATION .....	198
2.12.2.1	DETAILS .....	198
2.12.3	EXPORT / IMPORT CONFIGURABLE CAN .....	200
<b>2.13</b>	<b>ALTERNATIVE CONFIGURATIONS</b> .....	<b>201</b>
2.13.1	ALTERNATIVE CONFIGURATION OPTIONS .....	201
2.13.2	ALTERNATIVE CONFIGURATION 1 TO 3 .....	202
2.13.2.1	CONFIGURATION OPTIONS .....	202
2.13.2.2	GENERATOR / ENGINE .....	202
<b>2.14</b>	<b>EXPANSION</b> .....	<b>203</b>
2.14.1	DSE2130 INPUT MODULES .....	204
2.14.1.1	ANALOGUE INPUT CONFIGURATION .....	205
2.14.1.2	ANALOGUE INPUTS .....	205
2.14.1.3	DIGITAL INPUTS .....	208
2.14.1.3.1	DIGITAL INPUTS .....	209
2.14.1.3.2	ANALOGUE INPUTS .....	210
2.14.2	DSE2131 INPUT MODULES .....	211
2.14.2.1	ANALOGUE INPUT CONFIGURATION .....	212
2.14.2.2	ANALOGUE INPUTS .....	213
2.14.2.3	DIGITAL INPUTS .....	216
2.14.3	DSE2133 INPUT MODULES .....	218
2.14.3.1	ANALOGUE INPUTS .....	219
2.14.4	DSE2152 OUTPUT MODULES .....	222
2.14.4.1	ANALOGUE OUTPUTS .....	223
2.14.4.2	CREATING / EDITING THE OUTPUT CURVE .....	224
2.14.5	DSE2157 RELAY MODULES .....	226
2.14.6	DSE2548 ANNUCIATOR MODULES .....	227
2.14.7	BATTERY CHARGERS .....	229
<b>2.15</b>	<b>ADVANCED</b> .....	<b>231</b>
2.15.1	ADVANCED OPTIONS .....	232
2.15.2	AVR .....	235
2.15.3	RESET ELECTRICAL TRIP .....	238
2.15.4	PLC .....	239
2.15.5	CONFIGURABLE GENCOMM PAGES 166 TO 169 .....	240
2.15.6	CONFIGURABLE EDITOR SCREENS .....	242
<b>3</b>	<b>SCADA</b> .....	<b>243</b>
3.1	GENERATOR IDENTITY .....	244
3.2	MIMIC .....	244
3.3	DIGITAL INPUTS .....	245
3.4	DIGITAL OUTPUTS .....	246
3.5	VIRTUAL LEDES .....	247
3.6	BUS .....	248
3.7	GENERATOR .....	249
3.7.1	FREQUENCY, VOLTAGES AND CURRENT .....	249
3.7.2	POWER .....	250
3.7.3	MULTI-SET .....	251
3.7.4	GOVERNOR / AVR INTERFACE .....	252
3.7.4.1	SW1 .....	252
3.7.4.2	SW2 .....	253
3.7.4.3	SETTINGS .....	253
3.7.4.4	SUMMARY .....	253
3.7.5	SYNC .....	254
3.7.5.1	ANALOGUE .....	254
3.7.5.1.1	ADJUSTING GAIN (P), STABILITY (I) AND DERIVATIVE (D) .....	258
3.7.5.2	RELAY .....	260
3.7.6	LOAD LEVELS .....	262
3.7.7	DROOP .....	265

3.7.8	DE-RATE.....	266
<b>3.8</b>	<b>ENGINE.....</b>	<b>267</b>
3.8.1	FUEL USE AND EFFICIENCY.....	267
<b>3.9</b>	<b>FLEXIBLE SENSORS.....</b>	<b>268</b>
<b>3.10</b>	<b>CONFIGURABLE CAN INSTRUMENTATION.....</b>	<b>269</b>
<b>3.11</b>	<b>ALARMS.....</b>	<b>270</b>
<b>3.12</b>	<b>ENGINE ALARMS.....</b>	<b>271</b>
3.12.1	CURRENT ENGINE ALARMS.....	271
3.12.2	PREVIOUS ENGINE ALARMS.....	271
<b>3.13</b>	<b>STATUS.....</b>	<b>272</b>
<b>3.14</b>	<b>EVENT LOG.....</b>	<b>273</b>
<b>3.15</b>	<b>ENHANCED CANBUS.....</b>	<b>274</b>
<b>3.16</b>	<b>REMOTE CONTROL.....</b>	<b>274</b>
<b>3.17</b>	<b>MAINTENANCE.....</b>	<b>275</b>
3.17.1	RECALIBRATE TRANSDUCERS.....	276
3.17.2	EXPANSION CALIBRATION.....	277
3.17.3	HOURS RUN AND NUMBER OF STARTS.....	277
3.17.4	TIME.....	278
3.17.5	ACCUMULATED INSTRUMENTATION.....	279
3.17.6	ACCUMULATED FUEL USE.....	280
3.17.7	MAINTENANCE ALARM RESET.....	281
3.17.8	ELECTRONIC ENGINE CONTROLS.....	282
3.17.9	MODULE PIN.....	283
<b>3.18</b>	<b>COMMUNICATIONS INFORMATION.....</b>	<b>284</b>
<b>3.19</b>	<b>DATA LOG.....</b>	<b>285</b>
3.19.1	DATA LOG STATUS.....	286
<b>3.20</b>	<b>AVR.....</b>	<b>287</b>
3.20.1	FREQUENCY, VOLTAGES AND CURRENT.....	287
3.20.2	DIAGNOSTICS.....	288
3.20.3	STATUS.....	288
3.20.4	CONTROL.....	289
3.20.5	AVR ALARMS.....	289
<b>3.21</b>	<b>PLC.....</b>	<b>290</b>
3.21.1	PLC LOGIC.....	290
3.21.2	PLC STORES.....	291
<b>3.22</b>	<b>EXPANSION.....</b>	<b>292</b>
<b>4</b>	<b>ALARM TYPES.....</b>	<b>293</b>
<b>5</b>	<b>ALARM ARMING.....</b>	<b>294</b>
5.1	NEVER.....	295
5.2	ALWAYS.....	295
5.3	WHEN STATIONARY.....	295
5.4	FROM STARTING.....	295
5.5	OVERSHOOT.....	295
5.6	FROM SAFETY ON.....	296
5.7	FROM BREAKER CLOSED.....	296
5.8	FROM MAINS PARALLEL.....	296

## 1 INTRODUCTION

This document details the use of the *DSE Configuration Suite PC Software* with the DSE8610 MKII module, which is part of the DSE Genset® range of products.

The manual forms part of the product and should be kept for the entire life of the product. If the product is passed or supplied to another party, ensure that this document is passed to them for reference purposes.

This is not a *controlled document*. DSE do not automatically inform on updates. Any future updates of this document are included on the DSE website at [www.deepseaelectronics.com](http://www.deepseaelectronics.com)



The *DSE Configuration Suite PC Software* allows the DSE8610 MKII module to be connected to a PC via USB A to USB B cable (USB printer cable). Once connected, the software allows easy, controlled access to various operating parameters within the module which can then be viewed and edited as required.

The *DSE Configuration Suite PC Software* must only be used by competent, qualified personnel, as changes to the operation of the module may have safety implications on the panel / generating set to which it is fitted. Access to critical operational sequences and settings for use by qualified engineers, may be barred by a security code set by the generator provider.

The information contained in this manual must be read in conjunction with the information contained in the appropriate module documentation. This manual only details which settings are available and how they may be used. Separate manuals deal with the operation of the individual module and its ancillaries, refer to section entitled *Bibliography* elsewhere in this document for further information.

## 1.1 CLARIFICATION OF NOTATION

Clarification of notation used within this publication.

 <b>NOTE:</b>	Highlights an essential element of a procedure to ensure correctness.
 <b>CAUTION!</b>	Indicates a procedure or practice, which, if not strictly observed, could result in damage or destruction of equipment.
 <b>WARNING!</b>	Indicates a procedure or practice, which could result in injury to personnel or loss of life if not followed correctly.

## 1.2 GLOSSARY OF TERMS

Term	Description
DSE8000 MKII, DSE8xxx MKII	All modules in the DSE8xxx MKII range.
DSE8600 MKII, DSE86xx MKII	All modules in the DSE86xx MKII range.
DSE8610 MKII	DSE8610 MKII module/controller
DSE8x10	DSE8610, DSE8610 MKII, DSE8710, DSE8810 and DSE8910 module/controller
DSE8x60	DSE8660, DSE8660 MKII, DSE8760 and DSE8860 module/controller
DSE8x80	DSE8680 module/controller
CAN	Controller Area Network Vehicle standard to allow digital devices to communicate to one another.
CDMA	Code Division Multiple Access. Cell phone access used in small number of areas including parts of the USA and Australia.
CT	Current Transformer An electrical device that takes a large AC current and scales it down by a fixed ratio to a smaller current.
BMS	Building Management System A digital/computer based control system for a building's infrastructure.
DEF	Diesel Exhaust Fluid (AdBlue) A liquid used as a consumable in the SCR process to lower nitric oxide and nitrogen dioxide concentration in engine exhaust emissions.
DM1	Diagnostic Message 1 A DTC that is currently active on the engine ECU.
DM2	Diagnostic Message 2 A DTC that was previously active on the engine ECU and has been stored in the ECU's internal memory.
DPF	Diesel Particulate Filter A filter fitted to the exhaust of an engine to remove diesel particulate matter or soot from the exhaust gas.
DPTC	Diesel Particulate Temperature Controlled Filter A filter fitted to the exhaust of an engine to remove diesel particulate matter or soot from the exhaust gas which is temperature controlled.
DTC	Diagnostic Trouble Code The name for the entire fault code sent by an engine ECU.
ECU/ECM	Engine Control Unit/Management An electronic device that monitors engine parameters and regulates the fuelling.
FMI	Failure Mode Indicator A part of DTC that indicates the type of failure, e.g. high, low, open circuit etc.

Continued over page...

<b>Term</b>	<b>Description</b>
Fuel Tank Bund	An external tank used to collect fuel that may leak or overflow from the fuel tank. This tank may also be integral to the main fuel tank. A level switch is usually located within the Bund to indicate the presence of the leak or overflow condition. May be called Retention Tank in some locales.
GSM	Global System for Mobile communications. Cell phone technology used in most of the World.
HEST	High Exhaust System Temperature Initiates when DPF filter is full in conjunction with an extra fuel injector in the exhaust system to burn off accumulated diesel particulate matter or soot.
HMI	Human Machine Interface A device that provides a control and visualisation interface between a human and a process or machine.
IDMT	Inverse Definite Minimum Time
IEEE	Institute of Electrical and Electronics Engineers
LED	Light Emitting Diode
MSC	Multi-Set Communication
OC	Occurrence Count A part of DTC that indicates the number of times that failure has occurred.
PGN	Parameter Group Number A CANbus address for a set of parameters that relate to the same topic and share the same transmission rate.
PLC	Programmable Logic Controller A programmable digital device used to create logic for a specific purpose.
R.O.C.O.F.	Rate Of Change Of Frequency
SCADA	Supervisory Control And Data Acquisition A system that operates with coded signals over communication channels to provide control and monitoring of remote equipment
SCR	Selective Catalytic Reduction A process that uses DEF with the aid of a catalyst to convert nitric oxide and nitrogen dioxide into nitrogen and water to reduce engine exhaust emission.
SIM	Subscriber Identity Module. The small card supplied by the GSM/CDMA provider that is inserted into the cell phone, GSM modem or DSEGateway device to give GSM/GPRS connection.
SMS	Short Message Service The text messaging service of mobile/cell phones.
SNMP	Simple Network Management Protocol An international standard protocol for managing devices on IP networks.
SPN	Suspect Parameter Number A part of DTC that indicates what the failure is, e.g. oil pressure, coolant temperature, turbo pressure etc.

## 1.3 BIBLIOGRAPHY

This document refers to, and is referred by the following DSE publications which are obtained from the DSE website: [www.deepseaelectronics.com](http://www.deepseaelectronics.com) or by contacting DSE technical support: [support@deepseaelectronics.com](mailto:support@deepseaelectronics.com).

### 1.3.1 INSTALLATION INSTRUCTIONS

Installation instructions are supplied with the product in the box and are intended as a 'quick start' guide only.

DSE Part	Description
053-004	DSE123 Installation Instructions
053-032	DSE2548 LED Expansion Annunciator Installation Instructions
053-033	DSE2130 Input Expansion Installation Instructions
053-034	DSE2157 Output Expansion Installation Instructions
053-049	DSE9xxx Battery Charger Installation Instructions
053-082	DSE8680 Installation Instructions
053-125	DSE2131 Ratio-metric Input Expansion Installation Instructions
053-126	DSE2133 RTD/Thermocouple Input Expansion Installation Instructions
053-134	DSE2152 Ratio-metric Output Expansion Installation Instructions
053-147	DSE9460 & DSE9461 Battery Charger Installation Instructions
053-152	DSE123 Cummins PCC Variant Installation Instructions
053-182	DSE8610 MKII Installation Instructions
053-184	DSE8660 MKII Installation Instructions
053-185	DSE9473 & DSE9483 Battery Charger Installation Instructions
053-233	DSEA108 Installation Instructions
053-245	DSEA109 Installation Instructions
053-248	DSE8920 Installation Instructions

### 1.3.2 MANUALS

Product manuals are obtained from the DSE website: [www.deepseaelectronics.com](http://www.deepseaelectronics.com) or by contacting DSE technical support: [support@deepseaelectronics.com](mailto:support@deepseaelectronics.com).

DSE Part	Description
N/A	DSEGencomm (MODBUS protocol for DSE controllers)
057-003	DSE123 Operator Manual
057-004	Electronic Engines and DSE Wiring Guide
057-045	Guide to Synchronising and Load Sharing Part 1 (Usage of DSE Load Share Controllers in synchronisation / load sharing systems.)
057-046	Guide to Synchronising and Load Sharing Part 2 (Governor & AVR Interfacing)
057-047	Load Share System Design and Commissioning Guide
057-082	DSE2130 Input Expansion Operator Manual
057-083	DSE2157 Output Expansion Operator Manual
057-084	DSE2548 Annunciator Expansion Operator Manual
057-085	DSE9xxx Battery Charger Operator Manual
057-130	DSE8680 Operator Manual
057-131	DSE8680 Configuration Suite PC Software Manual
057-139	DSE2131 Ratio-metric Input Expansion Manual
057-140	DSE2133 RTD/Thermocouple Expansion Manual
057-141	DSE2152 Ratio-metric Output Expansion Manual
057-151	DSE Configuration Suite PC Software Installation & Operation Manual
057-175	PLC Programming Guide For DSE Controllers
057-176	DSE9460 & DSE9461 Battery Charger Operator Manual
057-254	DSE8610 MKII Operators Manual
057-257	DSE8660 MKII Configuration Suite PC Software Manual
057-259	DSE8660 MKII Operator Manual
057-305	DSSE8910 Configuration Suite PC Software Manual
057-310	DSSE8910 Operators Manual
057-312	DSEAssistant PC Software Manual
057-314	Advanced PLC Software Manual

### 1.3.3 TRAINING GUIDES

Training guides are provided as 'hand-out' sheets on specific subjects during training sessions and contain specific information regarding to that subject.

DSE Part	Description
056-001	Four Steps To Synchronising
056-005	Using CTs With DSE Products
056-006	Introduction to Comms
056-010	Over Current Protection
056-011	MSC Link
056-013	Load Demand Scheme
056-018	Negative Phase Sequence
056-019	Earth Fault Protection
056-020	Loss Of Excitation
056-021	Mains Decoupling
056-022	Switchgear Control
056-023	Adding New CAN Files
056-024	GSM Modem
056-026	kVA, kW, kvar and Power Factor
056-029	Smoke Limiting
056-030	Module PIN Codes
056-033	Synchronising Requirements
056-036	DSE Module Expansion
056-043	Sync Process
056-045	PLC as Load Demand Controller
056-047	Out of Sync and Failed To Close
056-051	Sending DSEGencomm Control Keys
056-053	Recommended Modems
056-054	DSE8x10 In Fixed Export
056-055	Alternate Configurations
056-057	SW1 & SW2
056-069	Firmware Update
056-071	DSE8610 Auto Test Manual
056-072	Dead Bus Synchronising
056-075	Adding Language Files
056-076	Reading DSEGencomm Alarms
056-079	Reading DSEGencomm Status
056-080	MODBUS
056-081	Screen Heaters
056-082	Override Gencomm PLC Example
056-084	Synchronising & Loadsharing
056-086	G59
056-089	DSE86xx MKI to DSE86xx MKII Conversion
056-091	Equipotential Earth Bonding
056-092	Best Practices for Wiring Restive Sensors
056-094	MSC Compatibility
056-095	Remote Start Input Functions
056-097	USB Earth Loops and Isolation
056-098	DSE73xx MKII, DSE74xx MKII, DSE86xx MKII Application Guide for John Deere Tier 4 Final Engines
056-099	Digital Output to Digital Input Connection
056-118	Configurable CAN
056-123	Simulation Injection Testing

### 1.3.4 THIRD PARTY DOCUMENTS

The following third party documents are also referred to:

Reference	Description
ISBN 1-55937-879-4	IEEE Std C37.2-1996 IEEE Standard Electrical Power System Device Function Numbers and Contact Designations. Institute of Electrical and Electronics Engineers Inc
ISBN 0-7506-1147-2	Diesel generator handbook. L.L.J. Mahon
ISBN 0-9625949-3-8	On-Site Power Generation. EGSA Education Committee.

## 1.4 INSTALLATION AND USING THE DSE CONFIGURATION SUITE SOFTWARE

For information in regards to installing and using the *DSE Configuration Suite PC Software*, refer to DSE publication: **057-151 DSE Configuration Suite PC Software Installation & Operation Manual** which is found on the DSE website: [www.deepseaelectronics.com](http://www.deepseaelectronics.com)

## 2 EDITING THE CONFIGURATION

The software is broken down into separate sections to provide simple navigation whilst editing the module's configuration to suit a particular application.

### 2.1 SCREEN LAYOUT

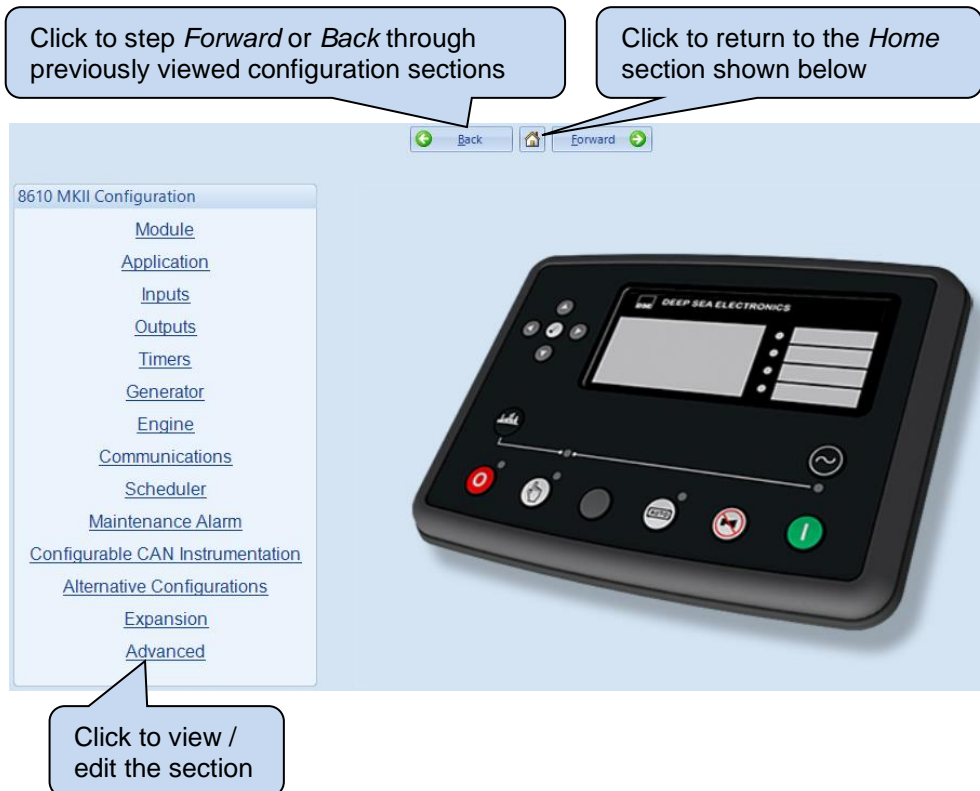
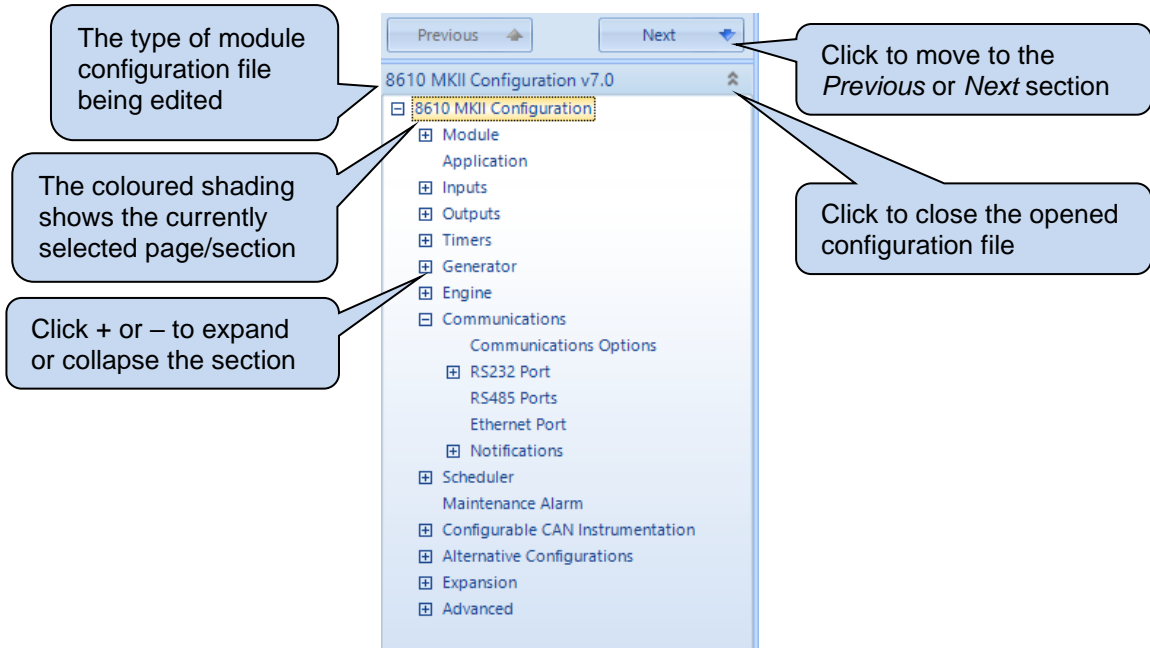

## 2.2 MODULE

The *Module* section allows the user to edit options related to the module itself and is subdivided into smaller sections.

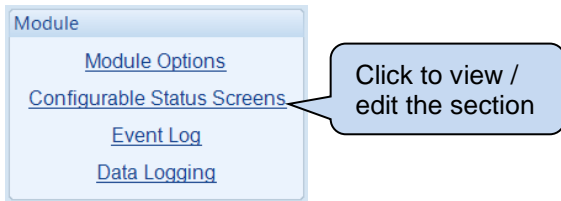

### 2.2.1 MODULE OPTIONS

#### Description

The screenshot shows a 'Description' window with four numbered input boxes (1, 2, 3, 4) for entering text.

Parameter	Description
Description	Four free entry boxes to allow the user to give the configuration file a description. Typically used to enter the job number, customer name, engine information etc.  This text is not shown on the module's display and is only seen in the configuration file.



#### LED Indicators

The screenshot shows the 'LED Indicators' configuration window. It has four rows, each with a number (1-4), a dropdown menu for the function (Digital Input A, Remote Start Over MSC, Common Alarm, Panel Locked), a dropdown menu for polarity (Lit), and a text input field for 'Insert Card Text'. There are 'Text Insert' and 'Logo Insert' buttons at the bottom.



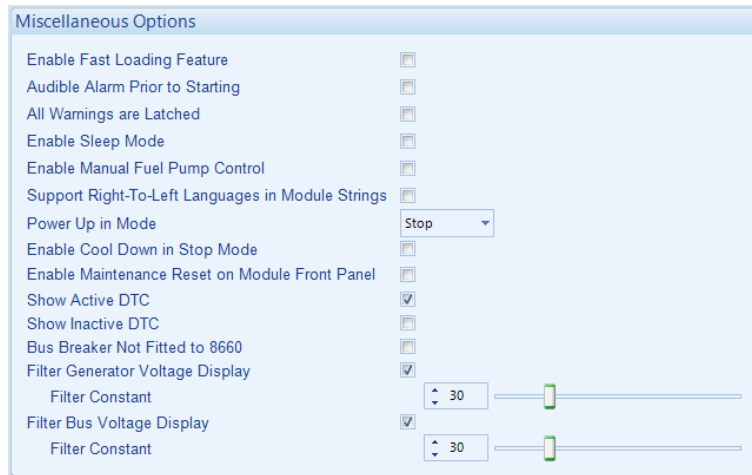





Parameter	Description
Function	Allows the user to assign an output source to an LED indicator which are to the right of the module's LCD. For details of possible selections, see section entitled <i>Output Sources</i> elsewhere in this document.
Polarity	<b>Lit:</b> When the output source is true, the LCD indicator activates. <b>Unlit:</b> When the output source is true, the LCD indicator de-activates.
Insert Card Text	Enter custom text to print on the text insert for the LEDs.
Text Insert	Allows the user to print the custom text insert cards for the LEDs.
Logo Insert	Allow the user to choose and print an image for the logo insert above the LCD.

**Miscellaneous Options**







Parameter	Description
Enable Fast Loading	<p><b>NOTE:</b> Enabling Fast Loading is only recommended where steps have been taken to ensure rapid start up of the engine is possible. (For example when fitted with engine heaters, electronic governors etc.)</p> <p><input type="checkbox"/> = The <i>Fast Loading</i> is disabled. The module observes the <i>Safety on Delay</i> timer in full to allow the generator time to reach operating <i>Oil Pressure, Coolant Temperature, Engine Speed, Loading Voltage and Loading Frequency</i>.</p> <p><input checked="" type="checkbox"/> = The <i>Fast Loading</i> is enabled. The module terminates the <i>Safety on Delay</i> timer once the generator has attained the <i>Loading Voltage and Loading Frequency</i>. This feature is useful if the generator is to be used in critical application as it allows it to start and go on load in the shortest possible time.</p>
Audible Alarm Prior to Starting	<p><input type="checkbox"/> = The <i>Audible Alarm Prior to Starting</i> is disabled.</p> <p><input checked="" type="checkbox"/> = The <i>Audible Alarm Prior to Starting</i> is enabled. The module gives an audible warning during the <i>Pre-Heat Timer</i> to indicate the generator is about to start.</p>
All Warnings Are Latched	<p><input type="checkbox"/> = The <i>All Warnings Are Latched</i> is disabled. The module automatically resets the warning and pre-alarms once the triggering condition has been cleared.</p> <p><input checked="" type="checkbox"/> = The <i>All Warnings Are Latched</i> is enabled. The module does not automatically reset the warning and pre-alarms. Resetting the alarm is performed by either activating a digital input configured for <i>Alarm Reset</i> or, pressing the <b>Stop/Reset Mode</b>  button once the triggering condition has been cleared.</p>
Enable Sleep Mode	<p><input type="checkbox"/> = The <i>Sleep Mode</i> is disabled.</p> <p><input checked="" type="checkbox"/> = The <i>Sleep Mode</i> is enabled. The module goes into a low current mode when it is left in the <b>Stop/Reset Mode</b>  for the duration of the <i>Sleep Timer</i>, if the communication ports or data logging facility are not active. During the <i>Sleep Mode</i> the module effectively powers down and its display turns off. Press any button on the module's fascia to take it out of <i>Sleep Mode</i>.</p>

Parameter descriptions are continued overleaf...



Parameter	Description
Enable Manual Fuel Pump Control	<p><b>⚠ CAUTION!</b> It is possible to overfill the fuel tank when using the Manual Fuel Pump Control feature. Care must be taken to ensure the correct volume of fuel is transferred.</p> <p><b>⚠ NOTE:</b> Manual Fuel Pump Control is only available when a fuel level sensor is configured.</p> <p><input type="checkbox"/> = The <i>Manual Fuel Pump Control</i> is disabled.  <input checked="" type="checkbox"/> = The <i>Manual Fuel Pump Control</i> is enabled. To manually control the fuel pump, press the <b>Tick</b>  button when viewing the <i>Fuel Level</i> instrument on the module's display.</p>
Support Right-To-Left Languages in Module Strings	<p><input type="checkbox"/> = The <i>Support Right-To-Left Languages in Module Strings</i> is disabled. The module displays user configured strings in the order left to right.  <input checked="" type="checkbox"/> = The <i>Support Right-To-Left Languages in Module Strings</i> is enabled. The module displays user configured strings in the order right to left.</p>
Power Up in Mode	<p>Select the mode which the module enters once DC power is applied.</p> <p><b>Auto:</b> The module powers up in the <b>Auto Mode</b> .</p> <p><b>Manual:</b> The module powers up in the <b>Manual Mode</b> .</p> <p><b>Stop:</b> The module powers up in the <b>Stop/Reset Mode</b> .</p>
Enable Cool Down in Stop Mode	<p><input type="checkbox"/> = The <i>Cool Down in Stop Mode</i> is disabled. Pressing the <b>Stop/Reset Mode</b>  button instructs the module to immediately open the generator's switchgear and stop the generator.  <input checked="" type="checkbox"/> = The <i>Cool Down in Stop Mode</i> is disabled. Pressing the <b>Stop/Reset Mode</b>  button instructs the module to immediately open the generator's switchgear and instructs the generator to run for the duration of the <i>Cooling</i> time. Pressing the <b>Stop/Reset Mode</b>  button again results in the generator stopping immediately.</p>
Enable Maintenance Reset on Module Front Panel	<p><input type="checkbox"/> = The <i>Maintenance Reset on Module Front Panel</i> is disabled. The maintenance alarms are only reset using a digital input configured for <i>Maintenance Alarm Reset</i> or the <i>SCADA</i> section of the <i>DSE Configuration Suite</i>.  <input checked="" type="checkbox"/> = The <i>Maintenance Reset on Module Front Panel</i> is enabled. The maintenance alarms are resettable by pressing and holding the <b>Stop/Reset Mode</b>  button when viewing the specific <i>Maintenance</i> instrument on the module's display.</p>
Show Active DTC	<p><b>⚠ NOTE:</b> Show Active DTC is only available when the module is configured to communicate to an engine's ECU/ECM over CANbus.</p> <p><input type="checkbox"/> = The <i>Show Active DTC</i> is disabled. The module does not display DM1 fault codes that are active on the engine ECU/ECM.  <input checked="" type="checkbox"/> = The <i>Show Active DTC</i> is enabled. The module displays DM1 fault codes that are active on the engine ECU/ECM.</p>

Parameter descriptions are continued overleaf...

Parameter	Description
Show Inactive DTC	<p> <b>NOTE: Show Inactive DTC is only available when the module is configured to communicate to an engine's ECU/ECM over CANbus.</b></p> <p><input type="checkbox"/> = The <i>Show Inactive DTC</i> is disabled. The module does not display the historical log of DM2 fault codes from the engine ECU/ECM.  <input checked="" type="checkbox"/> = The <i>Show Inactive DTC</i> is enabled. The module displays the historical log of DM2 fault codes from the engine ECU/ECM.</p>
Bus Breaker Not Fitted to 8660	<p> <b>NOTE: This option must only be enabled when the No Bus Breaker feature is enabled in a DSE8660 MKII module.</b></p> <p> <b>NOTE: This feature is only supported in applications where a single DSE8660 MKII is used.</b></p> <p><input type="checkbox"/> = The <i>Bus Breaker Not Fitted to 8660</i> is disabled. When the DSE8660 MKII opens the common generator bus breaker, the generators continue running in load share mode until they are requested to shutdown.  <input checked="" type="checkbox"/> = The <i>Bus Breaker Not Fitted to 8660</i> is enabled. When the DSE8660 MKII closes the Mains switchgear, it ramps the load off the generators and keeps the generators running in parallel with the Mains producing 0% of kW and kvar until the generators are requested to shutdown.                      Activation of an Electrical Trip alarm on the DSE8660 MKII controller triggers an immediate alarm electrical trip on the DSE8610 MKII for <i>Electrical Trip From 8660</i>.</p>
Filter Generator Voltage Display	<p> <b>NOTE: The generator voltage is only filtered on the module's display and not on the SCADA or any other remote monitoring device.</b></p> <p><input type="checkbox"/> = The <i>Filter Generator Voltage Display</i> is disabled. The rate at which the generator voltage instruments are refreshed is fast in order to display all voltage fluctuations.  <input checked="" type="checkbox"/> = The <i>Filter Generator Voltage Display</i> is enabled. The rate at which the generator voltage instruments are refreshed is configurable based on the <i>Filter Constant</i>. A larger <i>Filter Constant</i> leads to a slower refresh rate, filtering out the fluctuations on the generator voltage instruments.</p>
Filter Bus Voltage Display	<p> <b>NOTE: The Mains voltage is only filtered on the module's display and not on the SCADA or any other remote monitoring device.</b></p> <p><input type="checkbox"/> = The <i>Filter Bus Voltage Display</i> is disabled. The rate at which the bus voltage instruments are refreshed is fast in order to display all voltage fluctuations.  <input checked="" type="checkbox"/> = The <i>Filter Bus Voltage Display</i> is enabled. The rate at which the bus voltage instruments are refreshed is configurable based on the <i>Filter Constant</i>. A larger <i>Filter Constant</i> leads to a slower refresh rate, filtering out the fluctuations on the bus voltage instruments.</p>

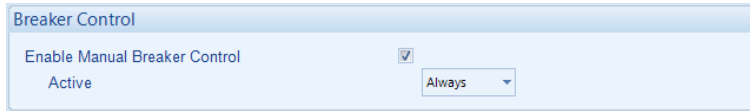
**Breaker Control**





Parameter	Description
<p>Enable Manual Breaker Control</p>	<p><input type="checkbox"/> = The <i>Manual Breaker Control</i> is disabled. When the module is in the <b>Manual Mode</b> , activation of any automatic on load request (such as <i>Remote Start on Load</i>) causes the generator switchgear to close.</p> <p><input checked="" type="checkbox"/> = The <i>Manual Breaker Control</i> is enabled. When the module is in the <b>Manual Mode</b> , only the following load requests cause the generator switchgear to close:</p> <ul style="list-style-type: none"> <li>• Pressing the <b>Transfer to Generator</b>  button.</li> <li>• Activating a digital input configured for <i>Close Generator</i></li> </ul> <p>The <i>Manual Breaker Control</i> is activated:  <b>Always:</b> <i>Manual Breaker Control</i> is always active.  <b>On Input:</b> <i>Manual Breaker Control</i> is only active when a digital input configured for <i>Manual Breaker Mode</i> is active.</p>

## 2.2.2 CONFIGURABLE STATUS SCREENS

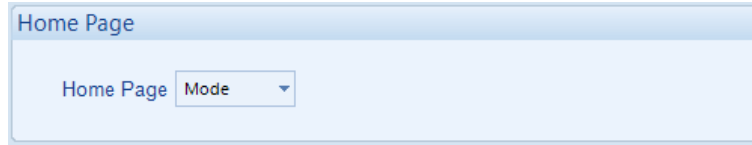
### Home Page



Parameter	Description
Home Page	<p>    <b>Instrumentation:</b> When no <b>Navigation</b> buttons are pressed for the duration of the <i>Page Timer</i>, the module's display scrolls through the <i>Configurable Status Screens</i>. Each of the <i>Configurable Status Screens</i> remains on the display for the duration of the <i>Scroll Timer</i>. The <i>Control Mode</i> page is not displayed automatically but is still accessible by manually pressing the <b>Navigation</b> buttons.         </p> <p>    <b>Mode:</b> When no <b>Navigation</b> buttons are pressed for the duration of the <i>Page Timer</i>, the module's display reverts back to show the <i>Control Mode Page</i>. The <i>Configurable Status Screens</i> are not displayed automatically but is still accessible by manually pressing the <b>Navigation</b> buttons.         </p>

**Displayed Pages**

Displayed Pages

Page 1 <span style="border: 1px solid #ccc; padding: 2px;">Summary Screen ▾</span>	Page 6 <span style="border: 1px solid #ccc; padding: 2px;">Not Used ▾</span>
Page 2 <span style="border: 1px solid #ccc; padding: 2px;">Not Used ▾</span>	Page 7 <span style="border: 1px solid #ccc; padding: 2px;">Not Used ▾</span>
Page 3 <span style="border: 1px solid #ccc; padding: 2px;">Not Used ▾</span>	Page 8 <span style="border: 1px solid #ccc; padding: 2px;">Not Used ▾</span>
Page 4 <span style="border: 1px solid #ccc; padding: 2px;">Not Used ▾</span>	Page 9 <span style="border: 1px solid #ccc; padding: 2px;">Not Used ▾</span>
Page 5 <span style="border: 1px solid #ccc; padding: 2px;">Not Used ▾</span>	Page 10 <span style="border: 1px solid #ccc; padding: 2px;">Not Used ▾</span>

Parameter	Description
Page 1 to 10	Select the instrumentation parameter that is to be displayed for the specific <i>Configurable Status Screen</i> .

**Example**

In the example below, the *Home Page* is configured to *Instrumentation* so will scroll through the *Configurable Status Screens*. Depending on the application, the system designer selects the instrumentation parameters that are most important to constantly show on the module.

Home Page

Home Page Mode ▾

Displayed Pages

Page 1 <span style="border: 1px solid #ccc; padding: 2px;">EPA Icons ▾</span>	Page 6 <span style="border: 1px solid #ccc; padding: 2px;">Not Used ▾</span>
Page 2 <span style="border: 1px solid #ccc; padding: 2px;">Engine Fuel Level ▾</span>	Page 7 <span style="border: 1px solid #ccc; padding: 2px;">Not Used ▾</span>
Page 3 <span style="border: 1px solid #ccc; padding: 2px;">Not Used ▾</span>	Page 8 <span style="border: 1px solid #ccc; padding: 2px;">Not Used ▾</span>
Page 4 <span style="border: 1px solid #ccc; padding: 2px;">Not Used ▾</span>	Page 9 <span style="border: 1px solid #ccc; padding: 2px;">Not Used ▾</span>
Page 5 <span style="border: 1px solid #ccc; padding: 2px;">Not Used ▾</span>	Page 10 <span style="border: 1px solid #ccc; padding: 2px;">Not Used ▾</span>

### 2.2.3 EVENT LOG

#### Display Options

Display Options

Module display  Date and time  
 Engine hours run

Parameter	Description
Module Display	<p><input checked="" type="radio"/> <b>Date and Time</b> = The module displays what the <i>Date and Time</i> was when the <i>Event</i> was logged.</p> <p><input type="radio"/> <b>Engine Hours Run</b> = The module displays what the <i>Engine Hours</i> was when the <i>Event</i> was logged.</p>

#### Logging Options

Logging Options

Log the following events to the event log

Power-Up  Log Fuel Level   
 ECU Shutdown alarms  Log Fuel Level At Rest   
 Engine starts   
 Engine stops

*'Repeat SMS' requires a GSM modem to be configured on the Communications/Basic page*

Shutdown Alarms

Repeat SMS   
 Repeat delay 12h   
 Repeats 2

Electrical Trip Alarms

Repeat SMS   
 Repeat delay 12h   
 Repeats 2

Latched warnings   
 Unlatched warnings

Repeat SMS   
 Repeat delay 12h   
 Repeats 2

Maintenance Alarms

Repeat SMS   
 Repeat delay 12h   
 Repeats 2

Parameter	Description
Power-Up	<p><input type="checkbox"/> = <i>Power-Up</i> events are not logged.</p> <p><input checked="" type="checkbox"/> = <i>Power-Up</i> events are logged when the DC Supply is applied to the module.</p>
ECU Shutdown Alarms	<p><b>NOTE: ECU Alarms are only available when the module is configured to communicate to an engine's ECU/ECM over CANbus.</b></p> <p><input type="checkbox"/> = <i>ECU/ECM Shutdown Alarms</i> are not logged.</p> <p><input checked="" type="checkbox"/> = <i>ECU/ECM Shutdown Alarms</i> are logged when generated by the engine ECU/ECM.</p>

Parameter descriptions are continued overleaf...

**NOTE:** Sending events by SMS is only available when the module is configured to communicate to a supported modem by RS232. Refer to section entitled *RS232 Port* elsewhere in this document for further details.

Parameter	Description
Fuel Level	<p><input type="checkbox"/> = <i>Fuel Monitoring</i> events are not logged when the generator running. Fuel level alarms are still logged if the appropriate alarm category is logged.</p> <p><input checked="" type="checkbox"/> = <i>Fuel Monitoring</i> events are logged when the generator is running.</p>
Fuel Level When at Rest	<p><input type="checkbox"/> = <i>Fuel Monitoring</i> events are not logged when the generator is at rest. Fuel level alarms are still logged if the appropriate alarm category is logged.</p> <p><input checked="" type="checkbox"/> = <i>Fuel Monitoring</i> events are logged when the generator is at rest.</p>
Engine Starts	<p><input type="checkbox"/> = <i>Engine Start</i> events are not logged.</p> <p><input checked="" type="checkbox"/> = <i>Engine Start</i> events are logged when the generator successfully crank disconnects.</p>
Engine Stops	<p><input type="checkbox"/> = <i>Engine Stop</i> events are not logged.</p> <p><input checked="" type="checkbox"/> = <i>Engine Stop</i> events are when the <i>Stopping Timer</i> ceases.</p>
Shutdown Alarms	<p><input type="checkbox"/> = <i>Shutdown Alarms</i> are not logged.</p> <p><input checked="" type="checkbox"/> = <i>Shutdown Alarms</i> are logged when the moment they activate.</p>
Shutdown Alarms Repeat SMS	<p><input type="checkbox"/> = <i>Shutdown Alarms</i> are only sent once via an SMS message.</p> <p><input checked="" type="checkbox"/> = <i>Shutdown Alarms</i> are sent via SMS repeatedly until the <i>Repeats</i> value has been met. The delay between the repeated SMS is set by the <i>Repeats Delay</i> value.</p>
Electrical Trip Alarms	<p><input type="checkbox"/> = <i>Electrical Trip Alarms</i> are not logged.</p> <p><input checked="" type="checkbox"/> = <i>Electrical Trip Alarms</i> are logged when the moment they activate.</p>
Electrical Trip Alarms Repeat SMS	<p><input type="checkbox"/> = <i>Electrical Trip Alarms</i> are only sent once via an SMS message.</p> <p><input checked="" type="checkbox"/> = <i>Electrical Trip Alarms</i> are sent via SMS repeatedly until the <i>Repeats</i> value has been met. The delay between the repeated SMS is set by the <i>Repeats Delay</i> value.</p>
Latched Warnings	<p><input type="checkbox"/> = <i>Latched Warnings Alarms</i> are not logged.</p> <p><input checked="" type="checkbox"/> = <i>Latched Warnings Alarms</i> are logged when the moment they activate.</p>
Unlatched Warnings	<p><input type="checkbox"/> = <i>Unlatched Warnings Alarms</i> are not logged.</p> <p><input checked="" type="checkbox"/> = <i>Unlatched Warnings Alarms</i> are logged when the moment they activate.</p>
Unlatched Warnings Alarms Repeat SMS	<p><input type="checkbox"/> = <i>Unlatched Warnings Alarms</i> are only sent once via an SMS message.</p> <p><input checked="" type="checkbox"/> = <i>Unlatched Warnings Alarms</i> are sent via SMS repeatedly until the <i>Repeats</i> value has been met. The delay between the repeated SMS is set by the <i>Repeats Delay</i> value.</p>
Maintenance Alarms	<p><input type="checkbox"/> = <i>Maintenance Alarms</i> are not logged.</p> <p><input checked="" type="checkbox"/> = <i>Maintenance Alarms</i> are logged when the moment they activate.</p>
Maintenance Alarms Repeat SMS	<p><input type="checkbox"/> = <i>Maintenance Alarms</i> are only sent once via an SMS message.</p> <p><input checked="" type="checkbox"/> = <i>Maintenance Alarms</i> are sent via SMS repeatedly until the <i>Repeats</i> value has been met. The delay between the repeated SMS is set by the <i>Repeats Delay</i> value.</p>

### 2.2.3.1 ENGINE DTC LOGGING

Logging Options (SMS messages will not be sent)

Engine DTC Logging

Parameter	Description
Always	When selected, DTCs are immediately logged upon occurrence
Never	Select to disable Engine DTC logging
Shutdowns and Warnings	When selected, Engine DTCs are logged when an ECU Shutdown or ECU Warning occurs, the timestamp for the DTC in the event log is that of the Shutdown or Warning
Shutdowns Only	When selected, Engine DTCs are logged when an ECU Shutdown occurs, the timestamp for the DTC in the event log is that of the Shutdown

## 2.2.4 DATA LOGGING

The *Data Logging* section is subdivided into smaller sections.

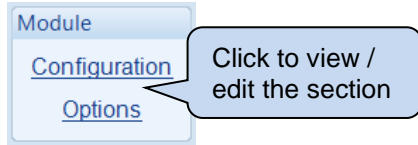

The module has the ability to record up to twenty parameters and is saved as a *Data Log File* to the module's internal memory or an external USB storage device. If 20 parameters were configured to be logged, each with a *Log Interval* of 1 second, the length of each *Data Log File* would be 6 hours and 21 minutes. This time is extendable as the length of each *Data Log File* varies upon the number of selected parameters and their configured *Log Interval*.

The module has the ability to store only one *Data Log File* to its internal memory. The number of *Data Log Files* increases when an external USB storage device is connected to the module's USB Host port. The increased number of *Data Log Files* is dependent upon the size of the USB storage device connected. When using the maximum size USB storage device of 16 GB, the number of *Data Log Files* is increased to 8200. This results in a total *Data Log* length of 46 weeks, 2 days, 6 hours and 24 minutes (assuming 20 parameters were configured to be logged, each with a *Log Interval* of 1 second).

The *Data Logging* is viewed using the *Data Log Viewer* application, which is accessed from the DSE Configuration Suite PC Software under the *Tools* menu.

2.2.4.1 CONFIGURATION

**Data Logging**

	Logged data	Log Interval
1	DC Power On	1 minute
2	Generator Total Power	1 second
3	Generator Current L1	1 second
4	Generator Volts (L1-N)	1 second
5	<Not Used>	1 second
6	<Not Used>	1 second
7	<Not Used>	1 second
8	<Not Used>	1 second
9	<Not Used>	1 second
10	<Not Used>	1 second
11	<Not Used>	1 second
12	<Not Used>	1 second
13	<Not Used>	1 second
14	<Not Used>	1 second
15	<Not Used>	1 second
16	<Not Used>	1 second
17	<Not Used>	1 second
18	<Not Used>	1 second
19	<Not Used>	1 second
20	<Not Used>	1 second

Parameter	Description
Logged Data	Select the instrument required to be logged
Log Interval	Select the logging interval of the data

2.2.4.2 OPTIONS

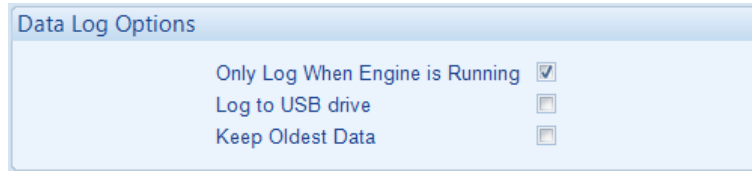

Parameter	Description
Only Log When Engine is Running	<input type="checkbox"/> = The module logs data regardless of engine running state. <input checked="" type="checkbox"/> = The module only logs data when the engine is running.
Log to USB Drive	<input type="checkbox"/> = The module logs data to the modules internal memory. <input checked="" type="checkbox"/> = The module logs data to an external USB memory device connect to the USB host socket on the module.
Keep Oldest Data	<input type="checkbox"/> = When the logging memory is full, the module overwrites the oldest data first with the new data. <input checked="" type="checkbox"/> = When the logging memory is full, the module stops recording new data.

## 2.3 APPLICATION

### ECU (ECM Options)

ECU (ECM) Options

Engine Type Cummins QST

Enhanced J1939

Alternative Engine Speed

Modbus Engine Comms Port RS485 Port

**NOTE:** For further details and instructions on ECU (ECM) options and connections, refer to DSE Publication: *057-004 Electronic Engines and DSE Controllers* which are found on our website: [www.deepseaelectronics.com](http://www.deepseaelectronics.com)

Parameter	Description
Engine Type	<p>Select the appropriate engine type</p> <p><b>Conventional Diesel:</b> Select this for a traditional (non-electronic) engine, either Energise to Run or Energise to Stop.</p> <p><b>Conventional Gas:</b> Select this for a traditional (non-electronic) engine and require Gas engine functionality. This enables control of configurable outputs for <i>Gas Choke and Gas Ignition</i> and instructs the module to follow the gas engine timers.</p> <p><b>Other Engines:</b> The list of supported CAN (or MODBUS) engines is constantly updated, check the DSE website at <a href="http://www.deepseaelectronics.com">www.deepseaelectronics.com</a> for the latest version of Configuration Suite software.</p>
Enhanced J1939	<p><input type="checkbox"/> = The module reads 'Basic' instrumentation from the engine ECU (ECM) and display (where supported by the engine) :</p> <ul style="list-style-type: none"> <li>• Engine Speed</li> <li>• Oil Pressure</li> <li>• Engine Coolant Temperature</li> <li>• Hours Run</li> </ul> <p><input checked="" type="checkbox"/> = The module reads and display an 'Enhanced' instrumentation list (where supported by the engine) :</p> <ul style="list-style-type: none"> <li>• Engine Speed</li> <li>• Engine Speed Biasing (Subject to <i>ECM Speed Control</i> setting)</li> <li>• Oil Pressure</li> <li>• Engine Coolant Temperature</li> <li>• Hours Run</li> <li>• Engine Oil Temperature</li> <li>• Exhaust Temperature</li> <li>• Fuel Pressure</li> <li>• Total Fuel used</li> <li>• Fuel Consumption</li> <li>• Inlet Manifold Temperature</li> <li>• Coolant Pressure</li> <li>• Turbo Pressure</li> <li>• And more...</li> </ul> <p>Where an instrument is not supported by the engine ECU (ECM), the instrument is not displayed. DSE Reserve the right to change these lists in keeping with our policy of continual development.</p>

Parameter descriptions are continued overleaf...

Parameter	Description
Alternative Engine Speed	<input type="checkbox"/> = The engine is instructed to run at its <i>Nominal Speed</i> as configured by the Engine Manufacturer. <input checked="" type="checkbox"/> = The engine is instructed to run at its <i>Alternative Speed</i> as configured by the Engine Manufacturer.
MODBUS Engine Comms Port	<p><b>RS485 Port:</b> The modules RS485 port is used to communicate to the engine (when a Modbus engine type is selected).</p> <p><b>DSENet Port:</b> The modules DSENet port is used to communicate to the engine (when a Modbus engine type is selected. This 'frees' the RS485 port in case connection to BMS or other RS485 compatible equipment is required.</p>

**Auto Voltage Sensing**

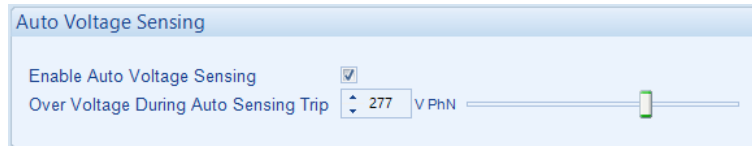

Option	Description
Enable Auto Voltage Sensing	<input type="checkbox"/> = The module uses the selected <i>Main Configuration</i> or <i>Alternative Configuration</i> . <input checked="" type="checkbox"/> = <i>Auto Voltage Sensing</i> is enabled. When the generator is started, the module monitors the generator voltage. Depending on the voltage level and <i>AC System</i> detected, the module automatically selects between the <i>Mains Configuration</i> and <i>Alternative Configuration</i> . This is useful for hire generators where the <i>AC System</i> is selectable as no digital input signals are required to be given to the DSE module.

**Rear Mount Option**

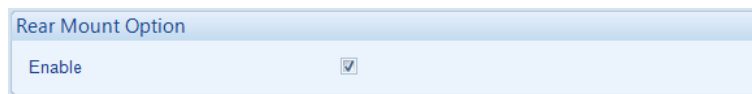

Option	Description
Rear Mount Option Enable	<p><b>NOTE: For further details on supported displays when the DSE module is mounted into the rear of the panel, contact DSE Technical Support <a href="mailto:support@deepseaelectronics.com">support@deepseaelectronics.com</a>.</b></p> <p><input type="checkbox"/> = The module's display, fascia buttons and LEDs are enabled and is to be mounted on the fascia of the panel.  <input checked="" type="checkbox"/> = The <i>Rear Mount Option</i> is enabled. The module's display, fascia buttons and LEDs are disabled to allow the module to be mount in the rear of a panel using the <i>DSE Rear Mount Panel Bracket</i>; Part Number 020-1044. A remote display is required to provide local monitoring and control of the generator.</p>

## 2.4 INPUTS

The *Inputs* section is subdivided into smaller sections. Select the required section with the mouse.

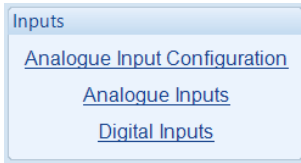

### 2.4.1 ANALOGUE INPUT CONFIGURATION

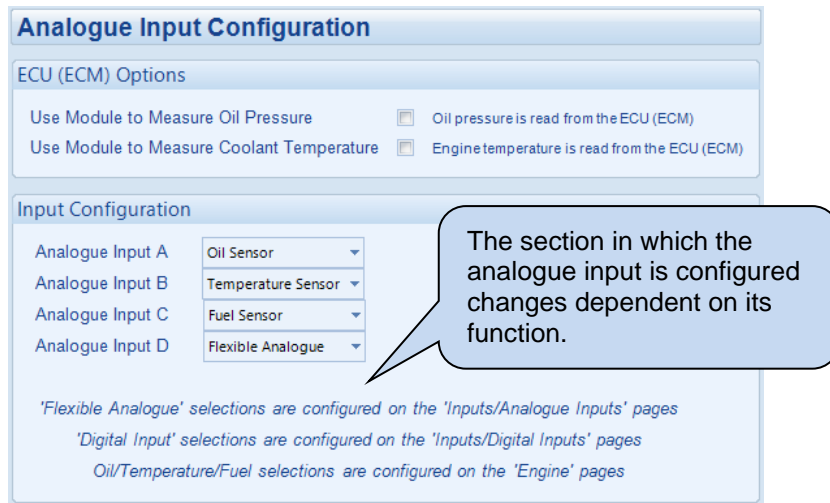

#### ECU (ECM) Options

Parameter	Description
Use Module To Measure Oil Pressure	(Available only when the module is configured for connection to a CAN engine.) <input type="checkbox"/> = The measurements are taken from the ECU (ECM). <input checked="" type="checkbox"/> = The module ignores the CAN measurement and uses the analogue sensor input.
Use Module To Measure Coolant Temperature	(Available only when the module is configured for connection to a CAN engine.) <input type="checkbox"/> = The measurements are taken from the ECU. <input checked="" type="checkbox"/> = The module ignores the CAN measurement and uses the analogue sensor input.

Parameter descriptions are continued overleaf...

**Input Configuration**

<b>Parameter</b>	<b>Description</b>
Analogue Input A	Select what the analogue input is to be used for: <b>Not Used:</b> The analogue input is disabled <b>Digital Input:</b> Configured on the <i>Inputs/Digital Inputs</i> pages <b>Flexible Analogue:</b> Configured on the <i>Inputs/Analogue Inputs</i> pages <b>Oil Sensor:</b> Configured on the <i>Engine</i> pages
Analogue Input B	Select what the analogue input is to be used for: <b>Not Used:</b> The analogue input is disabled <b>Digital Input:</b> Configured on the <i>Inputs/Digital Inputs</i> pages <b>Flexible Analogue:</b> Configured on the <i>Inputs/Analogue Inputs</i> pages <b>Temperature Sensor:</b> Configured on the <i>Engine</i> pages
Analogue Input C	Select what the analogue input is to be used for: <b>Not Used:</b> The analogue input is disabled <b>Digital Input:</b> Configured on the <i>Inputs/Digital Inputs</i> pages <b>Flexible Analogue:</b> Configured on the <i>Inputs/Analogue Inputs</i> pages <b>Fuel Sensor:</b> Configured on the <i>Engine</i> pages
Analogue Input D	Select what the analogue input is to be used for: <b>Not Used:</b> The analogue input is disabled <b>Digital Input:</b> Configured on the <i>Inputs/Digital Inputs</i> pages <b>Flexible Analogue:</b> Configured on the <i>Inputs/Analogue Inputs</i> pages

## 2.4.2 ANALOGUE INPUTS

**NOTE:** An analogue input is only configurable as a flexible sensor if it has been configured as *Flexible Analogue*, refer to section entitled *Analogue Input Configuration* elsewhere in this document for further details.

### Sensor Description

Sensor Description

Sensor Name

Parameter	Description
Sensor Name	Enter the <i>Sensor Name</i> , this text is shown on the module display when viewing the instrument.

### Input Type

Input Type

VDO Ohm range (10-180)

Parameter	Description
Input Type	<p>Select the sensor type and curve from a pre-defined list or create a user-defined curve.</p> <p>Available sensor types:  <b>Current:</b> for sensors with maximum range of 0 mA to 20 mA  <b>Resistive:</b> for sensors with maximum range of 0 <math>\Omega</math> to 480 <math>\Omega</math>  <b>Voltage:</b> for sensors with maximum range of 0 V to 10 V</p> <p>Available parameters to be measured:  <b>Pressure:</b> The input is configured as a pressure sensor  <b>Percentage:</b> The input is configured as a percentage sensor  <b>Temperature:</b> The input is configured as a temperature sensor</p>

**Sensor Alarms**

Parameter	Description
Alarm Arming	<p><b>▲ NOTE: For details of these, see the section entitled <i>Alarm Arming</i> elsewhere in this document.</b></p> <p>Select when the alarm generated by the analogue input becomes active:  <b><i>Always</i></b>  <b><i>From Safety On</i></b>  <b><i>From Starting</i></b></p>
Low Alarm Enable	<p><input type="checkbox"/> = The Alarm is disabled.  <input checked="" type="checkbox"/> = The <i>Low Alarm</i> activates when the measured quantity drops below the <i>Low Alarm</i> setting.</p>
Low Alarm Action	<p><b>▲ NOTE: For details of these, see the section entitled <i>Alarm Types</i> elsewhere in this document.</b></p> <p>Select the type of alarm required from the list:  <b><i>Electrical Trip</i></b>  <b><i>Shutdown</i></b></p>
Low Pre-Alarm Enable	<p><input type="checkbox"/> = The Pre-Alarm is disabled.  <input checked="" type="checkbox"/> = The <i>Low Pre-Alarm</i> is active when the measured quantity drops below the <i>Low Pre-Alarm Trip</i> setting. The <i>Low Pre-Alarm</i> is automatically reset when the measured quantity rises above the configured <i>Low Pre-Alarm Return</i> level.</p>
Low Alarm String	<p>The text that is displayed on the module's LCD when the <i>Low Alarm</i> or <i>Low Pre-Alarm</i> activates.</p>

Parameter descriptions are continued overleaf...

Editing the Configuration

Parameter	Description
High Pre-Alarm Enable	<input type="checkbox"/> = The Pre-Alarm is disabled. <input checked="" type="checkbox"/> = The <i>High Pre-Alarm</i> is active when the measured quantity rises above the <i>High Pre-Alarm Trip</i> setting. The <i>High Pre-Alarm</i> is automatically reset when the measured quantity falls below the configured <i>High Pre-Alarm Return</i> level.
High Alarm Enable	<input type="checkbox"/> = The Alarm is disabled. <input checked="" type="checkbox"/> = The <i>High Alarm</i> is active when the measured quantity rises above the <i>High Alarm</i> setting.
High Alarm Action	<div style="border: 3px double black; padding: 5px;"> <p> <b>NOTE: For details of these, see the section entitled <i>Alarm Types</i> elsewhere in this document.</b></p> </div> <p>Select the type of alarm required from the list:  <b><i>Electrical Trip</i></b>  <b><i>Shutdown</i></b></p>
High Alarm String	The text that is displayed on the module's LCD when the <i>High Alarm</i> or <i>High Pre-Alarm</i> activates.

### 2.4.2.1 CREATING / EDITING THE SENSOR CURVE

While the *DSE Configuration Suite* holds sensor specifications for the most commonly used resistive sensors, occasionally it is required that the module be connected to a sensor not listed by the *DSE Configuration Suite*. To aid this process, a sensor curve editor is provided.

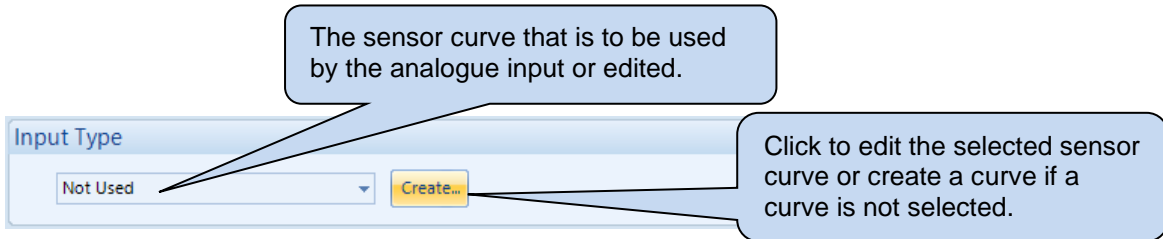

When creating a new sensor curve the measurement quantity and measured parameter are required.

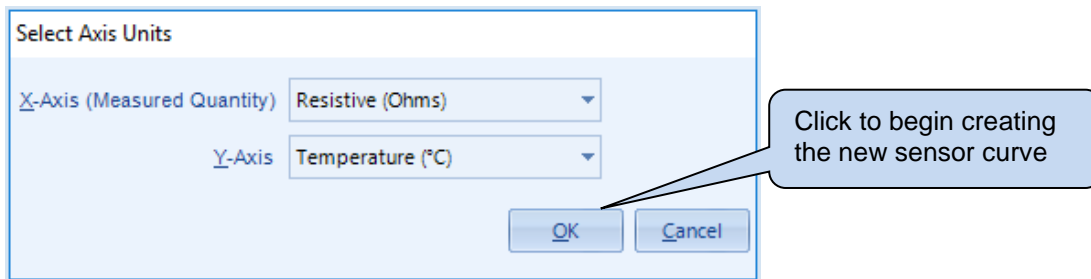

Parameter	Description
X-Axis (Measured Quantity)	Select the electrical quantity that the sensor outputs. <b>Current (mA)</b> : For sensors that output current within a range 0 mA to 20 mA <b>Voltage (Volt)</b> : For sensors that output voltage within a range of 0 V to 10 V <b>Resistive (Ohms)</b> : For sensors that output a resistance within a range 0 Ω to 480 Ω
Y-Axis	Select the parameter that is being monitored by the sensor. <b>Temperature (°C)</b> : For sensors that measure temperature. <b>Pressure (Bar)</b> : For sensors that measure pressure. <b>Percentage (%)</b> : For sensors that measure percentage.

Sensor curve creation / editor descriptions are continued overleaf...

## Editing the Configuration

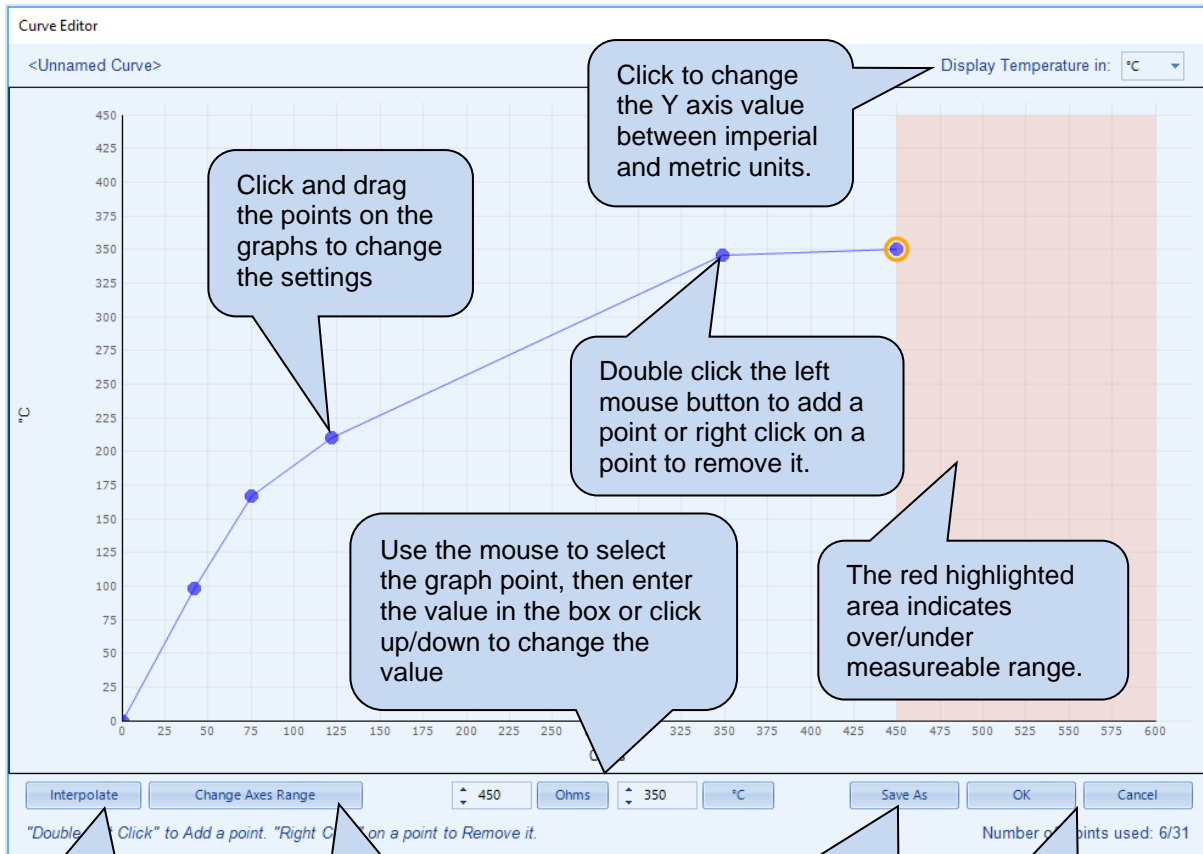

Click *Interpolate* then select two points as prompted to draw a straight line between

Click to change the range of the X and Y Axes of the graph and the level of open circuit

Click **SAVE AS**, a prompt to name the curve...

New Curve Name

Enter a name for the new curve

OK Cancel

Click OK to save the curve.

**Any saved curves become selectable in the *Input Type* selection list.**

Click OK to accept the changes or CANCEL to ignore and lose the

**Hint:** Deleting, renaming or editing custom sensor curves that have been added is performed in the main menu, select *Tools | Curve Manager*.

### 2.4.3 DIGITAL INPUTS

The *Digital Inputs* section is subdivided into smaller sections. Select the required section with the mouse.

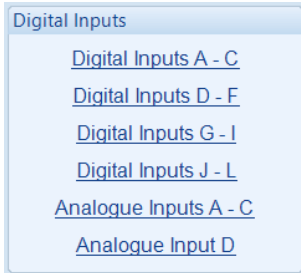

#### 2.4.3.1 DIGITAL INPUTS

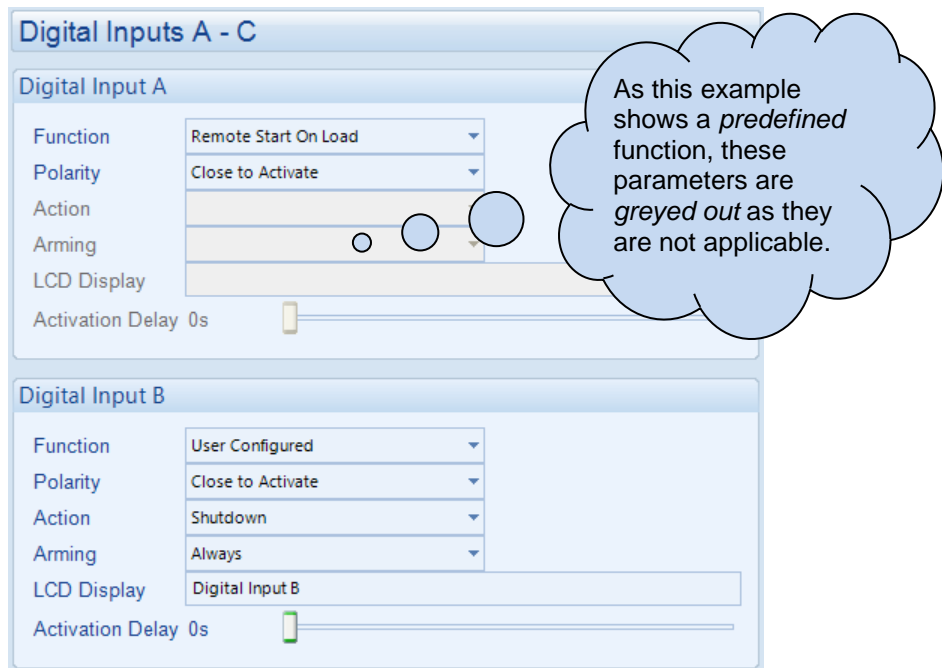

Parameter	Description
Function	Select the input function to activate when the relevant terminal is energised. See section entitled <i>Input Functions</i> for details of all available functions
Polarity	Select the digital input polarity: <b>Close to Activate:</b> the input function is activated when the relevant terminal is connected. <b>Open to Activate:</b> the input function is activated when the relevant terminal is disconnected.
Action	<div style="border: 2px solid black; padding: 5px; margin-bottom: 5px;"> <p><b>⚠ NOTE:</b> For details of these, see the section entitled <i>Alarm Types</i> elsewhere in this document.</p> </div> <p>Select the type of alarm required from the list:  <b>Electrical Trip</b>  <b>Indication</b>  <b>Shutdown</b>  <b>Warning</b></p>

Parameter descriptions are continued overleaf...

Parameter	Description
Arming	<div style="border: 1px solid black; padding: 2px; margin-bottom: 5px;">  <b>NOTE: For details of these, see the section entitled <i>Alarm Arming</i> elsewhere in this document.</b> </div> <p>Select when the alarm generated by the input becomes active:  <b><i>Active from Mains Parallel</i></b>  <b><i>Always</i></b>  <b><i>From Safety On</i></b>  <b><i>From Starting</i></b>  <b><i>Never</i></b></p>
LCD Display	The text that is displayed on the module's LCD when the input activates and generates an alarm.
Activation Delay	This is used to give a delay on acceptance of the input. Useful for liquid level switches or to mask short term operations of the external switch device.

### 2.4.3.2 ANALOGUE INPUTS

**NOTE:** An analogue input is only configurable as a digital input if it has been configured as *Digital Input*, refer to section entitled *Analogue Input Configuration* elsewhere in this document for further details.

#### Analogue Inputs

##### Analogue Input A (Digital)

Function	User Configured
Polarity	Close to Activate
Action	Warning
Arming	Always
LCD Display	Analogue Input A (Digital)
Activation Delay 0s	<input type="range"/>

##### Analogue Input B (Digital)



The Analogue Input is not configured as a Digital Input  
To reconfigure, use the 'Analogue Input Configuration' page

Parameter	Description
Function	Select the input function to activate when the relevant terminal is energised. See section entitled <i>Input Functions</i> for details of all available functions
Polarity	Select the digital input polarity: <b>Close to Activate:</b> the input function is activated when the relevant terminal is connected. <b>Open to Activate:</b> the input function is activated when the relevant terminal is disconnected.
Action	<div style="border: 1px solid black; padding: 5px; margin-bottom: 5px;"> <p><b>NOTE:</b> For details of these, see the section entitled <i>Alarm Types</i> elsewhere in this document.</p> </div> <p>Select the type of alarm required from the list: <b>Electrical Trip Indication</b> <b>Shutdown</b> <b>Warning</b></p>
Arming	<div style="border: 1px solid black; padding: 5px; margin-bottom: 5px;"> <p><b>NOTE:</b> For details of these, see the section entitled <i>Alarm Arming</i> elsewhere in this document.</p> </div> <p>Select when the alarm generated by the input becomes active: <b>Active from Mains Parallel</b> <b>Always</b> <b>From Safety On</b> <b>From Starting</b> <b>Never</b></p>
LCD Display	The text that is displayed on the module's LCD when the input activates and generates an alarm.
Activation Delay	This is used to give a delay on acceptance of the input. Useful for liquid level switches or to mask short term operations of the external switch device.

### 2.4.3.3 INPUT FUNCTIONS

Where a digital input is NOT configured as “user configured”, a selection is made from a list of predefined functions. The selections are as follows:

Under the scope of IEEE 37.2, function numbers are also used to represent functions in microprocessor devices and software programs. Where the DSE input functions are represented by IEEE 37.2, the function number is listed below.

Function	Description
Air Flap Closed Auxiliary IEEE 37.2 - 3 Checking or Interlocking Relay	This input is used to connect to the air flap switch contacts. This gives an immediate shutdown in the event of the air flap being closed. It also prevents the generator from being restarted if the air flap has not been reset following an over-speed shutdown.
Alarm Mute	This input is used to silence the audible alarm from an external source, such as a remote mute switch.
Alarm Reset	This input is used to reset any latched alarms from a remote location. It is also used to clear any latched warnings which may have occurred (if configured) without having to stop the generator.
Alt Config 1, 2 or 3 Select	These inputs are used to instruct the module to follow the relevant <i>alternative</i> configuration settings instead of the <i>main</i> configuration settings.
Alternative Language Select	This input is used to instruct the module to display the alternative Language instead of the default module display language.
Auto Run Inhibit IEEE 37.2 - 3 Checking Or Interlocking Relay	<div style="border: 1px solid black; padding: 5px;">  <b>NOTE: This input does not prevent the generators starting and running in <i>Manual</i> mode.</b> </div> <p>This input is used to provide an over-ride function to prevent the controller from starting and/or running the generator in the event of a remote start and /or scheduled run condition occurring. If this input is active and a remote start signal/scheduled run occurs the module does not give a start command to the generator or stops the generator if it is already running. If this input signal is then removed, the controller operates as if a remote start/scheduled run has occurred, starting and loading the generator. This function is used to give an ‘<b>AND</b>’ function so that a generator is only called to start/run if a remote start request and another condition exists which requires the generator to run. If the ‘Auto Run Inhibit’ signal becomes active while the generator is running, a controlled shutdown sequence begins. If the generator is running in a load demand scheme, this input takes priority and begins the controlled shutdown sequence, causing another generator to start (if available).</p>
Auto Start Inhibit IEEE 37.2 - 3 Checking Or Interlocking Relay	<div style="border: 1px solid black; padding: 5px;">  <b>NOTE: This input does not prevent the generators starting in <i>Manual</i> mode.</b> </div> <p>This input is used to provide an over-ride function to prevent the controller from starting the generator in the event of a remote start/Mains out of limits condition occurring. If this input is active and a remote start signal/Mains failure occurs the module does not give a start command to the generator. If this input signal is then removed, the controller operates as if a remote start/Mains failure has occurred, starting and loading the generator. This function is used to give an ‘<b>AND</b>’ function so that a generator is only called to start if the Mains fails and another condition exists which requires the generator to run. If the ‘Auto start Inhibit’ signal becomes active once more it is ignored until the module has returned the Mains supply on load and shutdown. This input does not prevent starting of the engine in <b>MANUAL</b> mode.</p>

Parameter descriptions are continued overleaf...

Function	Description
Clear Mains Decoupling Alarms	This input is used to reset the module following a Mains Decoupling Alarm (ROCOF, vector shift, Mains Voltage Alarm, Mains Frequency Alarm). The input must switch from inactive to active to reset the trip, it is not to be left permanently active.
Close Generator IEEE 37.2 - 52 AC Circuit Breaker	Closes the Generator load switch when the generator is available. Used to simulate the <i>Close Generator Breaker</i> button externally.
Coolant Temperature Switch IEEE 37.2 – 26 Apparatus Thermal Device	This input is used to give a <i>Coolant Temperature High</i> shutdown from a digital normally open or closed switch. It allows coolant temperature protection.
Disable Protections	The system designer provides this switch (not DSE) so its location varies depending upon manufacturer, however it normally takes the form of a key operated switch to prevent inadvertent activation. Depending upon configuration, a warning alarm is generated when the switch is operated. When active, and the module is suitably configured (see section entitled <i>Advanced Options</i> ) this prevents the engine being stopped upon critical alarm (Sometimes called Battle-Short Mode, War Mode or Run to Destruction)
DPF Auto Regen Inhibit	This input is used to override the ECU (ECM) function and prevent the automatic regeneration of the diesel particulate filter
DPF Force Regeneration	This input is used to override the ECU (ECM) function and activate the regeneration of the diesel particulate filter
DPF Regeneration Interlock	This input is used to stop a manual regeneration from occurring
Droop Enable	This input is used to enable the droop function on a supported ECU/ECM that is fitted to the engine.
Duty Select IEEE 37.2 - 10 Unit sequence switch	This input is used to force the appropriate set to become the duty set when using a load demand scheme. Irrespective of the priority number configured in the module, it will be forced to become the priority set. This allows for manual duty selection, overriding the automatic system normally used by the modules.
EJP1	For the French EJP (Effacement Jours de Pointe) tariff system.  This input is functionally identical to <i>Remote Start Off Load</i> . When this input is active, operation is similar to the 'Remote Start on load' function except that the generator is not instructed to take the load. This function is also used where an engine only run is required e.g. for exercise.
EJP2	For the French EJP (Effacement Jours de Pointe) tariff system.  This input is functionally identical to <i>Remote Start On Load</i> . In auto mode, the module performs the start sequence and transfers load to the generator. In Manual mode, the load is transferred to the generator if the engine is already running, however in manual mode, this input does not generate start/stop requests of the engine.
Enable Power Mode 1 Constant Power (Default)	This input is used to instruct the module to switch to <i>Power Mode 1 Constant Power (Default)</i>
Enable Power Mode 2 Frequency-Power	This input is used to instruct the module to switch to <i>Power Mode 2 Frequency-Power</i>
Enable Power Mode 3 Voltage-Power	This input is used to instruct the module to switch to <i>Power Mode 3 Voltage-Power</i>
Enable Reactive Mode 1 Constant Power Factor	This input is used to instruct the module to switch to <i>Reactive Mode 1 Constant Power Factor</i>
Enable Reactive Mode 2 Voltage-Reactive Power	This input is used to instruct the module to switch to <i>Reactive Mode 2 Voltage-Reactive Power</i>

Parameter descriptions are continued overleaf...

Function	Description
Enable Reactive Mode 3 Power-Power Factor	This input is used to instruct the module to switch to <i>Reactive Mode 3 Power-Power Factor</i>
Enable Reactive Mode 4 Constant Reactive Power (Default)	This input is used to instruct the module to switch to <i>Reactive Mode 4 Constant Reactive Power (Default)</i>
External Panel Lock	<p><b>▲ NOTE: External control sources (i.e. Simulate Start Button) are not affected by the external panel lock input and continue to operate normally.</b></p> <p>This input is used to provide security to the installation. When the External Panel lock input is active, the module does not respond to operation of the Mode select or Start buttons. This allows the module to be placed into a specific mode (such as Auto) and then secured. The operation of the module is not affected and the operator is still able to view the various instrumentation pages etc. (<i>Front panel configuration access is still possible while the system lock is active</i>).</p>
Frequency Droop Enable	<p><b>▲ NOTE: For further details on the <i>Frequency Droop</i> function, refer to the section entitled <i>Load Control</i> elsewhere in this document.</b></p> <p>This input is used to disable the standard isochronous kW load share function and enable the <i>Frequency Droop</i> function within the DSE module.</p>
Fuel Tank Bund Level High	This input is used to provide protection against fuel leakage, where a level switch is fitted to the fuel tank bund. The action for this alarm is configurable under the <i>Engine Protections</i> page in the module configuration.
Generator Closed Auxiliary IEEE 37.2 - 3 Checking or Interlocking Relay	This input is used to provide feedback to allow the module to give true indication of the contactor or circuit breaker switching status. It must be connected to the generator load switching device auxiliary contact.
Generator Load Inhibit IEEE 37.2 - 52 AC Circuit Breaker	<p><b>▲ NOTE: This input only operates to control the generator-switching device if the module load switching logic is attempting to load the generator. It does not control the generator switching device when the Mains supply is on load.</b></p> <p>This input is used to prevent the module from loading the generator. If the generator is already on load, activating this input causes the module to unload the generator. Removing the input allows the generator to be loaded again.</p>
Idle Running IEEE 37.2 – 18 Accelerating or Decelerating Device	This input instructs the module to give a <i>Run at Idle speed</i> command to the engine either via an output configured to <i>Idle Running</i> or by data commands when used with supported electronic engines.
Inhibit Scheduled Run IEEE 37.2 – 3 Checking Or Interlocking Relay	This input is used to provide a mean of disabling a scheduled run.
Inhibit SMS Remote Start	This input is used to provide a means of disabling remote starts by SMS
Lamp Test	This input is used to provide a test facility for the front panel indicators fitted to the module. When the input is activated all LEDs illuminate.
Load Share Inhibit	This input disables the kW & kvar share control when in parallel

Parameter descriptions are continued overleaf...

Function	Description
Low Fuel Level Switch IEEE 37.2 - 71 Liquid Level Switch	This input is used to allow feedback for low fuel level.
Main Config Select	This input is used to select the <i>Main</i> configuration when <i>Alternative Configurations</i> are enabled.
Mains Parallel Mode	This input is used to configure the load-sharing module as to how it operates when in parallel. If the input is not active, the module communicates with other controllers to maintain equal share of the load between systems. If the <i>Mains Parallel Mode</i> input is active, the controller does not communicate with others, but instead ramps up to the pre-configured level for Base Load or Fixed Export mode with the Mains supply.
Manual Breaker Mode	When breaker control is set to <i>Active On Input</i> , this input is used to activate the <i>Manual Breaker Control</i> .
MSC Alarms Inhibit	<p><b>▲ NOTE: The MSC Old Version alarm is not inhibited when this input is active.</b></p> <p>If this input is active, all MSC failure related alarms are inhibited from activating even if the fault is active.</p>
Oil Pressure Switch IEEE 37.2 – 63 Pressure Switch	A digital normally open or closed oil pressure switch gives this input. It allows low oil pressure protection.
Open Generator IEEE 37.2 - 52 AC circuit breaker	Opens the generator breaker. Used to simulate the <i>Open Generator Breaker</i> button externally.
Remote Start Dead Bus Synchronising	<p><b>▲ NOTE: For further details, refer to the section entitled <i>Advanced Options</i> elsewhere in this document.</b></p> <p>This input is used to enable a Dead Bus Synchronising start and must be used in conjunction with another starting signal such as <i>Remote Start on Load</i>.</p>
Remote Start Off Load	If this input is active, operation is similar to the 'Remote Start on load' function except that the generator is not instructed to take the load. This function is used where an engine only run is required e.g. for exercise.
Remote Start On Load	When in auto mode, the module performs the start sequence and transfer load to the generator. In Manual mode, the load is transferred to the generator if the engine is already running, however in manual mode, this input does not generate start/stop requests of the engine.
Remote Start On Load Demand	If this input is active, the load demand start up and shut down scheme is active when two or more generators are running in parallel. Upon activation, all sets start a race for the bus. The first available set closes onto the dead bus and the others synchronise to it. Once the sets are on load they compare load levels and redundant sets commence a shutdown sequence and return to standby until the load level is such that they are required.
Reset Electrical Trip	<p><b>▲ NOTE: For further details, refer to the section entitled <i>Reset Electrical Trip</i> elsewhere in this document.</b></p> <p>This input is used to enable the <i>Reset Electrical Trip</i> function when the module is configured to do so.</p>
Reset Maintenance Alarm 1	Provides an external digital input to reset the maintenance alarm 1
Reset Maintenance Alarm 2	Provides an external digital input to reset the maintenance alarm 2
Reset Maintenance Alarm 3	Provides an external digital input to reset the maintenance alarm 3

Parameter descriptions are continued overleaf...

Function	Description
Simulate Auto Button	<p><b>▲ NOTE: If a call to start is present when AUTO MODE is entered, the starting sequence begins. Call to Start comes from a number of sources depending upon module type and configuration and includes (but is not limited to) : Remote start input present, Mains failure, Scheduled run, Auxiliary Mains failure input present, Telemetry start signal from remote locations.</b></p> <p>This input mimics the operation of the 'Auto' button and is used to provide a remotely located Auto mode push button.</p>
Simulate Lamp Test / Alarm Mute Button	<p>This input is used to provide a test facility for the front panel indicators fitted to the module. When the input is activated all LED's illuminate. The input also serves a second function, in that it also provides a mute signal to silence the audible alarm. The input is recognised by the module as though it was the Push button on the module itself being operated.</p>
Simulate Manual Button	<p>This input mimics the operation of the 'Manual' button and is used to provide a remotely located Manual mode push button.</p>
Simulate Start Button	<p>This input mimics the operation of the 'Start' button and is used to provide a remotely located start push button.</p>
Simulate Stop Button	<p>This input mimics the operation of the 'Stop' button and is used to provide a remotely located stop/reset push button.</p>
Speed Lower	<p><b>▲ NOTE: This input has no effect when using the internal analogue system to control the governor.</b></p> <p>This is operational in Manual Mode only, when the breaker is open. On systems where internal relays are used to control the governor, this input is used to decrease the speed.</p>
Speed Raise	<p><b>▲ NOTE: This input has no effect when using the internal analogue to control the governor.</b></p> <p>This is operational in Manual Mode only, when the breaker is open. On systems where internal relays are used to control the governor, this input is used to increase the speed.</p>
Start Pause IEEE 37.2 - 3 Checking or Interlocking Relay	<p>This input is intended to be used to allow the generator start sequence to commence, but not to complete. This feature is used with air start engines for example to give a controlled start sequence. The function operates such that if the 'Start pause' input is active and an engine start is commanded, the module performs its start sequence thus:</p> <p>The pre-heat output (if used) is activated for the duration of the pre-heat timer.</p> <p>The Fuel output then is energised and the module then enters a pause state - 'Awaiting clear to start'. If the 'start pause' signal becomes inactive at this time then the module continues its normal start sequence.</p> <p>The 'start pause' mode uses the 'manual crank limit' timer and if this expires during the 'Awaiting clear to start' state then a 'Fail to start' alarm is generated and the set shutdown.</p>

Parameter descriptions are continued overleaf...

Function	Description
Stop and Panel Lock	<p>Combined function input that instructs the module to enter <i>STOP</i> mode and also perform the <i>Panel Lock</i> function.</p> <p>Once the input is active, the module does not respond to operation of the mode select or start buttons.</p> <p>The operator is still able to view the various instrumentation pages etc. (<i>Front panel configuration access is still possible while the system lock is active</i>).</p>
Telemetry Panel Lock	<p>Once the input is active, the module does not respond to mode changes or breaker control by telemetry.</p> <p>The operator is still able to control and view the various instrumentation pages through the front panel buttons.</p>
Voltage Droop Enable	<p><b>▲ NOTE: For further details on the <i>Voltage Droop</i> function, refer to the section entitled <i>Load Control</i> elsewhere in this document.</b></p> <p>This input is used to disable the standard isochronous kvar load share function and enable the <i>Voltage Droop</i> function within the DSE module.</p>
Volts Lower	<p><b>▲ NOTE: This input has no effect when using the internal analogue system to control the AVR</b></p> <p>This is operational in Manual Mode only, when the breaker is open. On systems where internal relays are used to control the AVR, this input is used to increase the volts.</p>
Volts Raise	<p><b>▲ NOTE: This input has no effect when using the internal analogue system to control the AVR</b></p> <p>This is operational in Manual Mode only, when the breaker is open. On systems where internal relays are used to control the AVR, this input is used to decrease the volts.</p>
Water in Fuel	<p>Some engines are fitted with water separators, that have a switch indicator for water detection.</p> <p>This input is used to provide protection against high water content in the fuel, where a switch is fitted to the fuel filter. The action for this alarm is configurable under the <i>Engine Protections</i> page in the module configuration.</p>

## 2.5 OUTPUTS

The *Outputs* section is subdivided into smaller sections. Select the required section with the mouse.

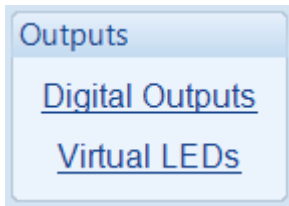

### 2.5.1 DIGITAL OUTPUTS

These labels match the typical wiring

As this example shows outputs A and B are greyed out as the engine type is selected as Conventional Diesel.

Relay Outputs (Supplied From Emergency Stop Input)		
Output	Source	Polarity
Output A	Fuel Relay	Energise
Output B	Start Relay	Energise

Relay Outputs (Volts Free)		
Output	Source	Polarity
Output C (N/C)	Not Used	De-Energise
Output D	Close Gen Output	Energise

Relay Outputs (DC Supply Out)		
Output	Source	Polarity
Output E	Preheat During Preheat Timer	Energise
Output F	Common Alarm	Energise
Output G	Audible Alarm	Energise
Output H	System In Auto Mode	Energise
Output I	Fuel Pump Control	Energise
Output J	Fuel Level Low Alarm	Energise
Output K	Not Used	Energise
Output L	Not Used	Energise

Parameter	Description
Source	Select the output source to control the state of the output See section entitled <i>Output Sources</i> for details of all available functions
Polarity	Select the digital output polarity: <b>De-Energise:</b> When the output source is true, the output deactivates. <b>Energise:</b> When the output source is true, the output activates.

## 2.5.2 VIRTUAL LEDS

The virtual LEDs provide a configuration of 'status' items. These items are not available for viewing on the module but are seen in the SCADA section of the PC software, or read by third party systems (i.e. BMS or PLCs) using the Modbus protocol.

### Virtual LEDs

#### LED Configuration

	Source	Polarity
LED 1	Generator Available ▾	Lit ▾
LED 2	Not Used ▾	Lit ▾
LED 3	Not Used ▾	Lit ▾
LED 4	Not Used ▾	Lit ▾
LED 5	Not Used ▾	Lit ▾
LED 6	Not Used ▾	Lit ▾
LED 7	Not Used ▾	Lit ▾
LED 8	Not Used ▾	Lit ▾
LED 9	Not Used ▾	Lit ▾
LED 10	Not Used ▾	Lit ▾
LED 11	Not Used ▾	Lit ▾
LED 12	Not Used ▾	Lit ▾
LED 13	Not Used ▾	Lit ▾
LED 14	Not Used ▾	Lit ▾
LED 15	Not Used ▾	Lit ▾
LED 16	Not Used ▾	Lit ▾
LED 17	Not Used ▾	Lit ▾
LED 18	Not Used ▾	Lit ▾
LED 19	Not Used ▾	Lit ▾
LED 20	Not Used ▾	Lit ▾

Parameter	Description
Source	Select the output source to control the state of the output See section entitled <i>Output Sources</i> for details of all available functions
Polarity	Select the digital input polarity: <b>Lit:</b> When the output source is true, the virtual LED activates <b>Unlit:</b> When the output source is true, the virtual LED deactivates.

### 2.5.3 OUTPUT SOURCES

The list of output sources available for configuration of the module digital outputs.

Under the scope of IEEE 37.2, function numbers is also used to represent functions in microprocessor devices and software programs. Where the DSE output functions is represented by IEEE 37.2, the function number is listed below.

Output Source	Activates...	Is Not Active....
Not Used	The output does not change state (Unused)	
1 Constant Power Factor Mode	Active when the <i>Reactive Mode 1 Constant Power Factor</i> is selected.	
1 Constant Power Mode (Default)	Active when the <i>Power Mode 1 Constant Power (Default)</i> is selected.	
2 Frequency-Power Mode	Active when the <i>Power Mode 2 Frequency Power</i> is selected.	
2 Voltage-Reactive Power Mode	Active when the <i>Reactive Mode 2 Voltage Reactive Power</i> is selected.	
3 Power-Power Factor Mode	Active when the <i>Reactive Mode 3 Power Power Factor</i> is selected.	
3 Voltage-Power Mode	Active when the <i>Power Mode 3 Voltage Power</i> is selected.	
4 Constant Reactive Power Mode (Default)	Active when the <i>Reactive Mode 4 Constant Reactive Power (Default)</i> is selected.	
Air Flap Alarm	This output indicates that the air-flap is closed; to operate it requires an input configured as 'Air-flap closed' connected to the external air-flap switch.	
Air Flap Relay	Normally used to control an air flap, this output becomes active upon an Emergency Stop or Over-speed situation.	Inactive when the set has come to rest
Alarm Mute	This input is used to silence the audible alarm from an external source such as a remote mute switch.	
Alarm Reset	This input is used to reset any latched alarms from a remote location. It is also used to clear any latched warnings which may have occurred (if configured) without having to stop the engine.	
All Available Sets Are On The Bus	This output indicates that all the available sets in the Multiset load sharing system are closed onto the generator bus. This output is used to close an external breaker to allow the generator bus to power the load. 'Available sets' are sets in auto mode with no alarms present. So sets not in auto mode, or sets that have alarms present are not considered to be 'available sets'.	
Alternative Config 1, 2 or 3 Selected	Active when the alternative configuration is selected.	
Alternative Language Selected	Active when the configured <i>Alternative Language Select</i> digital input is active	
Analogue Input A, B, C & D (Digital)	Active when the relevant analogue input, configured as digital input, is active	
Arm Safety On Alarms	Becomes active at the end of the <i>safety delay</i> timer whereupon all alarms configured to 'From Safety On' become active	Inactive when : When the set is at rest In the starting sequence before the Safety Delay timer has expired
Audible Alarm IEEE 37.2 – 74 Alarm Relay	Use this output to activate an external sounder or external alarm indicator. Operation of the Mute pushbutton resets this output once activated	Inactive if no alarm condition is active or if the Mute pushbutton was pressed
Auto Run Inhibited	Active when the <i>Auto Run Inhibit</i> function is active	

Parameter descriptions are continued overleaf...

Output Source	Activates...	Is Not Active...
Auto Start Inhibit	Active when the <i>Auto-Start Inhibit</i> function is active	
AVR Data Fail	Active when the AVR Data Fail alarm is active, indicating communication failure with the CAN AVR.	
AVR Fault	Active when the AVR Fault alarm is active, indicating an alarm detection on the CAN AVR.	
AVR Maximum Trim Limit Reached	Indicates that the analogue AVR output has reached 100%. This indicates a fault with the control of the AVR (including connection error), incorrect setting of SW2, or that the alternator has reached its maximum capacity.	
Battery High Voltage IEEE 37.2 – 59 DC Overvoltage Relay	This output indicates that a Battery Over voltage alarm has occurred	Inactive when battery voltage is not High
Battery Low Voltage IEEE 37.2 – 27 DC Undervoltage Relay	This output indicates that a Battery Under Voltage alarm has occurred.	Inactive when battery voltage is not Low
Bus Live	This output indicates that a voltage has been detected on the bus. Once the voltage on the bus is detected above the “Dead bus relay setting”, it is no longer considered a ‘dead-bus’ and the generator needs to synchronise in order to get onto the bus.	
Bus Not Live	This output indicates that the generator bus remains ‘dead’ after closing the generator load breaker.	
Bus Phase Rotation Alarm	This output indicates that the module has detected a phase sequence error on the bus.	
Calling For Scheduled Run	Active during a <i>Scheduled Run</i> request from the inbuilt <i>Scheduler</i> .	
Charge Alternator Failure Shutdown	Active when the charge alternator shutdown alarm is active	
Charge Alternator Failure Warning	Active when the charge alternator warning alarm is active	
Charger ID0, ID1, ID2, ID3 Common Shutdown	Active when the DSE module detects a Common Shutdown alarm on the relevant DSE Intelligent Charger connected to the DSEnet with the respective ID.	
Charger ID0, ID1, ID2, ID3 Common Warning	Active when the DSE module detects a Common Warning alarm on the relevant DSE Intelligent Charger connected to the DSEnet with the respective ID.	
Check Sync IEEE 37.2 – 25 Synchronising Or Synchronising Check Relay	Indicates that the internal check synchroscope has determined that the supplies are in sync.	
Clear Mains Decoupling	Active when the <i>Clear Mains Decoupling Alarms</i> digital input is active.	
Clock Pulse	Also called ‘heartbeat’, it activates and deactivates every few milliseconds to indicate that the module is powered up. It stops energising during write configuration to the module.	
Close Gen Output IEEE 37.2 – 52 AC Circuit Breaker	Used to control the load switching device. Whenever the module selects the generator to be on load this control source is activated.	Inactive whenever the generator is not required to be on load
Close Gen Output Pulse IEEE 37.2 – 52 AC Circuit Breaker	Used to control the load switching device. Whenever the module selects the generator to be on load this control source is activated for the duration of the Breaker Close Pulse timer, after which it becomes inactive again.	
Combined Maintenance Alarm	Active when any of the maintenance alarm is active.	
Combined Remote Start Request	Indicates that a remote start request is active.	

Parameter descriptions are continued overleaf...

Editing the Configuration

Output Source	Activates...	Is Not Active....
Combined Under and Over Frequency Alarm	Active when an <i>Under-Frequency</i> or <i>Over-Frequency Shutdown</i> alarm is active	
Combined Under and Over Frequency Warning	Active when an <i>Under-Frequency</i> or <i>Over-Frequency Warning</i> alarm is active	
Combined Under and Over Voltage Alarm	Active when an <i>Under-Voltage</i> or <i>Over-Voltage Shutdown</i> alarm is active	
Combined Under and Over Voltage Warning	Active when an <i>Under-Voltage</i> or <i>Over-Voltage Warning</i> alarm is active	
Common Alarm	Active when one or more alarms (of any type) are active	The output is inactive when no alarms are present
Common Electrical Trip	Active when one or more <i>Electrical Trip</i> alarms are active	The output is inactive when no shutdown alarms are present
Common Mains Decoupling Alarm	Indicates 1 or more of the decoupling alarm have activated	
Common Shutdown	Active when one or more <i>Shutdown</i> alarms are active	
Common Warning	Active when one or more <i>Warning</i> alarms are active	The output is inactive when no warning alarms are present
Coolant Cooler Control	Active by the <i>Coolant Cooler Control</i> in conjunction with the Coolant Temperature Sensor	
Coolant Heater Control	Active by the <i>Coolant Heater Control</i> in conjunction with the Coolant Temperature Sensor	
Cooling Down	Active when the Cooling timer is in progress	
Data Logging Active	Active when data is being logged	Inactive when: Data logging is disabled The engine is at rest and the option <i>Only Log When Engine Is Running</i> is enabled The internal memory of the module becomes full and the option <i>Keep Oldest Data</i> is enabled
DC Power On	Active when DC power is supplied to the module	
Dead Bus Synchronise Enabled	Active when Dead Bus Synchronising is enabled.	
Dead Bus Synchronise In Progress	Active when the set is running dead bus synchronising.	
De-Excite Alternator	Active during Dead Bus Synchronising start until the <i>Excitation Delay</i> timer expires	
DEF Level Low	Active when <i>DEF Level Low</i> CANbus alarm is active.	
Digital Input A, B, C, D, E, F, G, H, I, J, K & L	Active when the relevant digital input is active	
Display Heater Fitted and On	Active when the display heater is on	
DPF Auto Regen Inhibit Request	Active when the <i>DPF Auto Regen Inhibit Request</i> is active	
DPF Forced Regeneration Requested	Active when the <i>DPF Force Regeneration</i> is active	
DPF Non Mission State	Active when the <i>DPF Non-Mission State</i> is active	
DPF Regeneration In Progress	Active when the <i>DPF Regeneration</i> is in progress	
DPF Regeneration Interlock Active	Active when the <i>DPF Regeneration Interlock</i> is active	
DPTC Filter	Active when the diesel particulate filter CANbus alarm is active	

Parameter descriptions are continued overleaf...

Output Source	Activates...	Is Not Active....
Droop Enable	Active when an input configured to <i>Droop Enable</i> is active or if <i>Droop Enable</i> has been activated in the module configuration (CANbus engine only)	
Dummy Load Control (1 to 5)	Becomes active when the engine kW falls below the Dummy Load Control Trip Setting.	Inactive when the engine kW returns to above the Dummy Load Control Return setting.
Duty Select	Indicates that a digital input configured to <i>Duty Select</i> is active.	
Earth Fault Trip Alarm IEEE 37.2 – 51G or 51N Generator IDMT Earth Fault Relay	Active when the <i>Earth Fault Protection Alarm</i> is active.	
ECU (ECM) Data Fail	Becomes active when no CANbus data is received from the ECU after the safety delay timer has expired	Inactive when: <ul style="list-style-type: none"> <li>CANbus data is being received</li> <li>The set is at rest</li> <li>During the starting sequence before the safety delay timer has expired</li> </ul>
ECU (ECM) Power	Used to switch an external relay to power the CANbus ECU (ECM). Exact timing of this output is dependent upon the type of the engine ECU (ECM)	
ECU (ECM) Shutdown	The engine ECU (ECM) has indicated that a Shutdown alarm is present.	Inactive when no Shutdown alarm from the ECU (ECM) is present
ECU (ECM) Stop	Active when the DSE controller is requesting that the CANbus ECU (ECM) stops the engine.	
ECU (ECM) Warning	The engine ECU (ECM) has indicated that a Warning alarm is present.	Inactive when no Warning alarm from the ECU (ECM) is present
EJP1 / EJP2	Active when an input configured for <i>EJP1</i> or <i>EJP2</i> is active	
Electrical Trip From 8660	Becomes active when the DSE8660 records an electrical trip.	Inactive when the electrical trip isn't present on the 8660.
Electrical Trip Reset	Becomes active when the electrical trip has been reset.	Inactive on the next electrical trip alarm or when the generator is at rest.
Electrical Trip Reset Count Exhausted	Becomes active when the maximum number of resets within specified time frame has been reached.	Inactive when the generator is at rest.
Electrical Trip Stop Inhibited	Becomes active when the generator has been on load, there is an active electrical trip alarm and inhibit engine stop has been enabled.	
Emergency Stop IEEE 37.2 – 5 Stopping Device	Active when the <i>Emergency Stop</i> input has been activated	
Energise To Stop	Normally used to control an <i>Energise to Stop</i> solenoid, this output becomes active when the controller wants the set to stop running.	Becomes inactive a configurable amount of time after the set has stopped. This is the <i>ETS hold time</i> .
Expansion 2130 Address 0 to 3 Analogue Input E to H (Digital)	Active when the relevant analogue input on the relevant DSE2130 is configured as a digital input and is active	
Expansion 2130 Address 0 to 3 Analogue Input A to D (Digital)	Active when the relevant digital input on the relevant DSE2130 is active	

Parameter descriptions are continued overleaf...

Output Source	Activates...	Is Not Active....
Expansion 2130 Address 0 to 3 Input E to H High Shutdown	Active when the relevant analogue input on the relevant DSE2130 high alarm is active	
Expansion 2130 Address 0 to 3 Input E to H High Warning	Active when the relevant analogue input on the relevant DSE2130 high pre-alarm is active	
Expansion 2130 Address 0 to 3 Input E to H Low Shutdown	Active when the relevant analogue input on the relevant DSE2130 low alarm is active	
Expansion 2130 Address 0 to 3 Input E to H Low Warning	Active when the relevant analogue input on the relevant DSE2130 low pre-alarm is active	
Expansion 2131 Address 0 to 3 Analogue Input A to J (Digital)	Active when the relevant analogue input on the relevant DSE2131 is configured as a digital input and is active	
Expansion 2131 Address 0 to 3 Input A to J High Shutdown	Active when the relevant analogue input on the relevant DSE2131 high alarm is active	
Expansion 2131 Address 0 to 3 Input A to J High Warning	Active when the relevant analogue input on the relevant DSE2131 high pre-alarm is active	
Expansion 2131 Address 0 to 3 Input A to J Low Shutdown	Active when the relevant analogue input on the relevant DSE2131 low alarm is active	
Expansion 2131 Address 0 to 3 Input A to J Low Warning	Active when the relevant analogue input on the relevant DSE2131 low pre-alarm is active	
Expansion 2133 Address 0 to 3 Input A to H High Shutdown	Active when the relevant analogue input on the relevant DSE2133 high alarm is active	
Expansion 2133 Address 0 to 3 Input A to H High Warning	Active when the relevant analogue input on the relevant DSE2133 high pre-alarm is active	
Expansion 2133 Address 0 to 3 Input A to H Low Shutdown	Active when the relevant analogue input on the relevant DSE2133 low alarm is active	
Expansion 2133 Address 0 to 3 Input A to H Low Warning	Active when the relevant analogue input on the relevant DSE2133 low pre-alarm is active	
Fail To Start IEEE 37.2 - 48 Incomplete Sequence Relay	Becomes active if the set is not seen to be running after the configurable number of start attempts	
Fail To Stop IEEE 37.2 - 48 Incomplete Sequence Relay	If the set is still running a configurable amount of time after it has been given the stop command, the output becomes active. This configurable amount of time is the <i>Fail to Stop Timer</i> .	
Fail to Synchronise IEEE 37.2 - 48 Incomplete Sequence Relay	Becomes active if the module fails to synchronise after the <i>fail to sync</i> timer.	
Fan Control	Energises when the engine becomes available (up to speed and volts). This output is designed to control an external cooling fan. When the engine stops, the cooling fan remains running for the duration of the Fan Overrun Delay.	
Fault Ride Through Event	Becomes active during a <i>Fault Ride Through</i> event, the module generates a Warning alarm.	Becomes inactive when there is no <i>Fault Ride Through</i> event.

Parameter descriptions are continued overleaf...

Output Source	Activates...	Is Not Active....
Flexible Sensor A, B, C or D High Alarm	Active when the relevant flexible sensor high alarm is active	
Flexible Sensor A, B, C or D High Pre-Alarm	Active when the relevant flexible sensor high pre-alarm is active	
Flexible Sensor A, B, C or D Low Alarm	Active when the relevant flexible sensor low alarm is active	
Flexible Sensor A, B, C or D Low Pre-Alarm	Active when the relevant flexible sensor low pre-alarm is active	
Frequency Droop Enabled	Active when the <i>Frequency Droop</i> has been activated	
Frequency Droop Input	Active when the <i>Frequency Droop Enable</i> input has been activated	
Fuel Level High Alarm	Active when the fuel level high alarm is active.	
Fuel Level High Pre-Alarm	Active when the fuel level high pre-alarm is active.	
Fuel Level Low Alarm	Active when the fuel level low alarm is active.	
Fuel Level Low Pre-Alarm	Active when the fuel level low pre-alarm is active.	
Fuel Pump Control IEEE 37.2 – 71 Level Switch	Becomes active when the <i>Fuel level</i> falls below the <i>Fuel Pump Control ON</i> setting and is normally used to transfer fuel from the bulk tank to the day tank.	If the output is already active it becomes inactive when the <i>Fuel level</i> is above the <i>Fuel Pump Control OFF</i> settings.
Fuel Relay	Becomes active when the controller requires the governor/fuel system to be active.	Becomes inactive whenever the set is to be stopped, including between crank attempts, upon controlled stops and upon fault shutdowns.
Fuel Tank Bund Level High	Active when the digital input configured for <i>Fuel Tank Bund Level High</i> is active.	
Fuel Usage Alarm IEEE 37.2 – 80 Flow Switch	Active when the <i>Fuel Usage</i> alarm becomes active	
Gas Choke On	Becomes active during starting for the duration of the Gas Choke timer. Normally used to choke a gas engine.	Inactive at all other times
Gas Ignition	Becomes active during starting.	Becomes inactive a configurable amount of time after the <i>Fuel Relay</i> becomes inactive. This is the <i>Gas Ignition Off</i> timer.
Gen Over Frequency Overshoot Alarm	Becomes active when the <i>Over Frequency Overshoot</i> alarm is active	
Gen Over Frequency Overshoot Warning	Becomes active when the <i>Over Frequency Overshoot Warning</i> alarm is active	
Generator at Rest	This output indicates that the generator is not running and no alarms are active.	
Generator Available	Becomes active when the generator is available to take load.	Inactive when <ul style="list-style-type: none"> <li>• <i>Loading voltage</i> and <i>loading frequency</i> have not been reached</li> <li>• After <i>electrical trip</i> alarm</li> <li>• During the starting sequence before the end of the warming timer.</li> </ul>
Generator Closed Aux	Active when the <i>Generator Closed Auxiliary</i> input is active	
Generator Excite IEEE 37.2 – 31 Separate Excitation Device	Used to control the excitation of the main alternator (AC).	Becomes inactive when the set is stopped.

Parameter descriptions are continued overleaf...

Output Source	Activates...	Is Not Active...
Generator Failed To Close IEEE 37.2 – 52B AC Circuit Breaker Position (Contact Open When Breaker Closed)	Active when the <i>Generator Closed Auxiliary</i> input fails to become active after the <i>Close Generator Output</i> or <i>Close Generator Output Pulse</i> becomes active	
Generator Failed to Open IEEE 37.2 - 48 Incomplete Sequence Relay	This output source is intended to be used to indicate a failure of the generator contactor or breaker. It is only used if the module is configured to use 'Generator Closed Auxiliary' feedback.	
Generator High Voltage Alarm IEEE 37.2 – 59 AC Overvoltage Relay	Active when the <i>High Voltage Shutdown</i> alarm is active	
Generator High Voltage Warning IEEE 37.2 – 59 AC Overvoltage Relay	Active when the <i>High Voltage Warning</i> alarm is active	
Generator Load Inhibited	Active when the <i>Generator Load Inhibit</i> input is active	
Generator Low Voltage Alarm IEEE 37.2 – 27 AC Undervoltage Relay	Active when the generator voltage falls below the <i>Low Voltage Alarm Trip</i> level	Inactive when <ul style="list-style-type: none"> <li>• The set is stopped</li> <li>• During starting sequence before the safety delay time has expired.</li> </ul>
Generator Low Voltage Warning IEEE 37.2 – 27 AC Undervoltage Relay	Active when the generator voltage falls below the <i>Low Voltage Pre-Alarm Trip</i> level	Inactive when <ul style="list-style-type: none"> <li>• The set is stopped</li> <li>• During starting sequence before the safety delay time has expired.</li> </ul>
Generator Over Frequency Alarm IEEE 37.2 – 81 Frequency Relay	Active when the generator frequency exceeds the <i>Over Frequency Shutdown Trip</i> level.	
Generator Over Frequency Warning IEEE 37.2 – 81 Frequency Relay	Active when the generator frequency exceeds the <i>Over Frequency Warning Trip</i> level.	
Generator Phase Rotation Alarm IEEE 37.2 – 47 Phase Sequence Relay	Active when the detected generator phase sequence is different than the configured <i>Generator Phase Rotation</i>	
Generator Reverse Power IEEE 37.2 – 32 Directional Power Relay	Active when the <i>Generator Reverse Power</i> alarm is active	
Generator Stopping	This output source indicates that the engine has been instructed to stop but has not yet come to rest. Once the engine comes to a standstill this output becomes inactive.	
Generator Under Frequency Alarm	Active when any of the <i>Generator Under Frequency Shutdown</i> or <i>Electrical Trip</i> alarm are active	
Generator Under Frequency Warning	Active when the <i>Generator Under Frequency Warning</i> alarm is active	
HEST Active	Active when the High Exhaust System Temperature CANbus alarm is active	
High Coolant Temperature Electrical Trip IEEE 37.2 – 26 Apparatus Thermal Device	Active when the <i>Coolant Temperature</i> exceeds the configured <i>High Coolant Temperature Electrical Trip</i> level	

Parameter descriptions are continued overleaf...

Output Source	Activates...	Is Not Active...
High Coolant Temperature Shutdown IEEE 37.2 – 26 Apparatus Thermal Device	Active when the <i>Coolant Temperature</i> exceeds the configured <i>High Coolant Temperature Shutdown</i> level	
High Coolant Temperature Warning IEEE 37.2 – 26 Apparatus Thermal Device	Active when the <i>Coolant Temperature</i> exceeds the configured <i>High Coolant Temperature Warning</i> level	
High Inlet Temperature Shutdown	Active when the <i>Inlet Temperature</i> exceeds the <i>High Inlet Temperature Alarm</i> setting	
High Inlet Temperature Warning	Active when the <i>Inlet Temperature</i> exceeds the <i>High Inlet Temperature Pre-Alarm</i> setting	
Idle Running	Becomes active when the controller requests that the engine runs at idle speed. As an output, this is used to give a signal to the <i>Idle Speed Input</i> on the engine speed governor (if available)	Becomes inactive when the controller requests that the engine runs at rated speed.
Inhibit Scheduled run	Active when the <i>Inhibit Scheduled run</i> input is active	
Inhibit SMS Start	Active when the input <i>Inhibit SMS Start</i> input is active	
Insufficient Capacity Available	Indicates that during parallel operation, it has been determined that the set(s) is (are) not capable of providing the power that they have been configured to deliver.	
kW Overload Alarm	Active when the measured kW are above the setting of the <i>kW overload alarm</i> values. Used to give alarms on overload, control a dummy load breaker or for load shedding functionality.	
kW Overload Warning	Active when the measured kW are above the setting of the <i>kW pre-alarm</i> values. Used to give alarms on overload, control a dummy load breaker or for load shedding functionality.	
Lamp Test	Active when the lamp test is activated by a digital input or by pressing the <i>Mute/Lamp Test</i> control button	
Load Demand Delay Active	Indicates that the set has closed onto the bus and that the <i>Load Demand Delay</i> is in progress. When this has expired, the <i>Load Demand Scheme</i> is activated.	
Load Share Inhibit	This output indicates that a digital input that has been configured as ' <i>Load Share Inhibit</i> ' is active. Refer to the ' <i>Edit Inputs</i> ' section of this manual for details.	
Load Shedding Control (1 to 5)	Becomes active when the engine kW exceeds Load Shedding Control Trip Setting.	Inactive when the engine kW returns to below the Load Shedding Control Return setting.
Loading Frequency Not Reached	Active when the generator frequency has not reached the configured <i>Loading Frequency</i> during the starting process.	
Loading Voltage Not Reached	Active when the generator voltage has not reached the configured <i>Loading Voltage</i> during the starting process.	
Loss of Mag Pickup Signal	Active when the controller senses the loss of signal from the magnetic pickup probe	
Louvre Control	Active when the fuel relay becomes active. Normally used to drive ventilation louvres for the generator set	
Low Coolant Temperature IEEE 37.2 – 26 Apparatus Thermal Device	Active when the <i>Coolant Temperature</i> falls below the <i>Low Coolant Temperature alarm</i> setting	

Parameter descriptions are continued overleaf...

Editing the Configuration

Output Source	Activates...	Is Not Active....
Low kW Load	Active when the kW level falls below configured <i>Low Load</i> alarm.	
Low Load	Indicates that the stopping sequence is beginning due to low load levels. ( <i>Load Demand Scheme</i> )	
Low Oil Pressure Shutdown IEEE 37.2 - 63 Pressure Switch	Active when the <i>Oil Pressure</i> falls below the <i>Low Oil Pressure Shutdown</i> setting	Inactive when <ul style="list-style-type: none"> <li>• The set is stopped</li> <li>• During starting sequence before the safety delay time has expired.</li> </ul>
Low Oil Pressure Warning IEEE 37.2 - 63 Pressure Switch	Active when the <i>Oil Pressure</i> falls below the <i>Low Oil Pressure Warning</i> setting	Inactive when <ul style="list-style-type: none"> <li>• The set is stopped</li> <li>• During starting sequence before the safety delay time has expired.</li> </ul>
Main Config Selected	Active when the main configuration is active	
Mains Decoupling High Frequency Stage 1,2	This output indicates that the relevant Mains decoupling high frequency alarm has been triggered.	
Mains Decoupling High Voltage Stage 1,2	This output indicates that the relevant Mains decoupling high voltage alarm has been triggered.	
Mains Decoupling Low Frequency Stage 1,2	This output indicates that the relevant Mains decoupling low frequency alarm has been triggered.	
Mains Decoupling Low Voltage Stage 1,2	This output indicates that the relevant Mains decoupling low voltage alarm has been triggered.	
Mains Parallel Mode Input	Active when the <i>Mains Parallel Mode</i> digital input becomes active.	
Mains ROCOF	Indicates that the ROCOF protection (when in parallel with mains) has triggered.	
Mains Vector Shift	Indicates that the Vector Shift protection (when in parallel with mains) has triggered.	
Maintenance Alarm 1, 2 or 3 Due	Active when the relevant maintenance alarm is due.	
MPU Open Circuit	This output indicates that the module has detected an open circuit failure in the Magnetic Pickup transducer circuit.	
MSC Alarms Disabled	Active when the <i>MSC Alarms Inhibit</i> digital input function is active.	
MSC Data Error	Indicates bad data transfer on both of the MultiSet Comms (MSC) Links.	
MSC Electrical Trip	Active when any <i>MSC Alarm</i> is active.	
MSC Failure	Indicates when the <i>MSC Failure</i> alarm is active on both MultiSet Comms (MSC) Links.	
MSC ID Error	Active when another controller is using the same <i>MSC ID</i> on either of the MultiSet Comms (MSC) Links.	
MSC Link 1 or 2 Data Error	Indicates bad data transfer on the first or second MultiSet Comms (MSC) Link.	
MSC Link 1 or 2 Failure	Active when the <i>MSC Failure</i> alarm is active on the first or second MultiSet Comms (MSC) Link.	
MSC Link 1 or 2 Too Few Sets	Indicates that the number of sets connected on the first or second MultiSet Comms (MSC) Link is lower than the <i>Minimum Sets Required</i> setting.	
MSC Old Units On the Bus	Active when any MSC versions are incorrect/incompatible on either MultiSet Comms (MSC) Links.	
MSC Too Few Sets	Indicates that the number of sets connected on the MultiSet Comms (MSC) Link is lower than the <i>Minimum Sets Required</i> setting.	

Parameter descriptions are continued overleaf...

Output Source	Activates...	Is Not Active....
Mute / Lamp Test Button Pressed	This output indicates that the alarm mute / Lamp test push button is being operated. Once the button is released, the output becomes inactive.	
Negative Phase Sequence Alarm	Active when the <i>Negative Phase Sequence</i> alarm is active	
New Coil x	<div style="border: 2px solid black; padding: 5px;"> <p> <b>NOTE: The PLC Coil may be renamed in the PLC Editor which effects on the function name listed in the Output Sources. For more details refer to DSE Publication: 057-314 Advanced PLC Software Manual which is found on our website: <a href="http://www.deepseelectronics.com">www.deepseelectronics.com</a></b></p> </div>	
	Active when the relevant <i>PLC Coil</i> is active.	
No Loading Command	This output indicates that the module is not calling for the generator load switch to be closed. When the module closes the generator load switch, this output becomes inactive.	
Oil Pressure Sensor Open Circuit	Active when the <i>Oil Pressure Sensor</i> is detected as being open circuit.	
Open Gen Output IEEE 37.2 – 52 AC Circuit Breaker	Used to control the load switching device. Whenever the module selects the generator to be off load this control source is activated.	Inactive whenever the generator is required to be on load
Open Gen Output Pulse IEEE 37.2 – 52 AC Circuit Breaker	Used to control the load switching device. Whenever the module selects the generator to be off load this control source is activated for the duration of the Breaker Open Pulse timer, after which it becomes inactive again.	
Out of Sync	Indicates that the <i>out of sync</i> alarm has been triggered.	
Over Current IDMT Alarm	Active when the <i>Over Current IDMT</i> alarm is active	
Over Current Immediate Warning	Active when the <i>Over Current Immediate Warning</i> alarm is active	
Over Speed Shutdown IEEE 37.2 – 12 Over Speed Device	Active when the <i>Over Speed Shutdown</i> alarm is active	
Over Speed Warning IEEE 37.2 – 12 Over Speed Device	Active when the <i>Over Speed Warning</i> alarm is active	
Overspeed Overshoot Alarm IEEE 37.2 – 12 Over Speed Device	Active when the <i>Over Speed Overshoot</i> alarm is active	
Overspeed Overshoot Warning IEEE 37.2 – 12 Over Speed Device	Active when the <i>Over Speed Overshoot Warning</i> alarm is active	
Panel locked	This output indicates that the module ' <i>Panel Lock</i> ' is active. If the Panel lock input is active, the module does not respond to operation of the Mode select or start buttons. This allows the module to be placed into a specific mode (such as Auto) and then secured. The operation of the module is not affected and the operator is still able to view the various instrumentation pages etc. ( <i>Front panel configuration access is barred while system lock is active</i> ).	
Panel Locked By Digital Input	This output indicates that a digital input that has been configured as ' <i>Panel Lock</i> ' is active. If the Panel lock input is active, the module does not respond to operation of the Mode select or start buttons. This allows the module to be placed into a specific mode (such as Auto) and then secured. The operation of the module is not affected and the operator is still able to view the various instrumentation pages etc. ( <i>Front panel configuration access is barred while system lock is active</i> ). Refer to the ' <i>Edit Inputs</i> ' section of this manual for details.	

Parameter descriptions are continued overleaf...

Output Source	Activates...	Is Not Active...
Panel Locked By Telemetry	This output indicates that remote ' <i>Panel Lock</i> ' via telemetry is active. If the Panel lock is active, the module does not respond to operation of the Mode select or start buttons. This allows the module to be controller remotely without local interference. The operation of the module is not affected and the local operator is still able to view the various instrumentation pages etc. ( <i>Front panel configuration access is barred while system lock is active</i> ).	
PLC Output Flag 1 to 100	 <b>NOTE: PLC Output Flags are supported on module versions up to v5.1</b> Active when the <i>PLC Flag</i> is active	
Preheat During Preheat Timer	Becomes active when the preheat timer begins. Normally used to control the engine preheat glow-plugs.	Inactive when : <ul style="list-style-type: none"> <li>• The set is stopped</li> <li>• The preheat timer has expired</li> </ul>
Preheat Until End Of Cranking	Becomes active when the preheat timer begins. Normally used to control the engine preheat glow-plugs.	Inactive when : <ul style="list-style-type: none"> <li>• The set is stopped</li> <li>• The set has reached <i>crank disconnect</i> conditions</li> </ul>
Preheat Until End Of Safety Timer	Becomes active when the preheat timer begins. Normally used to control the engine preheat glow-plugs.	Inactive when : <ul style="list-style-type: none"> <li>• The set is stopped</li> <li>• The set has reached the end of the <i>safety delay</i> timer</li> </ul>
Preheat Until End of Warming Timer	Becomes active when the preheat timer begins. Normally used to control the engine preheat glow-plugs.	Inactive when : <ul style="list-style-type: none"> <li>• The set is stopped</li> <li>• The set has reached the end of the <i>warming</i> timer</li> </ul>
Protections Disabled	Active when protections are turned off (Unticked) in the configuration.	
Remote Control 1 to 10	A series of output sources that are controlled by remote control in the SCADA section of the software, used to control external circuits.	
Remote Start From Digital Input	Active when any configured <i>Remote Start</i> digital input is active.	
Remote Start Off Load	Active when the <i>Remote Start Off Load</i> input is active	
Remote Start On Load	Active when the <i>Remote Start On Load</i> input is active	
Remote Start On Load Demand	Indicates that the module's input is active for remote start on load demand. Also indicates that the controller has received a remote start on load signal from the 8860 via the MSC link.	
Remote Start Over MSC	Indicates that the controller has received a remote start on load signal from the 8860 via the MSC link.	
Reset AVR to Datum	This output is intended to be used in conjunction with an electronic or motorised potentiometer, which has a 'centre pot' type input. This output is activated whenever the module needs to reset the potentiometer to its centre position.	
Reset Governor to Datum	This output is intended to be used in conjunction with an electronic or motorised potentiometer, which has a 'centre pot' type input. This output is activated whenever the module needs to reset the potentiometer to its centre position.	
Reset Maintenance 1, 2 or 3	Active when the relevant <i>Maintenance Alarm Reset</i> is active	
Return Delay In Progress	This output source is active to indicate that the return timer is running.	
Scheduled Auto Start Inhibit	Active during a <i>Scheduled Auto Start Inhibit</i> request from the inbuilt <i>Scheduler</i> .	
SCR Inducement	Active when <i>SCR Inducement CAN Alarm</i> is active	

Parameter descriptions are continued overleaf...

*Editing the Configuration*

<b>Output Source</b>	<b>Activates...</b>	<b>Is Not Active....</b>
Short Circuit Generator	This output indicates that the module has detected a short circuit on the generator output.	
Shutdown Blocked	Becomes active when protections are disabled and one of the parameters goes out of limits	
Simulate Auto Button	Active when the <i>Simulate Auto Button</i> digital input is active	
Simulate Start Button	Active when a digital input configured to <i>Simulate Start Button</i> is active	
Simulate Stop Button	Active when the <i>Simulate Stop Button</i> digital input is active	
SMS Remote Start Off Load	Active when the set receives an SMS message to start and run off load	
SMS Remote Start On Load	Active when the set receives an SMS message to start and run load	
Speed Lower Relay	This output is used to give a speed lower signal to the external governor or electronic pot.	
Speed Raise Relay	This output is used to give a speed raise signal to the external governor or electronic pot.	
Start Delay in Progress	This output source is active to indicate that the module's internal start delay timer is running. Once this timer expires the module initiates its start sequence.	
Start Paused	Active when the <i>Start Pause</i> digital input is active.	
Start Relay IEEE 37.2 – 54 Turning Gear Engaging Device	Active when the controller requires the cranking of the engine.	
Starting Alarm	This output is used to supply an external sounder with a signal that the engine is about to start. The output is active after the start delay time, during the pre heat delay (if used) and continues until the set starts.	
Starting Alarms Armed	This output indicates that the starting alarms are now enabled. It is used to control external logic circuitry. Starting alarms are armed as soon as the module commences starting of the engine and remain armed until the engine is at rest.	
Stop and Panel lock	Active when the <i>Stop And Panel Lock</i> digital input is active	
Stop Button Pressed	This output indicates that the stop pushbutton is being operated. Once the button is released, the output becomes inactive.	
Synching Enabled	This output indicates that the synchronisation feature has been enabled.	
System Healthy	This output indicates that the module is in <i>Auto</i> mode and there are no alarms present.	
System in Auto Mode	Active when Auto mode is selected	
System in Manual Mode	Active when Manual mode is selected	
System in Stop Mode	Active when Stop mode is selected	
Telemetry Active	Active when the communication port is live and for a short time after transmission stops. Used as a relay or LED source.	
Telemetry Data Active	Active when data is being transmitted. This output changes continuously state (flash) upon data transfer. Normally used as an LED source rather than a relay source as the signal flashes repeatedly. For a similar source more suited to drive a relay, see <i>Telemetry Active</i> .	
Telemetry Panel Lock	Active when the <i>Telemetry Panel Lock</i> digital input is active	
Telemetry Start in Auto Mode	Active when a <i>Remote Start Request</i> is sent over by communication	

Parameter descriptions are continued overleaf...

*Editing the Configuration*

<b>Output Source</b>	<b>Activates...</b>	<b>Is Not Active...</b>
Under Speed Alarm	Active when any of the <i>Underspeed Shutdown</i> alarm is active	
Under Speed Warning	Active when the <i>Underspeed Warning</i> alarm is active.	
Voltage Droop Enabled	Active when the <i>Voltage Droop</i> has been activated	
Voltage Droop Input	Active when the <i>Voltage Droop Enable</i> input has been activated	
Voltage Lower Relay	Used when the <i>internal relays</i> scheme of AVR control is used. This output is used to drive a motorised potentiometer or Voltage Lower input of an AVR	
Voltage Raise Relay	Used when the <i>internal relays</i> scheme of AVR control is used. This output is used to drive a motorised potentiometer or Voltage Raise input of an AVR	
Waiting for Electrical Trip Reset	Active when an electrical trip alarm is active and waiting for it to be reset.	Inactive when the electrical trip alarm has been reset or when the generator is at rest.
Waiting For Generator	This output indicates that the engine has been instructed to start but has not yet become available. Once the generator becomes available this output becomes in-active. (Available = Generator Frequency and Voltage levels are above the ' <i>Loading</i> ' levels set in the configuration)	
Water In Fuel	Active when the digital input function <i>Water In Fuel</i> is active.	
Working Adjusted Nominal Volts	Active when the nominal voltage is different than the configured nominal voltage. Indicates that the nominal voltage was changed through the module FPE and set to a different voltage than the configured nominal voltage.	

## 2.6 TIMERS

Many timers are associated with alarms. Where this occurs, the timer for the alarm is located on the same page as the alarm setting. Timers not associated with an alarm are located on the timers page. The *Timers* page is subdivided into smaller sections. Select the required section with the mouse.

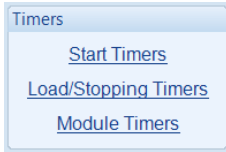

### 2.6.1 START TIMERS

#### Start Delay



Click and drag to change the setting.  
Timers increment in steps of 1 second up to one minute, then in steps of 30 seconds up to 30minutes, then in steps of 30 minutes thereafter (where allowed by the limits of the timer).

Timer	Description
Remote Start Off Load	The amount of time delay before starting in AUTO mode. This timer is activated upon the <i>Remote Start Off Load</i> command being issued. Typically this timer is applied to prevent starting upon fleeting start signals.
Remote Start On Load	The amount of time delay before starting in AUTO mode. This timer is activated upon the <i>Remote Start On Load</i> command being issued. Typically this timer is applied to prevent starting upon fleeting start signals.
Telemetry Start	The amount of time delay before starting in AUTO mode. This timer is activated upon a <i>Remote Start</i> command being received from a MODBUS master. Typically this timer is applied to prevent starting upon fleeting start signals.

Parameter descriptions are continued overleaf...

**Start Timers**

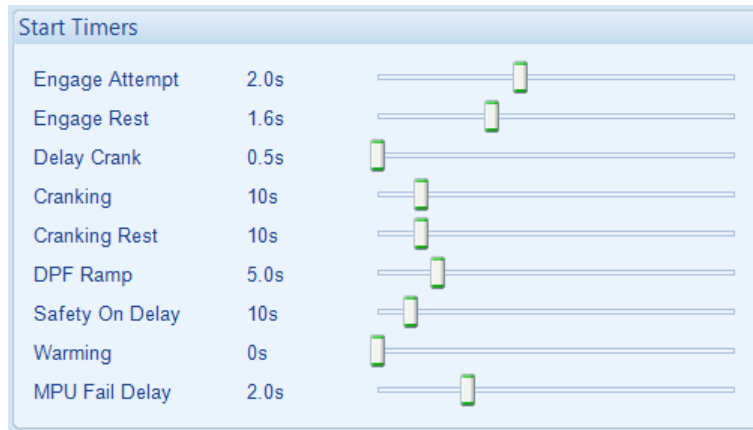

Timer	Description
Engage Attempt	<p><b>▲ NOTE: Only available if using magnetic pick-up and multiple engage attempts.</b></p> <p>The amount of time the module attempts to engage the starter motor during each engage attempt. If the Magnetic Pick-up is not detecting movement of the flywheel when this timer expires, the engage attempt terminates. When the engage fails consecutively for the configured number of <i>Engage Attempts</i>, the <i>Fail to Engage</i> alarm is activated.</p>
Engage Rest	<p><b>▲ NOTE: Only available if using magnetic pick-up and multiple engage attempts.</b></p> <p>The amount of time the module waits between attempts to engage the starter.</p>
Delay Crank	<p>The amount of time delay between the fuel relay and the crank relay energising. This is typically used to allow fuel systems to prime.</p>
Cranking	The amount of time for each crank attempt
Crank Rest	The amount of time between multiple crank attempts.
DPF Ramp	The amount of time that the engine takes to run up to rated speed after running at its DPF speed.
Safety On Delay	The amount of time at start-up that the controller ignores oil pressure and engine speed and other delayed alarms. This is used to allow the engine to run up to speed before protections are activated.
Warming	The amount of time the engine runs before being allowed to take load. This is used to warm the engine to prevent excessive wear.
MPU Fail Delay	<p><b>▲ NOTE: Only available if using Magnetic pick-up</b></p> <p>The amount of time during which the module must receive a speed signal once cranking has commenced. If no signal is present, the engine is stopped, and a <i>Loss of Speed Sensing</i> alarm given.</p>

## 2.6.2 LOAD / STOPPING TIMERS

### Load Timers

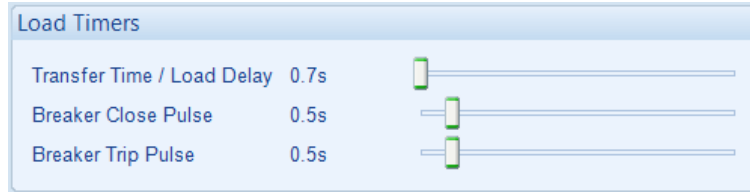

Timer	Description
Transfer Time	The amount of time before closing the breaker when the set becomes available.
Breaker Close Pulse	The amount of time that <i>Breaker Close Pulse</i> signal is present when the request to close the load switch is given.
Breaker Trip Pulse	The amount of time that <i>Breaker Open Pulse</i> signal is present when the request to open the load switch is given.

### Stopping Timers

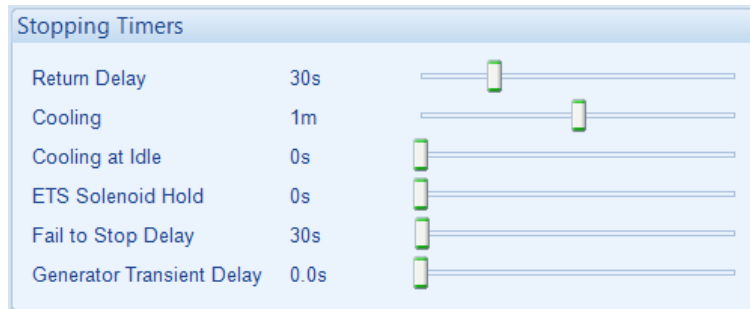

Timer	Description
Return Delay	A delay, used in auto mode only, that allows for short term removal of the request to stop the set before action is taken. This is usually used to ensure the set remains on load before accepting that the start request has been removed.
Cooling	The amount of time that the set is made to run OFF LOAD before being stopped. This is to allow the set to cool down and is particularly important for engines with turbo chargers.
Cooling At Idle	The amount of time that the set is made to run OFF LOAD and at Idle Speed before being stopped.
ETS Solenoid Hold	The amount of time the <i>Energise to stop</i> solenoid is kept energised after the engine has come to rest. This is used to ensure the set has fully stopped before removal of the stop solenoid control signal.
Fail To Stop Delay	If the set is called to stop and is still running after the <i>fail to stop</i> delay, a <i>Fail to Stop</i> alarm is generated.
Generator Transient Delay	A delay used to allow for short term transients to be ignored before raising an alarm. Operates upon Engine under/over speed, Generator under/over voltage / frequency.

### 2.6.3 MODULE TIMERS

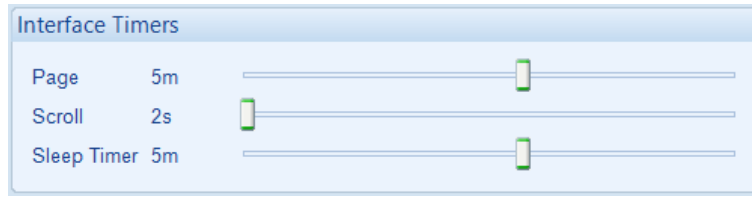

Timer	Description
Page	If the module is left unattended for the duration of the <i>LCD Page Timer</i> it reverts to show the <i>Status</i> page.
Scroll	The scroll time between parameters on a selected page
Sleep Timer	If the module is left unattended for the duration of the <i>Sleep Timer</i> , it goes into sleep mode to save power.

## 2.7 GENERATOR

The *Generator* section is subdivided into smaller sections. Select the required section with the mouse

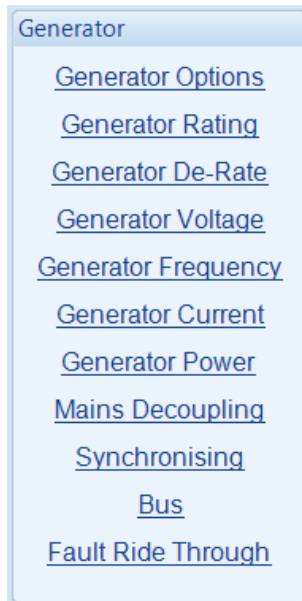

## 2.7.1 GENERATOR OPTIONS

### Generator Options

The screenshot shows the 'Generator Options' configuration window. At the top, there are four main settings: 'Alternator Fitted' (checked), 'Poles' (4), 'AC System' (3 Phase, 4 Wire), and 'VT fitted' (checked). Below these is a schematic diagram of a three-phase star connection. The phases are labeled L1(U), L2(V), and L3(W), with a neutral line N. The terminals are connected to a terminal block with terminals 44, 45, 46, and 47. At the bottom, there are 'Primary' and 'Secondary vPhPh' voltage settings, with 'Primary' set to 1100 and 'Secondary' set to 110. Two callout boxes provide additional information: one pointing to the 'AC System' dropdown and another pointing to the 'VT fitted' checkbox.

Parameter	Description
Alternator Fitted	<input type="checkbox"/> = There is no alternator in the system, it is an <i>engine only</i> application <input checked="" type="checkbox"/> = An alternator is fitted to the engine, it is a generator application.
Poles	The number of poles on the alternator
AC System	Select the AC topology of the generator from the following list: <b>2 Phase, 3 Wire L1 - L2</b> <b>2 Phase, 3 Wire L1 - L3</b> <b>3 Phase, 3 Wire</b> <b>3 Phase, 4 Wire</b> <b>3 Phase, 4 Wire Delta L1 - N - L2</b> <b>3 Phase, 4 Wire Delta L1 - N - L3</b> <b>3 Phase, 4 Wire Delta L2 - N - L3</b> <b>Single Phase, 2 Wire</b> <b>Single Phase, 3 Wire L1 - L2</b> <b>Single Phase, 3 Wire L1 - L3</b>
VT Fitted	<input type="checkbox"/> = The voltage sensing to the controller is direct from the alternator <input checked="" type="checkbox"/> = The voltage sensing to the controller is via Voltage Transformers (VTs or PTs)  This is used to step down the generated voltage to be within the controller voltage specifications. By entering the <i>Primary</i> and <i>Secondary</i> voltages of the transformer, the controller displays the <i>Primary</i> voltage rather than the actual measured voltage.  This is typically used to interface the DSE module to high voltage systems (i.e. 11kV)

**Generator Phase Rotation**

Parameter	Description
Generator Phase Rotation IEEE 37.2 – 47 Phase Sequence Relay	<input type="checkbox"/> = Generator phase rotation is not checked. <input checked="" type="checkbox"/> = An electrical trip alarm is generated when the measured phase rotation is not as configured.

**Breaker Control**

Parameter	Description
Enable Breaker Alarms	<input type="checkbox"/> = Alarm is disabled <input checked="" type="checkbox"/> = The <i>Generator Breaker Alarms</i> are enabled.
Fail To Open Delay	When the <i>Open Generator</i> output is activated, if the configured <i>Generator Closed Auxiliary</i> digital input does not become inactive within the <i>Generator Fail To Open Delay</i> timer, the alarm is activated
Fail To Close Delay	When the <i>Close Generator</i> output is activated, if the configured <i>Generator Closed Auxiliary</i> digital input does not become active within the <i>Generator Fail To Close Delay</i> timer, the alarm is activated

## 2.7.2 GENERATOR RATING

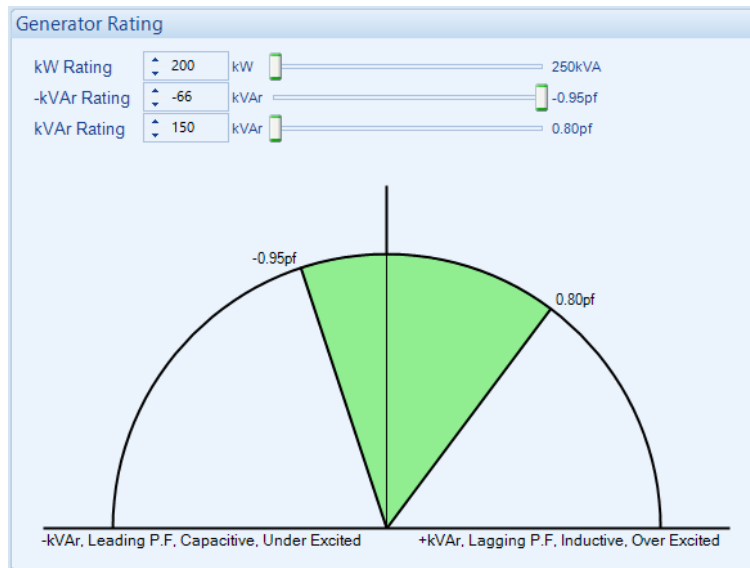

Parameter	Description
kW Rating	The kW rating of the generator. This is used for all <i>Generator Power</i> functions in addition to the rating in which the kW load sharing calculations are based on.
kvar Rating	<p>The positive kvar rating of the generator. This is used for all <i>AVR</i> functions in addition to the rating in which the kvar load sharing calculations are based on. To calculate the kvar rating of a genset:</p> <ul style="list-style-type: none"> <li>Most generators are rated for a lagging power factor (kW / kVA) of 0.8</li> <li>From Pythagoras: <math display="block">\cos \Phi = \frac{\text{kW}}{\text{kVA}}</math> <math display="block">\cos \Phi = 0.8</math> <math display="block">\Phi = \cos^{-1} 0.8 = 36.87^\circ</math> </li> <li>From this, the kvar rating of the typical 0.8 pf rated generator is: <math display="block">\tan \Phi = \frac{\text{kvar}}{\text{kW}}</math> <math display="block">\text{kvar} = \tan 36.87^\circ \times \text{kW}</math> <math display="block">\text{kvar} = 0.75 \times \text{kW}</math> </li> <li>Or to simplify this, the kvar rating of a 0.8 pf rated generator is <math>\frac{3}{4}</math> of the kW rating (kvar rating = 75% of kW rating)</li> </ul>
-kvar Rating	<p>The negative kvar rating of the generator. This is only used to limit the magnitude of negative kvar which the generator produces when in parallel with the mains.in addition to the rating in which the kvar load sharing calculations are based on. To calculate the kvar rating of a genset:</p> <ul style="list-style-type: none"> <li>Most generators are rated for a leading power factor of 0.95</li> <li>From Pythagoras: <math display="block">\cos \Phi = \frac{\text{kW}}{\text{kVA}}</math> <math display="block">\cos \Phi = 0.95</math> <math display="block">\Phi = \cos^{-1} 0.95 = 18.20^\circ</math> </li> <li>From this, the kvar rating of the typical 0.95 pf rated generator is: <math display="block">\tan \Phi = \frac{\text{kvar}}{\text{kW}}</math> <math display="block">\text{kvar} = \tan 18.20^\circ \times \text{kW}</math> <math display="block">\text{kvar} = 0.33 \times \text{kW}</math> </li> <li>Or to simplify this, the kvar rating of a 0.95 pf rated generator is <math>\frac{1}{3}</math> of the kW rating (-kvar rating = 33% of kW rating)</li> </ul>

### 2.7.3 GENERATOR DE-RATE

**NOTE:** When the *Power De-Rate* or the *Reactive Power De-Rate* are enabled, the DSE module shows the kW De-Rate and kvar De-Rate pages on its LCD display. For more information refer to DSE Publication: *057-254 DSE8610 MKII Operator Manual* which is found on our website: [www.deepseaelectronics.com](http://www.deepseaelectronics.com)

**NOTE:** The *Power De-Rate* and the *Reactive Power De-Rate* are adjusted from the *PLC Editor*, through the *Gencomm Override* functionality, or from the Scada configuration section, or through MODBUS. For more information, refer to sections entitled PLC and De-Rate elsewhere in this document.

**NOTE:** This section is greyed out when the *Load Demand Compatibility* is selected to "86xx up to v5.1".

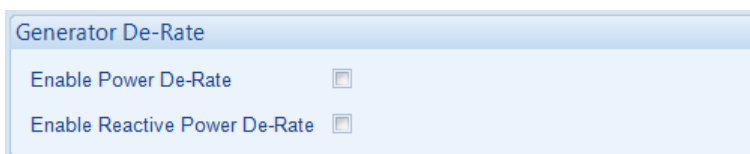

Parameter	Description
Enable Power De-Rate	<input type="checkbox"/> = Power De-Rate is disabled <input checked="" type="checkbox"/> = Power De-Rate is enabled. The Generator kW Rating is De-Rated based on the PLC driven condition.
Enable Reactive Power De-Rate	<p><b>NOTE:</b> When a kvar De-Rate % is applied, the same percentage is used to de-rate both the +kvar &amp; -kvar ratings of the generator.</p> <input type="checkbox"/> = Reactive Power De-Rate is disabled <input checked="" type="checkbox"/> = Reactive Power De-Rate is enabled. The Generator kVAr Rating is De-Rated based on the PLC driven condition.

## 2.7.4 GENERATOR VOLTAGE

### Under Voltage Alarms

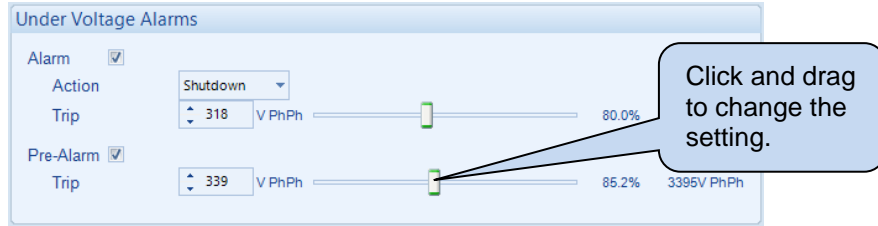

Parameter	Description
Generator Under Voltage Alarm IEEE 37.2 - 27AC Undervoltage Relay	<input type="checkbox"/> = Generator Under Volts does NOT give an alarm <input checked="" type="checkbox"/> = Generator Under Volts gives an alarm in the event of the generator output falling below the configured <i>Under Volts Alarm Trip</i> value for longer than the <i>Generator Transient Delay</i> . The <i>Under-volts Alarm Trip</i> value is adjustable to suit user requirements.
Action	Select the type of alarm required from the list: <b>Electrical Trip</b> <b>Shutdown</b> For details of these, see the section entitled <i>Alarm Types</i> elsewhere in this document.
Generator Under Voltage Pre-Alarm IEEE 37.2 - 27AC Undervoltage Relay	<input type="checkbox"/> = Generator Under Volts does NOT give a warning alarm <input checked="" type="checkbox"/> = Generator Under Volts gives a warning alarm in the event of the generator output falling below the configured <i>Under Volts Pre-Alarm Trip</i> value for longer than the <i>Generator Transient Delay</i> . The <i>Under-volts Pre-Alarm Trip</i> value is adjustable to suit user requirements.

### Loading Voltage

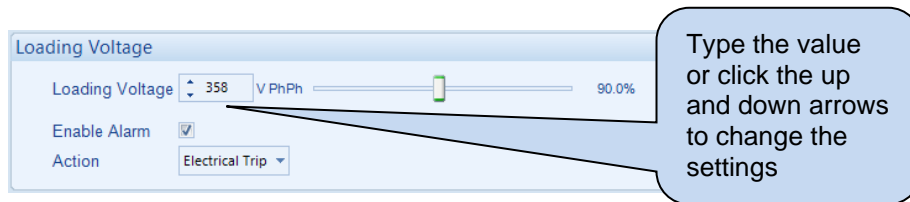

Parameter	Description
Loading Voltage	This is the minimum voltage the generator must be operating at before the module considers it available to take the load. It is also the voltage above the under voltage trip that the generator output must return to before the module considers that the supply is back within limits. (i.e. With an under voltage trip of 184 V and a loading voltage of 207 V, the output voltage must return to 207 V following an under voltage event to be considered within limits.)
Enable Alarm	<input type="checkbox"/> = Alarm is disabled. <input checked="" type="checkbox"/> = Upon starting and after the <i>Safety On Delay Timer</i> expires, if the generator output voltage fails to reach the <i>Loading Voltage</i> set point, the <i>Loading Voltage Not Reached</i> alarm is activated.
Action	Select the type of alarm required from the list: <b>Electrical Trip</b> <b>Indication</b> <b>Shutdown</b> <b>Warning</b> For details of these, see the section entitled <i>Alarm Types</i> elsewhere in this document.

**Nominal Voltage**

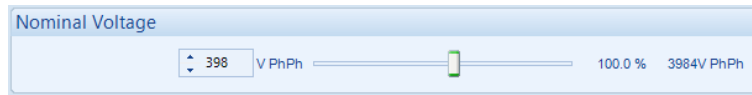

Parameter	Description
Nominal Voltage	This is used to calculate the percentages of the alarm set points and also instruct the module what voltage to adjust the generator to whilst running on load

**Over Voltage Alarms**

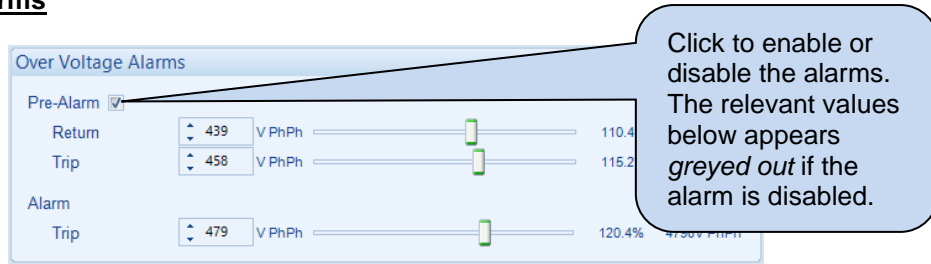

Parameter	Description
Generator Over Voltage Pre-Alarm IEEE 37.2 – 59 AC Overvoltage Relay	<input type="checkbox"/> = Alarm is disabled <input checked="" type="checkbox"/> = Generator Over Volts gives a warning alarm in the event of the generator output voltage rising above the configured <i>Over Volts Pre-Alarm Trip</i> value for longer than the <i>Generator Transient Delay</i> . The <i>Warning</i> is automatically reset when the generator output voltage falls below the configured <i>Return</i> level. The <i>Over Volts Pre-Alarm Trip</i> value is adjustable to suit user requirements.
Generator Over Voltage Alarm IEEE 37.2 – 59 AC Overvoltage Relay	Generator Over Volts gives a <i>Shutdown</i> alarm in the event of the generator output rising above the configured <i>Over Volts Alarm Trip</i> value for longer than the <i>Generator Transient Delay</i> . The <i>Over-volts Alarm Trip</i> value is adjustable to suit user requirements.

## 2.7.5 GENERATOR FREQUENCY

### Under Frequency Alarms

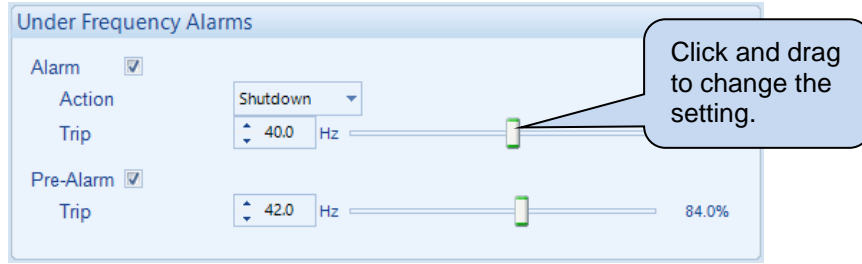

Parameter	Description
Generator Under Frequency Alarm <a href="#">IEEE 37.2 -81 Frequency Relay</a>	<input type="checkbox"/> = Generator Under Frequency does NOT give an alarm <input checked="" type="checkbox"/> = Generator Under Frequency gives an alarm in the event of the generator output frequency falling below the configured <i>Under Frequency Alarm Trip</i> value for longer than the <i>Generator Transient Delay</i> . The <i>Under-frequency Alarm Trip</i> value is adjustable to suit user requirements.
Action	Select the type of alarm required from the list: <b>Electrical Trip</b> <b>Shutdown</b> For details of these, see the section entitled <i>Alarm Types</i> elsewhere in this document.
Generator Under Frequency Pre-Alarm <a href="#">IEEE 37.2 -81 Frequency Relay</a>	<input type="checkbox"/> = Generator Under Frequency does NOT give a warning alarm <input checked="" type="checkbox"/> = Generator Under Frequency gives a warning alarm in the event of the generator output frequency falling below the configured <i>Under Frequency Pre-Alarm Trip</i> value for longer than the <i>Generator Transient Delay</i> . The <i>Under Frequency Pre-Alarm Trip</i> value is adjustable to suit user requirements.

### Loading Frequency

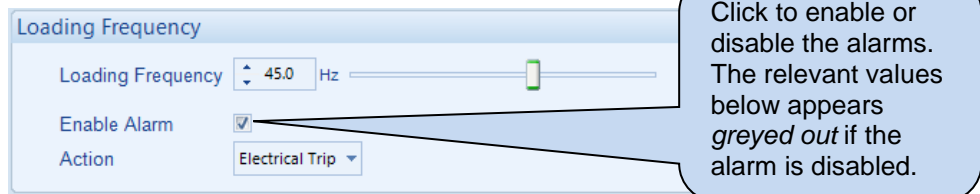

Parameter	Description
Loading Frequency	This is the minimum frequency the generator must be operating at, before the module considers it available to take the load. It is also the frequency above the under frequency trip that the generator output must return to before the module considers that the supply is back within limits. (i.e. With an under-frequency trip of 42.0 Hz and a loading frequency of 45.0 Hz, the output frequency must return to 45.0 Hz following an under frequency event to be considered within limits.)
Enable Alarm	<input type="checkbox"/> = Alarm is disabled. <input checked="" type="checkbox"/> = Upon starting and after the <i>Safety On Delay Timer</i> expires, if the generator output frequency fails to reach the <i>Loading Frequency</i> set point, the <i>Loading frequency Not Reached</i> alarm is activated.
Action	Select the type of alarm required from the list: <b>Electrical Trip</b> <b>Indication</b> <b>Shutdown</b> <b>Warning</b> For details of these, see the section entitled <i>Alarm Types</i> elsewhere in this document.

**Nominal Frequency**

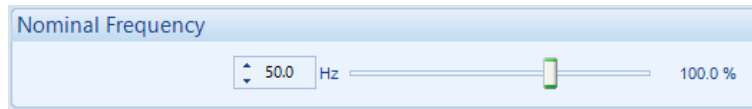

Parameter	Description
Nominal Frequency	This is used to calculate the percentages of the alarm setpoints and also instruct the module what frequency to adjust the generator to whilst running on load

**Over Frequency Alarms**

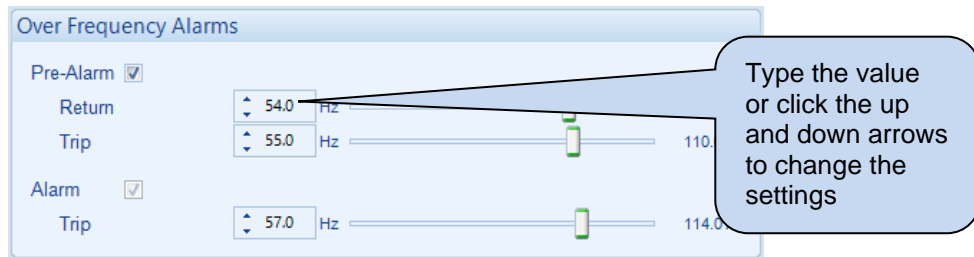

Parameter	Description
Generator Over Frequency Pre-Alarm IEEE 37.2 -81 Frequency Relay	<input type="checkbox"/> = Alarm is disabled <input checked="" type="checkbox"/> = Generator Over Frequency gives a warning alarm in the event of the generator output frequency rising above the configured <i>Over frequency Pre-Alarm Trip</i> value for longer than the <i>Generator Transient Delay</i> . The <i>Warning</i> is automatically reset when the generator output frequency falls below the configured <i>Return</i> level. The <i>Over Frequency Pre-Alarm Trip</i> value is adjustable to suit user requirements.
Generator Over Frequency Alarm IEEE 37.2 -81 Frequency Relay	<input type="checkbox"/> = Alarm is disabled <input checked="" type="checkbox"/> = Generator Over Frequency gives a <i>Shutdown</i> alarm in the event of the generator output rising above the configured <i>Over Frequency Alarm Trip</i> value for longer than the <i>Generator Transient Delay</i> . The <i>Over Frequency Alarm Trip</i> value is adjustable to suit user requirements.

## 2.7.6 GENERATOR CURRENT

The *generator* section is subdivided into smaller sections. Select the required section with the mouse.



### 2.7.6.1 GENERATOR CURRENT OPTIONS

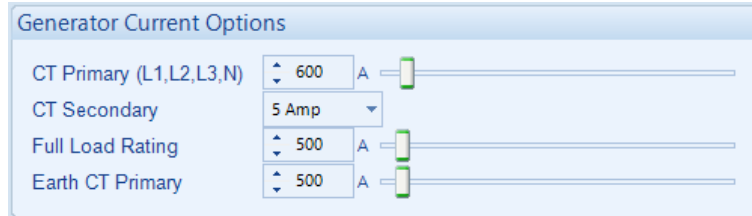

Parameter	Description
CT Primary (L1, L2, L3, N)	Primary rating of the three phase current transformers.
CT Secondary	Secondary rating of all the current transformers, options are: <b>1 Amp</b> <b>5 Amp</b>
Full Load Rating	This is the full load current rating of the alternator.
Earth CT Primary	Primary rating of the earth fault current transformers.

## 2.7.6.2 GENERATOR CURRENT ALARMS

### Overcurrent Alarm

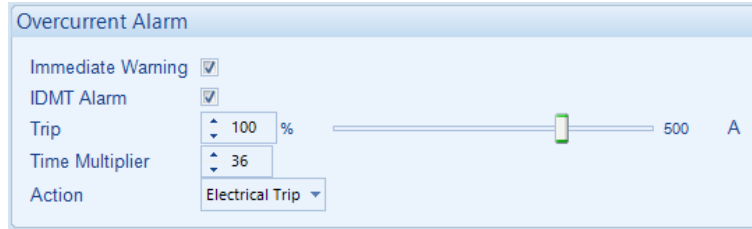

The overcurrent alarm combines a simple warning trip level combined with a fully functioning IDMT curve for thermal protection.

Parameter	Description
Immediate Warning IEEE 37.2 -50 instantaneous overcurrent relay	If the <i>Immediate Warning</i> is enabled, the controller generates a <i>warning alarm</i> as soon as the <i>Trip</i> level is reached. The alarm automatically resets once the generator loading current falls below the <i>Trip</i> level (unless <i>All Warnings are latched</i> is enabled). For further advice, consult the generator supplier.
IDMT Alarm IEEE 37.2 -51 AC time overcurrent relay (shutdown / electrical trip)	If the <i>Over Current IDMT Alarm</i> is enabled, the controller begins following the IDMT 'curve' when the current on any phase passes the <i>Trip</i> setting.  If the <i>Trip</i> is surpassed for an excess amount of time, the <i>IDMT Alarm</i> triggers ( <i>Shutdown</i> or <i>Electrical Trip</i> as selected in <i>Action</i> ).  The larger the over circuit fault, the faster the trip. The speed of the trip is dependent upon the fixed formula:  $T = \frac{t}{\left(\frac{I_A}{I_T} - 1\right)^2}$  <b>Where:</b> <i>T</i> is the tripping time in seconds <i>I<sub>A</sub></i> is the actual measured current of the most highly loaded line (L1, L2 or L3) <i>I<sub>T</sub></i> is the <i>Trip</i> setting in amps <i>t</i> is the <i>Time Multiplier</i> setting and also represents the tripping time in seconds at twice full load (when $I_A/I_T = 2$ ).
Trip	The percentage of alternator full load current at which the IDMT Alarm curve starts to operate from.
Time Multiplier	The time multiplier constant throughout the IDMT curve. It also represents the tripping time in seconds at 200% alternator full load current.
Action	Select the type of alarm required from the list: <b>Electrical Trip</b> <b>Indication</b> <b>Shutdown</b> <b>Warning</b> For details of these, see the section entitled <i>Alarm Types</i> elsewhere in this document.

### Overcurrent Protection Explanation

The settings shown in the example below are a screen capture of the DSE factory settings, taken from the DSE Configuration Suite PC Software for a brushless alternator.

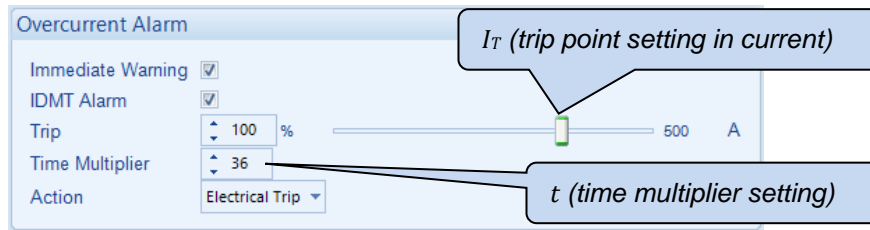

These settings provide for normal running of the generator up to 100% full load. If full load is surpassed, the *Immediate Warning* alarm is triggered and the set continues to run.

The effect of an overload on the generator is that the alternator windings begin to overheat; the aim of the *IDMT Alarm* is to prevent the windings being overload (heated) too much. The amount of time that the alternator is safely overloaded is governed by how high the overload condition is.

The default settings as shown above allow for an overload of the alternator to the limits of the *Typical Brushless Alternator* whereby 110% overload is permitted for 1 hour or 200% overload is permitted for 36 seconds.

If the alternator load reduces, the controller then *follows* a cooling curve. This means that a second overload condition may trip soon after the first as the controller *knows* if the windings have not cooled sufficiently.

For further details on the *Thermal Damage Curve* of your alternator, refer to the alternator manufacturer and generator supplier.

### Creating A Spreadsheet For the Over Current IDMT Curve

The formula used:

$$T = \frac{t}{\left(\frac{I_A}{I_T} - 1\right)^2}$$

#### Where:

$T$  is the tripping time in seconds

$I_A$  is the actual measured current of the most highly loaded line (L1, L2 or L3)

$I_T$  is the *Trip* setting in amps

$t$  is the *Time Multiplier* setting and also represents the tripping time in seconds at twice full load (when  $I_A/I_T = 2$ ).

The equation is simplified for addition into a spreadsheet. This is useful for 'trying out' different values of  $t$  (*Time Multiplier* setting) and viewing the results, without actually testing this on the generator.

	A	B	C	D	E	F
1		1.01	1.02	1.03	1.05	1.06
2	36	360000	90000	40000	14400	10000

$t$  (*time multiplier setting*)

$T$  (*tripping time in seconds*)

$I_A/I_T$  (*multiple of the Trip setting from 1.01 to 3.0 in steps of 0.1*)

The formula for the *Tripping Time* cells is:

$=\$A2/POWER((B\$1-1),2)$

## Over Current Alarm IDMT Curves

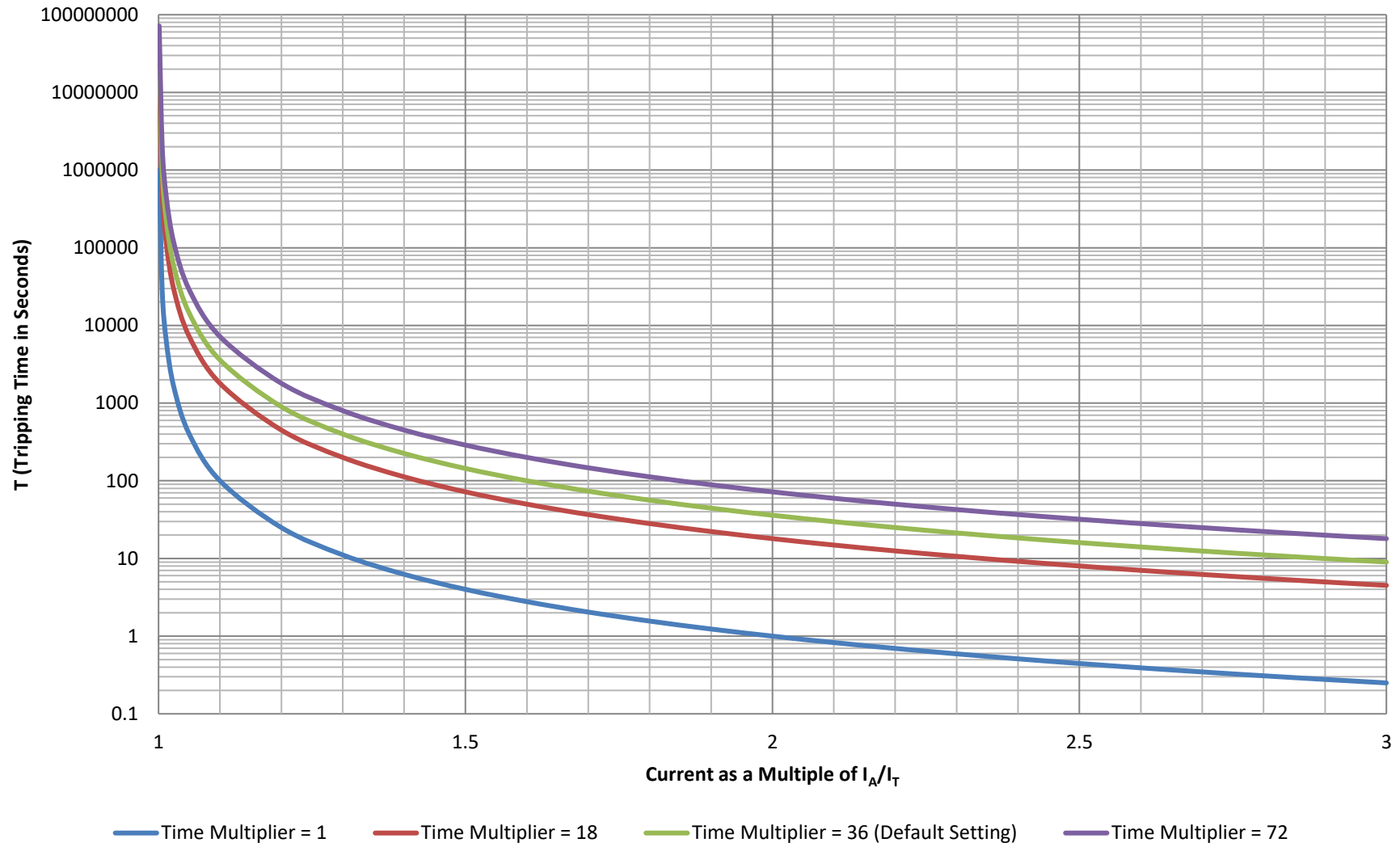

**Negative Phase Sequence**

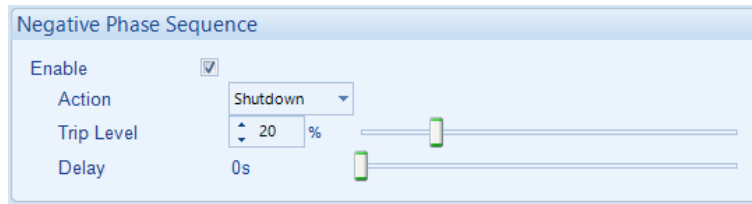

Unbalanced loads cause negative sequence current in the alternator stator. These currents cause harmonics which eventually leads to overheating and melting of the rotor. An unbalanced-load is, however, permissible within limits.

For recommended settings contact your alternator manufacturer.

Parameter	Description
Negative Phase Sequence Enable IEEE C37.2 - 46 Phase-Balance Current Relay	<p>If the <i>Negative Phase Sequence</i> is enabled, the controller protects against unbalanced loads.</p> <p>The controller achieves this by measuring the difference between the minimum phase load and the maximum phase load. If this difference is greater than the <i>Trip</i> setting for the configured <i>Delay</i>, the <i>Negative Phase Sequence</i> alarm triggers.</p> <p>The magnitude of the tripping current is calculated by:</p> $I_T = I_R \times T_P \times P_N$ <p><b>Where:</b></p> <ul style="list-style-type: none"> <li><math>I_T</math> is the unbalanced tripping point setting amps.</li> <li><math>I_R</math> is the rated <i>Full Load Rating</i> current per phase of the alternator</li> <li><math>T_P</math> is the <i>Trip Level</i> setting as a percentage (e.g. 20% would be 0.2)</li> <li><math>P_N</math> is the number of phases the module is configured to monitor</li> </ul>
Action	<p>Select the type of alarm required from the list:</p> <p><b>Electrical Trip</b> <b>Shutdown</b> <b>Warning</b></p> <p>For details of these, see the section entitled <i>Alarm Types</i> elsewhere in this document.</p>
Trip Level	The trip as a percentage of alternator full load current
Delay	Set the amount of time before the <i>Negative Phase Sequence</i> activates.

**Short Circuit Alarm**

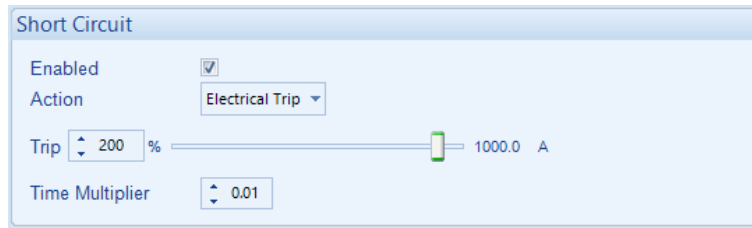

Parameter	Description
Short Circuit Enable IEEE C37.2 – 51 IDMT Short Circuit Relay	<p>If the <i>Short Circuit Alarm</i> is enabled, the controller begins following the IDMT 'curve' when the current on any phase passes the <i>Trip</i> setting.</p> <p>If the <i>Trip</i> is surpassed for an excess amount of time, the <i>IDMT Alarm</i> triggers (<i>Shutdown</i> or <i>Electrical trip</i> as selected in <i>Action</i>).</p> <p>The larger the short circuit fault, the faster the trip. The speed of the trip is dependent upon the fixed formula:</p> $T = \frac{t \times 0.14}{\left(\left(\frac{I_A}{I_T}\right)^{0.02} - 1\right)}$ <p>Where:</p> <ul style="list-style-type: none"> <li><math>T</math> is the tripping time in seconds (accurate to <math>\pm 5\%</math> or <math>\pm 50</math> ms (whichever is greater))</li> <li><math>I_A</math> is the actual measured current</li> <li><math>I_T</math> is the <i>Trip</i> setting in current</li> <li><math>t</math> is the <i>Time Multiplier</i> setting</li> </ul>
Action	<p>Select the type of alarm required from the list:</p> <p><b>Electrical Trip</b>  <b>Indication</b>  <b>Shutdown</b>  <b>Warning</b></p> <p>For details of these, see the section entitled <i>Alarm Types</i> elsewhere in this document.</p>
Trip	The percentage of alternator full load current at which the IDMT Alarm curve starts to operate from.
Time Multiplier	The time multiplier constant throughout the IDMT curve.

### Short Circuit Protection Explanation

The settings shown in the example below are a screen capture of the DSE factory settings, taken from the DSE Configuration Suite software.

**NOTE:** Due to large inrush currents from certain loads, such as motors or transformers, the default settings for the Short Circuit alarm may need adjusting to compensate for normal operating conditions.

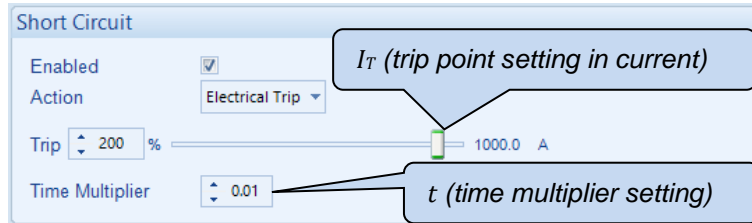

The effect of a short circuit on the generator is that the alternator stator and rotor begin to overheat; the aim of the *IDMT alarm* is to prevent the stator and rotor being overload (heated) too much. The amount of time that the alternator is safely overloaded is governed by how high the short circuit condition is.

For further details on the *Thermal & Magnetic Damage Curve* of your alternator, refer to the alternator manufacturer and generator supplier.

### Creating a Spreadsheet For the Short Circuit IDMT Curve

The formula used:

$$T = \frac{t \times 0.14}{\left(\left(\frac{I_A}{I_T}\right)^{0.02} - 1\right)}$$

Where:

- $T$  is the tripping time in seconds (accurate to  $\pm 5\%$  or  $\pm 50$  ms (whichever is greater))
- $I_A$  is the actual measured current
- $I_T$  is the *Trip* setting in current
- $t$  is the *Time Multiplier* setting

The equation is simplified for addition into a spreadsheet. This is useful for 'trying out' different values of  $t$  (*time multiplier setting*) and viewing the results, without actually testing this on the generator.

	A	B	C	D	E	F
1		1.01	1.02	1.03	1.05	1.06
2	0.01	7.034242	25	11.11111	4	2.777778

$t$  (*time multiplier setting*)

$T$  (*tripping time in seconds*)

$I_A/I_T$  (*multiple of the Trip setting from 1.01 to 3.0 in steps of 0.1*)

The formula for the *Tripping Time* cells is:

$f_x$  `=(A2*0.14)/(POWER((B$1),0.02)-1)`

## Short Circuit Alarm IDMT Curves

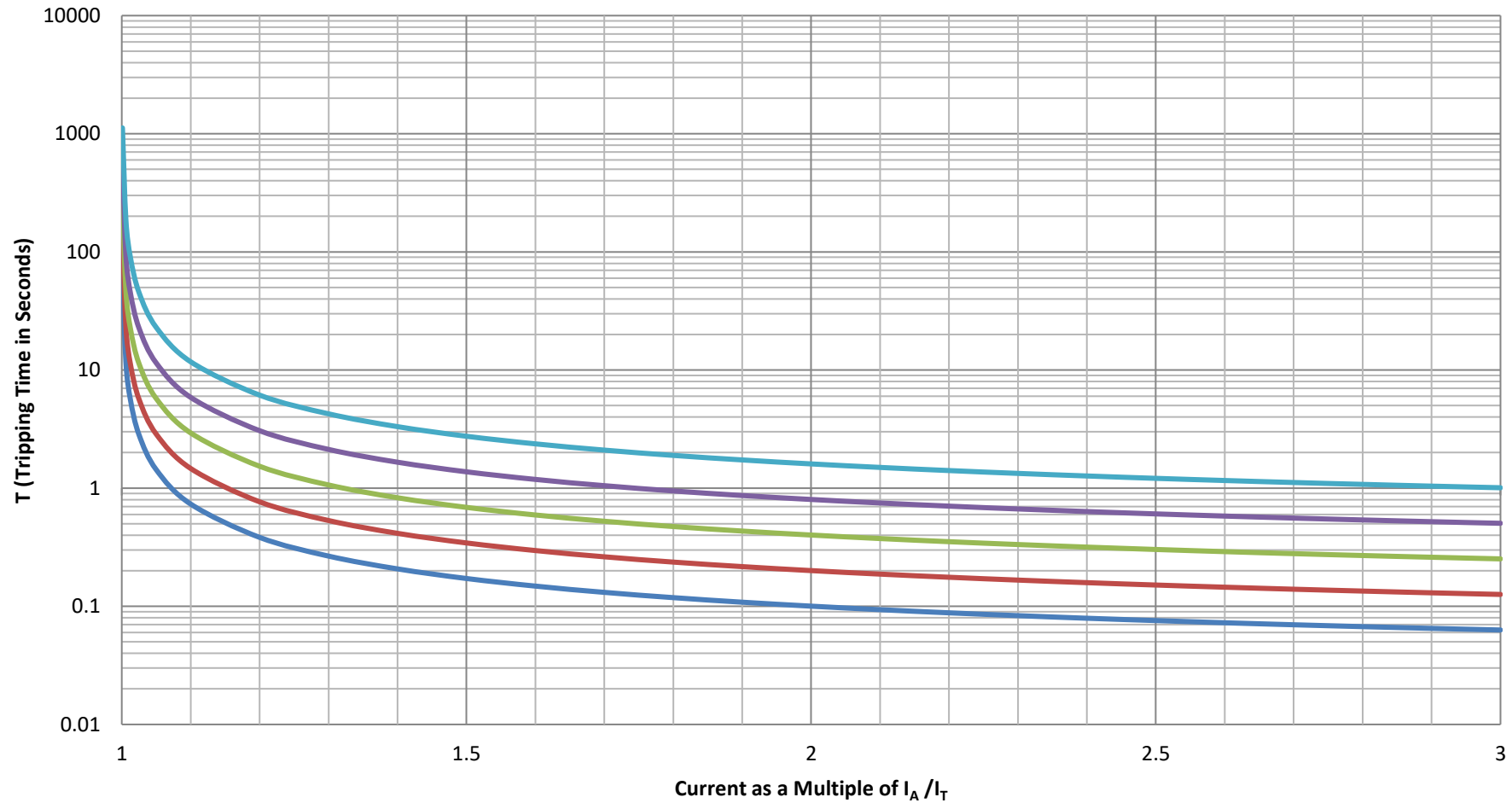

Time Multiplier = 0.01 (Default Setting)    Time Multiplier = 0.02    Time Multiplier = 0.04  
Time Multiplier = 0.08    Time Multiplier = 0.16

**Earth Fault Alarm**

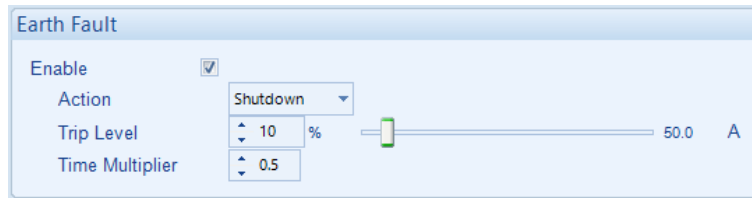

When the module is suitably connected using the 'Earth Fault CT'. The module measures Earth Fault and optionally configured to generate an alarm condition (shutdown or electrical trip) when a specified level is surpassed.

Parameter	Description
Earth Fault Enable IEEE C37.2 – 51 IDMT Earth Fault Relay	<p>If the <i>Earth Alarm</i> is enabled, the controller begins following the IDMT 'curve' when the current on any phase passes the <i>Trip</i> setting.</p> <p>If the <i>Trip</i> is surpassed for an excess amount of time, the <i>IDMT Alarm</i> triggers (<i>Shutdown</i> or <i>Electrical trip</i> as selected in <i>Action</i>).</p> <p>The larger the earth fault, the faster the trip. The speed of the trip is dependent upon the fixed formula:</p> $T = \frac{t \times 0.14}{\left(\left(\frac{I_A}{I_T}\right)^{0.02} - 1\right)}$ <p>Where:</p> <ul style="list-style-type: none"> <li><i>T</i> is the tripping time in seconds (accurate to ±5 % or ±50 ms (whichever is greater))</li> <li><i>I<sub>A</sub></i> is the actual measured current</li> <li><i>I<sub>T</sub></i> is the <i>Trip Level</i> setting in current</li> <li><i>t</i> is the <i>Time Multiplier</i> setting</li> </ul>
Action	Select the type of alarm required from the list: <b>Electrical Trip</b> <b>Indication</b> <b>Shutdown</b> <b>Warning</b> For details of these, see the section entitled <i>Alarm Types</i> elsewhere in this document.
Trip	The percentage of alternator full load current at which the IDMT Alarm curve starts to operate from.
Time Multiplier	The time multiplier constant throughout the IDMT curve.

### Earth Fault Protection Explanation

The settings shown in the example below are a screen capture of the DSE factory settings, taken from the DSE Configuration Suite software.

**NOTE:** Due to unbalanced loads or certain types of load, such as an overloaded L1 or variable frequency drives, the default settings for the Earth Fault alarm may need adjusting to compensate for normal operating conditions.

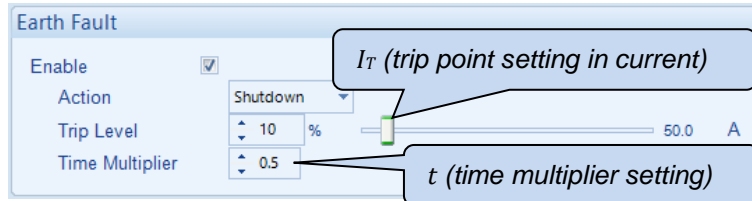

### Creating a Spreadsheet For the Earth Fault IDMT Curve

The formula used:

$$T = \frac{t \times 0.14}{\left(\left(\frac{I_A}{I_T}\right)^{0.02} - 1\right)}$$

Where:

- $T$  is the tripping time in seconds (accurate to  $\pm 5\%$  or  $\pm 50$  ms (whichever is greater))
- $I_A$  is the actual measured current
- $I_T$  is the trip point setting in current
- $t$  is the time multiplier setting

The equation is simplified for addition into a spreadsheet. This is useful for 'trying out' different values of  $t$  (*time multiplier setting*) and viewing the results, without actually testing this on the generator.

	A	B	C	D	E	F
1		1.01	1.02	1.03	1.05	1.06
2	0.01	7.034242	25	11.11111	4	2.777778

$t$  (*time multiplier setting*)

$T$  (*tripping time in seconds*)

$I_A/I_T$  (*multiple of the Trip setting from 1.01 to 3.0 in steps of 0.1*)

The formula for the *Tripping Time* cells is:

```
=($A2*0.14)/(POWER((B$1),0.02)-1)
```

# Earth Fault IDMT Alarm Curves

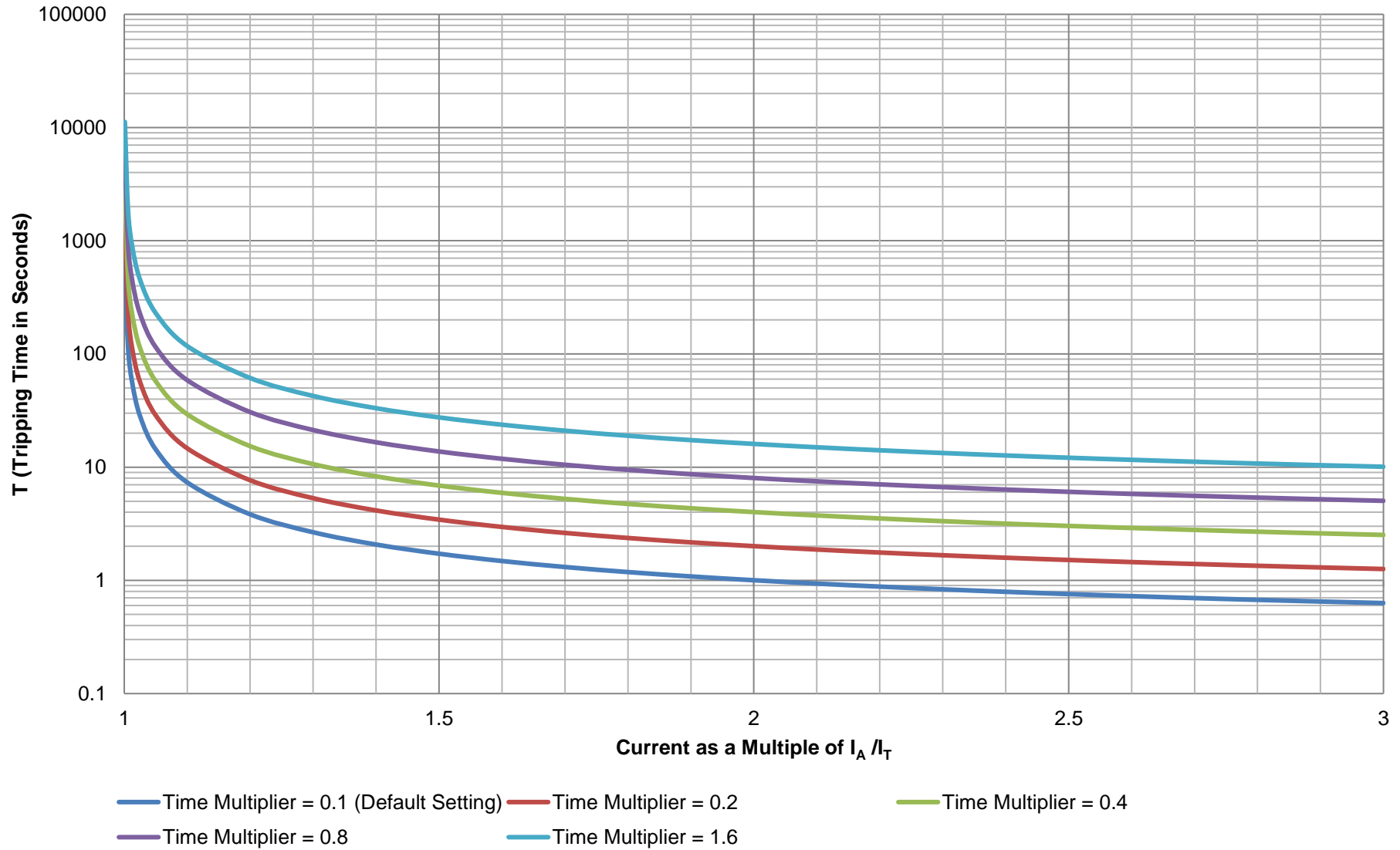

### **2.7.6.2.1 DEFAULT CURRENT PROTECTION TRIPPING CHARACTERISTICS**

The graph on the following page shows the default settings for the IDMT tripping curves for the *Over Current*, *Short Circuit* and *Earth Fault* protections.

The default setting for the *Over Current* alarm allows for an overload of an alternator to the limits of the *Typical Brushless Alternator* whereby 110% overload is permitted for 1 hour or 200% overload is permitted for 36 seconds. In an over current situation the alternator begins to overheat. The aim of the *Over Current IDMT Alarm* is to prevent the windings being overloaded (heated) too much. The amount of time that the alternator can be safely overloaded is governed by how high the overload condition is.

The default setting for the *Short Circuit* alarm allows for an alternator to supply a high current caused by a genuine short circuit or an inrush current of a motor/transformer. Whereby 300% overload is permitted for 0.17 seconds or 600% overload is permitted for 0.06 seconds. In a short circuit situation the alternator begins to overheat to the point the insulation breaks down, potentially causing a fire. The aim of the *Short Circuit IDMT Alarm* is to prevent the insulation from melting due to excessive heat. The amount of time that the alternator can be safely in a short circuit condition is governed by the alternator's construction.

The default setting for the *Earth Fault* alarm allows for an alternator to supply a fault current caused by an imbalanced load, a high impedance short to earth or motor drives. Whereby anything less than 10% is considered normal (caused by imbalanced loads) and permitted, 12% fault current is permitted for 3.83 second or 20% fault current is permitted for 1 second.

## DSE Default Configuratuion of Over Current, Short Circuit & Earth Fault IDMT Alarm Curves

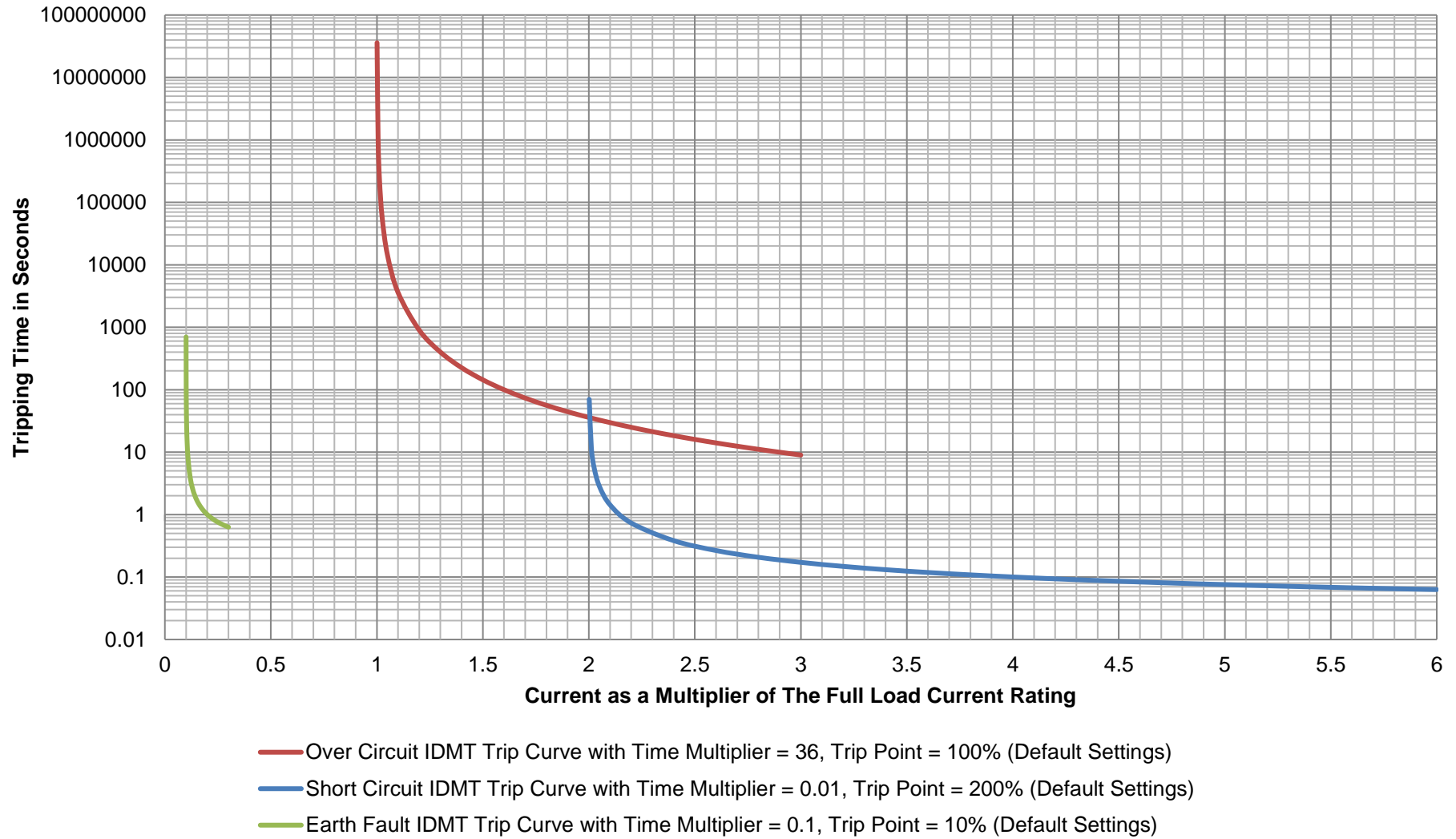

## 2.7.7 GENERATOR POWER

The *Generator Power* section is subdivided into smaller sections. Select the required section with the mouse.

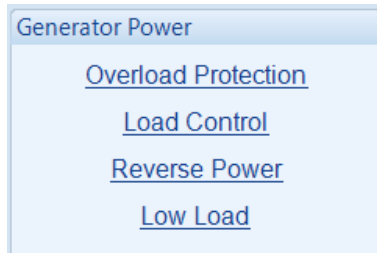

### 2.7.7.1 OVERLOAD PROTECTION

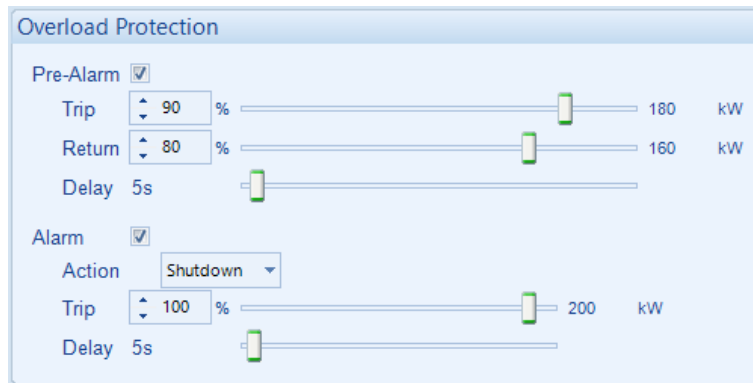

Parameter	Description
Overload Protection Pre-Alarm	<input type="checkbox"/> = Overload Protection Pre-Alarm is disabled. <input checked="" type="checkbox"/> = The <i>kW Overload Warning Alarm</i> activates when the kW level exceeds the <i>Trip</i> setting for longer than the configured <i>Delay</i> time. The <i>kW Overload Warning Alarm</i> de-activates when the kW level falls below the <i>Return</i> setting.
Overload Protection Alarm	<input type="checkbox"/> = Overload Protection Alarm is disabled. <input checked="" type="checkbox"/> = The <i>kW Overload Alarm</i> activates when the kW level exceeds the <i>Trip</i> setting for longer than the configured <i>Delay</i> time.
Action	Select the action for the <i>kW Overload Alarm</i> : <b>Electrical Trip</b> <b>Shutdown</b>

## 2.7.7.2 LOAD CONTROL

### Dummy Load Control

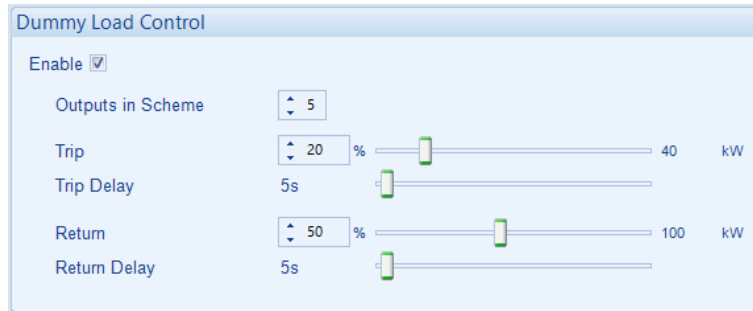

Parameter	Description
Dummy Load Control Enable	Provides control of configurable outputs set to <i>Dummy Load Control</i> . <input type="checkbox"/> = Dummy Load Control is disabled. <input checked="" type="checkbox"/> = The module monitors the load and controls outputs configured to <i>Dummy Load Control (1 to 5)</i>
Outputs in Scheme	The amount of Dummy Load Control outputs that are included in the function.
Trip / Trip Delay	When the load level is below the <i>Trip</i> setting for the duration of the <i>Trip Delay</i> , then the 'next' output configured to <i>Dummy Load Control</i> is activated (max 5)
Return / Return Delay	When the load level rises above the <i>Return</i> level for the duration of the <i>Return Delay</i> , then the 'highest numbered' output configured to <i>Dummy Load Control</i> is de-activated and the timer is reset.

**Load Shedding Control**

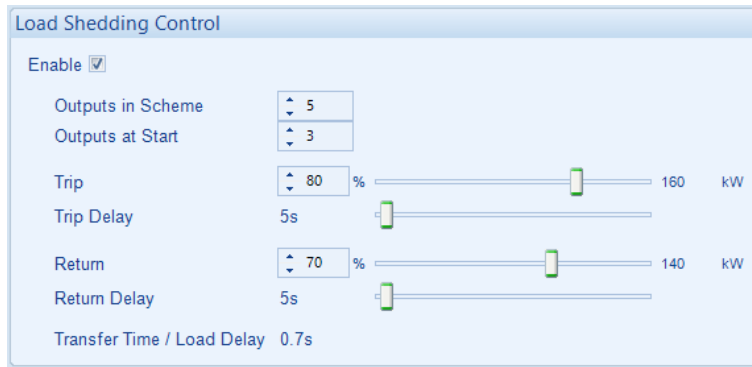

Parameter	Description
Load Shedding Control Enable	Provides control of configurable outputs set to <i>Load Shedding Control</i> . <input type="checkbox"/> = Load Shedding Control is disabled. <input checked="" type="checkbox"/> = The module monitors the load and controls any outputs configured to <i>Load Shedding Control (1 to 5)</i>
Outputs in Scheme	The number of outputs (max 5) that is included in the function.
Outputs at Start	The number of outputs configured to <i>Load Shedding Control 1 to 5</i> that are energised when the set is required to take load. The <i>Transfer Delay / Load Delay</i> timer begins. At the end of this timer, the generator load switch is closed – The generator is placed on load.
Trip / Trip Delay	When the load level is above the <i>Trip</i> setting for the duration of the <i>Trip Delay</i> , then the 'next' output configured to <i>Load Shedding Control</i> is activated (max 5)
Return / Return Delay	When the load level is below the <i>Return</i> setting for the duration of the <i>Return Delay</i> , then the 'highest numbered' output configured to <i>Load Shedding Control</i> is de-activated and the timer is reset.
Transfer Time / Load Delay	The time between closing the <i>Load Shedding Control</i> outputs ( <i>Outputs at Start</i> ) and closing the generator load switching device.

### 2.7.7.3 REVERSE POWER

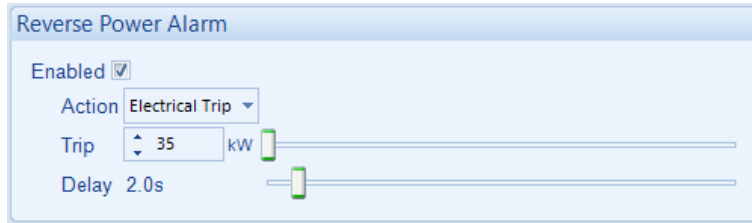

Parameter	Description
Reverse Power Alarm Enable IEEE 37.2 – 32 Directional Power Relay	<input type="checkbox"/> = Generator Reverse Power Alarm is disabled. <input checked="" type="checkbox"/> = The Generator Reverse Power Alarm activates when the reverse power exceeds the Reverse Power Trip setting longer than the configured Delay time. This is used to protect against back feed from electric motors when mechanically overpowered.
Action	Select the action for the Reverse Power Alarm: <b>Electrical Trip</b> <b>Indication</b> <b>Shutdown</b> <b>Warning</b>

### 2.7.7.4 LOW LOAD

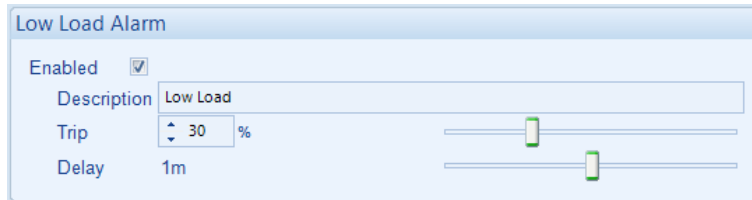

Parameter	Description
Low Load Alarm Enable	<input type="checkbox"/> = Low Load Alarm is disabled. <input checked="" type="checkbox"/> = The Low Load Alarm activates when the generator power drops below the configured Trip setting longer than the configured Delay time. This is used to prevent the engine from running at very low load levels.
Description	Enter the LCD text that shows up on the display when this alarm activates
Trip	Set the percentage of total power at which the Low Load Alarm is activated
Delay	Set the amount of time before the Low Load Alarm activates.

## 2.7.8 MAINS DECOUPLING

**NOTE:** The *Mains Decoupling* protections only have effect when a digital input is configured for *Mains Parallel Mode* instructing the module to operate in fixed export mode with the utility supply. For more information on this application, refer to DSE Publication: *056-054 DSE8x10 in Fixed Export (Base Load)* which is found on our website: [www.deepseaelectronics.com](http://www.deepseaelectronics.com)

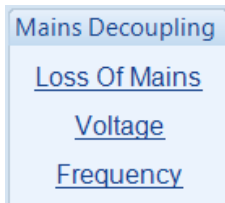

The *Mains Decoupling* section is subdivided into smaller sections. Select the required section with the mouse.

The controller includes “Mains decoupling” detection to be used with generating sets paralleling with the Mains (utility) supply.

When the generator set is in parallel with the Mains supply it is important that failure of the Mains is detected as soon as possible otherwise problems arise. It is not possible to simply monitor the Mains voltage and frequency as the sensing of this is now being fed by the generator itself!

Because of this and other possible dangerous situations, the power supply companies impose regulations when generators are in parallel. This is to detect Mains failure during parallel operation and to remove the generator from the grid in this situation.

Failure to detect and act upon loss of Mains supply when in parallel leads to the following effects:

- The generator feeds the site load and attempts to feed the load of the grid. Depending upon the generator size and the location of the network fault, this causes problems to the generator in terms of capacity and stability.
- If the generator is able to supply the load, Engineers working on the supposedly dead network would be in fact working on live cables, supplied by the generator set. This is potentially fatal.
- When the Mains supply is reconnected and the generator is still connected to the grid, the network would be connected to a generator not synchronised with it, with damaging results (mechanical failure, rotating diode failure, overloaded cables, pole slip etc)

### 2.7.8.1 LOSS OF MAINS

#### R.O.C.O.F. Alarm



Parameter	Function
R.O.C.O.F. Alarm Enable IEEE 37.2 - 81 Frequency relay	<p><input type="checkbox"/> = R.O.C.O.F. protection is disabled</p> <p><input checked="" type="checkbox"/> = R.O.C.O.F. protection is enabled. The <i>R.O.C.O.F. Alarm</i> activates when the generator/Mains frequency changes faster than the configured <i>Trip</i> setting. The <i>R.O.C.O.F. Alarm</i> is only enabled when the generator is in parallel with the Mains supply and an input configured for <i>Mains Parallel Mode</i> is active.</p> <p>R.O.C.O.F. detection senses sudden, fast changes in the frequency of the waveform. During the failure of the Mains supply when in parallel with the generator, the frequency changes faster than is usual by either the on load generator, or by the Mains supply.</p>

#### Vector Shift Alarm

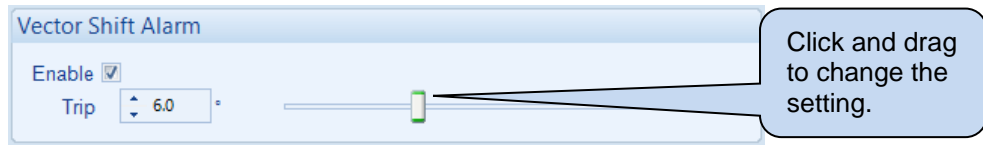

Parameter	Function
Vector Shift	<p><input type="checkbox"/> = Vector Shift protection is disabled</p> <p><input checked="" type="checkbox"/> = Vector Shift protection is enabled. The <i>Vector Shift Alarm</i> activates when the generator/Mains voltage vector changes by more than the <i>Trip</i> setting. The <i>Vector Shift Alarm</i> is only enabled when the generator is in parallel with the Mains supply and an input configured for <i>Mains Parallel Mode</i> is active.</p> <p>Vector Shift detection measures the length of each cycle of the voltage wave. When the Mains fails in parallel with the generator, the sudden change in load creates a change in the length of the cycle length.</p>

## 2.7.8.2 VOLTAGE ALARMS

### Limits

Limits  
 Impose IEEE 1547 Limits No Limits

Parameter	Description
Impose IEEE 1547 Limits	<p><b>NOTE: Category Limits are only applicable for 60Hz nominal frequency.</b></p> <p>Limit the Mains Decoupling Alarms as imposed by IEEE rules, options are:</p> <p><b>No Limits</b>  <b>Category I Limit</b>  <b>Category II Limit</b>  <b>Category III Limit</b></p>

### Under Voltage Alarms

Under Voltage Alarms

Stage 2 Enable  Trip 50 V PhN 21.7% 50V PhN Delay 0.0 s

Stage 1 Enable  Trip 184 V PhN 80.0% 184V PhN Delay 2.5 s

Parameter	Description
Mains Under Voltage, Stage 1 to Stage 2 <a href="#">IEEE 37.2 - 27AC Undervoltage Relay</a>	<p>These are '2 stage' alarms. Stage 1 allows for a delayed operation should the voltage stray by a small amount. Stage 2 allows for a faster trip should the voltage change by a larger amount.</p> <p><input type="checkbox"/> = Mains Under Voltage does NOT give an alarm  <input checked="" type="checkbox"/> = Mains Under Voltage protection is enabled when the generator is in parallel with the Mains supply and an input configured for <i>Mains Parallel Mode</i> is active. The alarm activates when the Mains voltage falls below the configured <i>Under Voltage Alarm Trip</i> value for longer than the <i>Delay</i>. The <i>Under Voltage Alarm Trip</i> value is adjustable to suit user requirements.</p>

### Nominal Voltage

Nominal Voltage

230 V PhN 100.0% 230V PhN

Parameter	Description
Mains Nominal Voltage	The <i>Mains Nominal Voltage</i> is locked to the same configuration as the <i>Generator Nominal Voltage</i> . This section is displayed for clarification purposes only.

**Over Voltage Alarms**

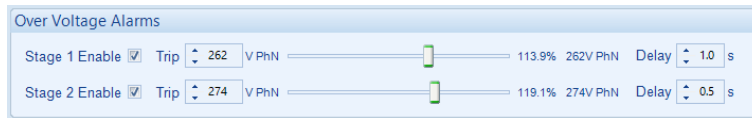

Parameter	Description
Mains Over Voltage, Stage 1 to Stage 2 IEEE 37.2 - 59AC Overvoltage Relay	<p>These are '2 stage' alarms.                      Stage 1 allows for a delayed operation should the voltage stray by a small amount.                      Stage 2 allows for a faster trip should the voltage change by a larger amount.</p> <p><input type="checkbox"/> = Mains Over Voltage does NOT give an alarm  <input checked="" type="checkbox"/> = Mains Over Voltage protection is enabled when the generator is in parallel with the Mains supply and an input configured for <i>Mains Parallel Mode</i> is active. The alarm activates when the Mains voltage rises above the configured <i>Over Voltage Alarm Trip</i> value for longer than the <i>Delay</i>. The <i>Over Voltage Alarm Trip</i> value is adjustable to suit user requirements.</p>

### 2.7.8.3 FREQUENCY

#### Limits

Limits

Impose IEEE 1547 Limits No Limits

Parameter	Description
Impose IEEE 1547 Limits	<p><b>NOTE: Category Limits are only applicable for 60Hz nominal frequency.</b></p> <p>The <i>Limits</i> is locked to the same configuration as in the <i>Mains Decoupling Voltage</i> section's <i>Limits</i>. This section is displayed for clarification purposes only.</p>

#### Under Frequency Alarms

Under Frequency Alarms

Stage 2 Enable  Trip 47.00 Hz 94.0% Delay 0.50 s

Stage 1 Enable  Trip 47.50 Hz 95.0% Delay 20.00 s

Parameter	Description
Mains Under Frequency, Stage 1 to Stage 2 IEEE 37.2 – 81L Frequency Relay	<p>These are '2 stage' alarms.</p> <p>Stage 1 allows for a delayed operation should the frequency stray by a small amount.</p> <p>Stage 2 allows for a faster trip should the frequency change by a larger amount.</p> <p><input type="checkbox"/> = Mains Under Frequency does NOT give an alarm</p> <p><input checked="" type="checkbox"/> = Mains Under Frequency protection is enabled when the generator is in parallel with the Mains supply and an input configured for <i>Mains Parallel Mode</i> is active. The alarm activates when the Mains frequency falls below the configured <i>Under Frequency Alarm Trip</i> value for longer than the <i>Delay</i>. The <i>Under Frequency Alarm Trip</i> value is adjustable to suit user requirements.</p>

#### Nominal Frequency

Nominal Frequency

50.0 Hz 100.0%

Parameter	Description
Mains Nominal Frequency	The <i>Mains Nominal Frequency</i> is locked to the same configuration as the <i>Generator Nominal Frequency</i> . This section is displayed for clarification purposes only.

**Over Frequency Alarms**

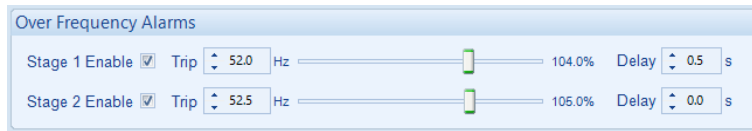

Parameter	Description
Mains Over Frequency, Stage 1 to Stage 5 IEEE 37.2 – 81H Frequency Relay	<p>These are '2 stage' alarms.</p> <p>Stage 1 allows for a delayed operation should the frequency stray by a small amount.</p> <p>Stage 2 allows for a faster trip should the frequency change by a larger amount.</p> <p><input type="checkbox"/> = Mains Over Frequency does NOT give an alarm</p> <p><input checked="" type="checkbox"/> = Mains Over Frequency protection is enabled when the generator is in parallel with the Mains supply and an input configured for <i>Mains Parallel Mode</i> is active. The alarm activates when the Mains voltage rises above the configured <i>Over Frequency Alarm Trip</i> value for longer than the <i>Delay</i>. The <i>Over Frequency Alarm Trip</i> value is adjustable to suit user requirements.</p>

## 2.7.9 SYNCHRONISING

The *Synchronising* section is subdivided into smaller sections. Select the required section with the mouse.



### 2.7.9.1 SYNC OPTIONS

#### Options

Options

Enable Synchronising

Persistent Governor Output

Persistent AVR Output

Parameter	Description
Enable Synchronising	<input checked="" type="checkbox"/> = The module automatically detects the need to synchronise depending upon the state of <i>Mains Parallel Mode</i> input (if configured) and automatic detection of additional generators using the MultiSet Communications (MSC) link.
Persistent Governor Output	Configures the action to take when transitioning from <i>Synchronising</i> to <i>Load Sharing</i> (at the point of closing the load switch device into parallel with another supply). <input type="checkbox"/> = Analogue GOV output resets to <i>Centre</i> (SW setting) when the load switch device is closed. <input checked="" type="checkbox"/> = Analogue GOV output retains the value achieved during the synchronising process.
Persistent AVR Output	Configures the action to take when transitioning from <i>Synchronising</i> to <i>Load Sharing</i> (at the point of closing the load switch device into parallel with another supply). <input type="checkbox"/> = Analogue AVR output resets to <i>Centre</i> (SW setting) when the load switch device is closed. <input checked="" type="checkbox"/> = Analogue AVR output retains the value achieved during the synchronising process.

**Governor**

Governor	
Interface	Internal Analogue
Output Reversed	<input type="checkbox"/>
Action	Adjust To Nominal Frequency

Parameter	Description
Governor Interface	<p><b>NOTE:</b> When <i>Internal Relays</i> is selected, it is necessary to configure two of the module digital outputs to provide the required <i>Speed Raise</i> and <i>Speed Lower</i> signals.</p> <p><b>Internal Analogue:</b> The module uses a CANbus message or it's a 0 V to 10 V output to interface with the engine governor to enable frequency and kW control.</p> <p><b>Internal Relays:</b> The module use's is digital outputs (configured for <i>Speed Raise</i> and <i>Speed Lower</i>) to interface with the engine governor to enable frequency and kW control.</p> <p><b>None:</b> The module does not interface with the engine governor, frequency and kW control is achieved using external 3<sup>rd</sup> party equipment.</p>
Governor Output Reversed	<p><b>NOTE:</b> Only available when internal analogue is selected. This allows the module to interface with a greater diversity of Governors.</p> <p><input type="checkbox"/> = Lower analogue output voltage equates to lower engine speed.  <input checked="" type="checkbox"/> = Lower analogue output voltage equates to higher engine speed.</p>
Adjust to Nominal Frequency	<p><b>NOTE:</b> This determines the modules frequency control when the generator is running on load and not in parallel.</p> <p><b>Adjust to Centre Point:</b> When the generator's switchgear has closed, the generator's frequency is pre-determined by <i>SW1</i> setting for the governor. Refer to section entitled <i>Governor / AVR Interface</i> elsewhere in this document for further information about the <i>SW1</i> setting.</p> <p><b>Adjust to Nominal:</b> When the generator's switchgear has closed, the generator's frequency is pre-determined by <i>Nominal Frequency</i> setting for the generator. Refer to section entitled <i>Generator Frequency</i> elsewhere in this document for further information about the <i>Nominal Frequency</i> setting.</p> <p><b>None:</b> When the generator's switchgear has closed, the generator's frequency is not controlled by the module. The frequency control is achieved using external 3<sup>rd</sup> party equipment.</p>

**AVR**

AVR	
Output	Internal Analogue
Output Reversed	<input type="checkbox"/>
Action	Adjust To Nominal Voltage

Parameter	Description
AVR Interface	<p><b>▲ NOTE: When <i>Internal Relays</i> is selected, it is necessary to configure two of the module digital outputs to provide the required <i>Voltage Raise</i> and <i>Voltage Lower</i> signals.</b></p> <p><b><i>Internal Analogue:</i></b> The module uses its 0 V to 10 V AVR output to interface with generator's AVR to enable voltage and kvar control.</p> <p><b><i>Internal Relays:</i></b> The module use's is digital outputs (configured for <i>Voltage Raise</i> and <i>Voltage Lower</i>) to interface with the generator's AVR to enable voltage and kvar control.</p> <p><b><i>None:</i></b> The module does not interface with the generator's AVR, voltage and kvar control is achieved using external 3<sup>rd</sup> party equipment.</p>
AVR Output Reversed	<p><b>▲ NOTE: Only available when internal analogue is selected. This allows the module to interface with a greater diversity of AVRs.</b></p> <p><input type="checkbox"/> = Lower analogue output voltage equates to lower alternator voltage.  <input checked="" type="checkbox"/> = Lower analogue output voltage equates to higher alternator voltage.</p>
Adjust to Nominal Voltage	<p><b>▲ NOTE: This setting determines the voltage control when the generator is running on load and not in parallel only.</b></p> <p><b><i>Adjust to Centre Point:</i></b> When the generator's switchgear has closed, the generator's voltage is pre-determined by <i>SW1</i> setting for the AVR. Refer to section entitled <i>Governor / AVR Interface</i> elsewhere in this document for further information about the <i>SW1</i> setting.</p> <p><b><i>Adjust to Nominal:</i></b> When the generator's switchgear has closed, the generator's voltage is pre-determined by <i>Nominal Voltage</i> setting for the generator. Refer to section entitled <i>Generator Voltage</i> elsewhere in this document for further information about the <i>Nominal Voltage</i> setting.</p> <p><b><i>None:</i></b> When the generator's switchgear has closed, the generator's voltage is not controlled by the module. The voltage control is achieved using external 3<sup>rd</sup> party equipment.</p>

**MSC Compatibility**

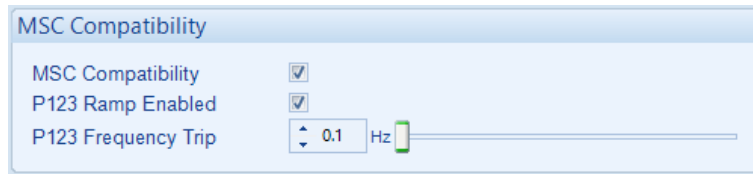

Parameter	Description
MSC Compatibility	<p><input type="checkbox"/> = The DSE8610 MKII is not able to communicate with the DSEP123, DSE55xx and DSE75xx series modules on the MSC Link</p> <p><input checked="" type="checkbox"/> = Communication with DSEP123, DSE55xx and DSE75xx series modules is possible. The maximum number of DSExx10 controllers is reduced to 16 and the maximum number of DSExx60 controllers is reduced to 8.</p>
P123 Ramp Enabled	<p><b>NOTE:</b> As DSE123 is a legacy device, <i>MSC Compatibility</i> must be selected to enable selection of <i>P123 Ramp Enabled</i>.</p> <p><input type="checkbox"/> = The MSC link is used for ramping and load sharing.</p> <p><input checked="" type="checkbox"/> = The module is connected to a DSE123 to convert the MSC link to interface with Analogue Load Share lines.</p>
P123 Frequency Trip	<p><b>NOTE:</b> Only Available when P123 Ramp option is enabled</p> <p>As the DSE123 is in use (meaning MSC link features are not available), this function is used to detect the generator being the last one running (no other generators are on the bus). If the frequency changes by this amount when ramping down, the module opens the generator breaker.</p>

## 2.7.9.2 CHECK SYNC

### Dead Bus

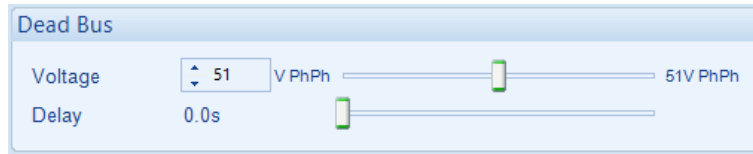

*Dead Bus* detection is used in two scenarios:

- If the bus is considered to be dead, controller(s) communicate over the MSC link to determine which one closes to the dead bus. If the bus is live, synchronisation takes place before the load switch is closed.
- Upon closing the load switch, the bus must be seen to be 'not dead' a short time later.

Parameter	Description
Voltage	The voltage below which the bus is assumed to be 'dead'.
Delay	When the load switch is closed, the bus voltage is measured a short time later, determined by <i>Delay</i> . Should the bus voltage be below the level of the <i>Dead Bus Voltage</i> setting, <i>Bus Not Live</i> electrical trip alarm is raised.

### Check Sync

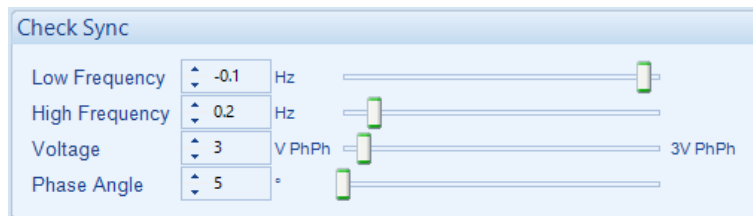

During the synchronising process, the controller adjusts the frequency and voltage of the generator to closely match the existing bus. Typically the oncoming set is adjusted to be 0.1 Hz faster than the existing supply, this causes the phase of the two supplies to change continuously.

Before the breaker is closed, the following configurable conditions must be met.

Parameter	Description
Low Frequency	The difference between the two supplies frequencies must be between the <i>Check Sync Low Frequency</i> and <i>Check Sync High Frequency</i>
Voltage	The difference between the two supplies voltages must be equal to or below the <i>Check Sync Voltage</i>
Phase Angle	The phase of the two supplies must be equal to or below the <i>Check Sync Phase Angle</i>

**Fail to Sync Alarm**

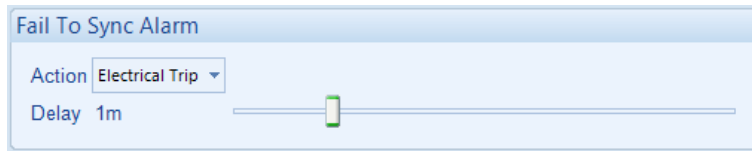

Used to detect that the synchronising process is taking a long time. This occurs when changes in the load are making the set control difficult due to changes in voltage and frequency.

Parameter	Description
Action	Determines the action to take upon a <i>Fail to Sync</i> . <b>Electrical Trip:</b> The set is stopped. In a <i>Load Demand</i> scheme, other generators start if available. <b>Indication:</b> The set continues to synchronise and no alarm is raised. This is used for internal use, such as in the <i>PLC Logic</i> or <i>Virtual LEDs</i> . <b>Warning:</b> The set continues to attempt to synchronise.
Delay	The time to allow for successful synchronisation to take place. If the process continues longer than <i>Delay</i> , the <i>Action</i> above is taken.

### 2.7.9.3 MSC LINK



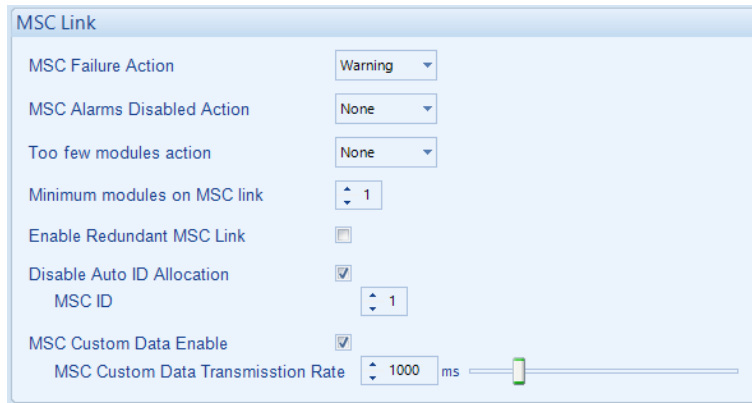

**NOTE:** The MSC Link Alarms are disabled by a digital input configured to *MSC Alarms Inhibit* if required.

**NOTE:** When the MSC2 (*Redundant MSC Link*) is enabled but the MSC1 is not wired, the DSE module issues an *MSC Alarm* preventing communication over the MSC2.



Parameter	Description
MSC Failure Action	<p>Action upon MSC Link Failure:</p> <p><b>Electrical Trip:</b> The breaker is opened immediately and the stopping sequence is initiated.</p> <p><b>Indication:</b> The set continues to run and no alarm is raised. This is used for internal use, such as in the <i>PLC Logic</i> or <i>Virtual LEDs</i>.</p> <p><b>Warning:</b> The set continues to run and a warning alarm is activated.</p>
MSC Alarms Disabled Action	<p>Action to take when the MSC alarm is disabled by a digital input:</p> <p><b>Indication:</b> The set continues to run and no alarm is raised. This is used for internal use, such as in the <i>PLC Logic</i> or <i>Virtual LEDs</i>.</p> <p><b>None:</b> Alarm is disabled.</p> <p><b>Warning:</b> The set continues to run and a warning alarm is activated.</p>
Too Few Modules Action	<p>Action to take when the number of modules active on the MSC link is lower than the <i>Minimum Modules on MSC link</i> setting</p> <p><b>Electrical Trip:</b> The breaker is opened immediately and the stopping sequence is initiated.</p> <p><b>Indication:</b> The set continues to run and no alarm is raised. This is used for internal use, such as in the <i>PLC Logic</i> or <i>Virtual LEDs</i>.</p> <p><b>None:</b> Alarm is disabled.</p> <p><b>Warning:</b> The set continues to run and a warning alarm is activated.</p>

Parameters continued overleaf...

Parameter	Description
Minimum Modules On MSC Link	Set the minimum number of modules on the MSC before the <i>Too Few Modules</i> alarm is activated.
Enable Redundant MSC Link	 <b>NOTE: When required, this option must be enabled on all DSE8xxx MKII modules connected on the MSC Link.</b>
	 <b>NOTE: When the <i>Redundant MSC Link</i> is enabled, the <i>PLC MSC Data</i> is no longer available.</b>
	<input type="checkbox"/> = Only one Multi-Set Comms (MSC) Link is active. <input checked="" type="checkbox"/> = This activates the second (redundant) Multi-Set Comms (MSC) Link, allowing for communications redundancy between the controllers.
Disable Auto ID Allocation	 <b>NOTE: When required, this option must be enabled on all DSE8xxx MKII modules connected on the MSC Link.</b>
	<input type="checkbox"/> = The MSC system assigns the MSC ID automatically when the DSE module powered over the MSC network. <input checked="" type="checkbox"/> = The MSC system does not assign the MSC ID automatically when the DSE module is powered up, instead the DSE module uses the <i>MSC ID</i> number configured in this section.
MSC Custom Data Enable	 <b>NOTE: It is not possible to Write a configuration file to the module if the <i>Redundant MSC Link</i> is enabled and <i>PLC MSC Data</i> is being transmitted over the MSC.</b>
	 <b>NOTE: For details on how to configure the <i>PLC MSC Data</i>, refer to DSE Publication: <i>057-314 Advanced PLC Software Manual</i> which is found on our website: <a href="http://www.deepseaelectronics.com">www.deepseaelectronics.com</a></b>
	<input type="checkbox"/> = The <i>MSC Custom Data</i> is disabled and there are no <i>PLC MSC</i> items transmitted over the MSC Link <input checked="" type="checkbox"/> = The <i>MSC Custom Data</i> is enabled, and the <i>PLC MSC Data</i> is transmitted on the MSC Link.
MSC Custom Data Transmission Rate	This option is available when the <i>MSC Custom Data</i> is enabled. Select the rate at which the <i>PLC MSC Data</i> is transmitted over the MSC Link.

#### 2.7.9.4 LOAD CONTROL

**NOTE:** The *Minimum Load Level* and *Maximum Load Level* are configured within the SCADA section. For further details, refer to section entitled *Load Levels* contained within the SCADA section elsewhere within this document.

When any of the following *Load Control* modes are selected, the controller performs a 'soft' load transfer when taking or removing load.

Upon generator's switchgear closing, the module controls the generators power production starting from the *Minimum Load Level* setting. Load is then applied to the generator at the configured *Ramp Up Rate*. The ramping continues until generator is producing an equal percentage of full load power as the other generators on the bus, or to the *Maximum Load Level* when running in *Mains Parallel Mode*.

When a paralleled generator leaves the bus, the load is ramped down to the *Minimum Load Level* at the configured *Ramp Down Rate*. The generator's switchgear is opened once the *Minimum Load Level* has been attained, removing the generator from the bus.

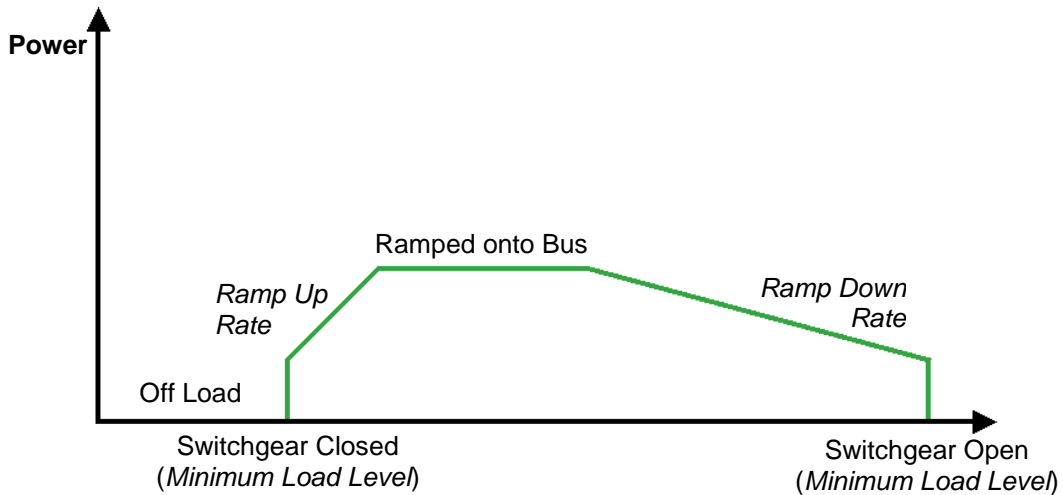

'Soft' load transfers of this type have many benefits, the most obvious are:

- When the generator is removed from the bus, other sets in the system are not suddenly loaded with the load that was being supplied by the generator being removed. Instead, the load is slowly ramped, allowing time for the remaining sets to take up their share of the load.
- Opening of the load switch occurs at a much lower load level, helping to reduce arcing of the contacts.

**Load Options**

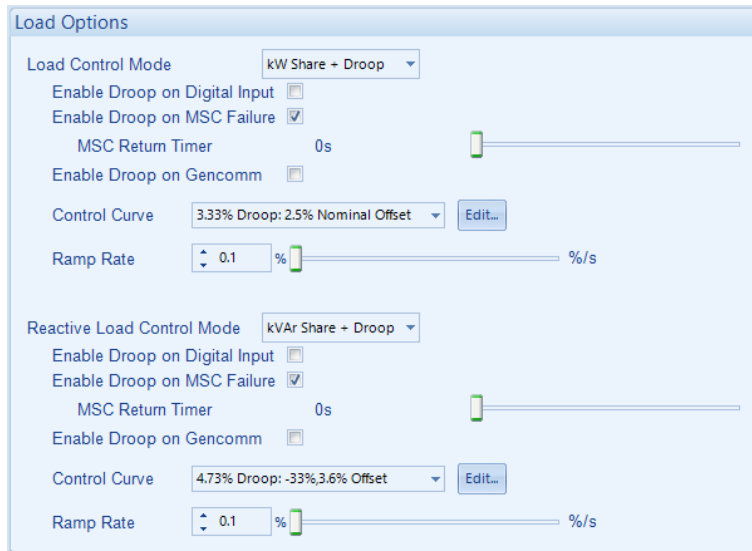





Parameter	Description
Load Control Mode IEEE 37.2 -90 Regulating device	<p><b>NOTE:</b> The module automatically switches from <i>kW Load Control</i> mode to <i>kW Power Control</i> mode when an input configured for <i>Mains Parallel Mode</i> is active. Refer to section entitled <i>Power Control</i> elsewhere in is document for further details.</p> <p><b>Droop:</b> The module synchronises the generator to the generator bus and controls the kW load sharing using droop. Droop based kW load sharing ensures that the generators produce an equal percentage of kW by varying frequency. Droop based kW load sharing is possible between generators that are not fitted with DSE modules and have frequency droop enabled.</p> <p><b>kW Share:</b> The module synchronises the generator to the generator bus and controls the kW load sharing isochronously between DSE modules. Isochronous kW load sharing ensures that the generators produce an equal percentage of kW whilst maintaining nominal frequency. Isochronous kW load sharing is only possible when using the MSC link between DSE modules.</p> <p><b>kW Share + Droop:</b> The module synchronises the generator to the generator bus and controls the kW load sharing isochronously between DSE modules. The kW load control is switched from isochronous to droop either by activating a digital input, MSC Failure or Gencomm request based upon user configuration.</p> <p><b>None:</b> The module synchronises the generator to the generator bus but once in parallel, does not actively control the kW load sharing. This is left to external 3<sup>rd</sup> party devices such as external load share controller or droop configured on the engine governor.</p>

Parameter descriptions are continued overleaf...

Parameter	Description
Enable Droop on Digital Input	<p><b>▲ NOTE: Only available when <i>Load Control Mode</i> is configured as <i>kW Share + Droop</i>.</b></p> <p><input type="checkbox"/> = It is not possible to switch from kW isochronous to droop load sharing by digital input.</p> <p><input checked="" type="checkbox"/> = It is possible to switch from kW isochronous to droop load sharing by digital input.</p>
Enable Droop on MSC Failure	<p><b>▲ NOTE: Only available when <i>Load Control Mode</i> is configured as <i>kW Share + Droop</i>.</b></p> <p><input type="checkbox"/> = It is not possible to switch kW isochronous to droop load sharing by when the MSC link fails.</p> <p><input checked="" type="checkbox"/> = The module switches from kW isochronous to droop load sharing when the MSC link fails. The module reverts to kW isochronous load sharing once the MSC link returns for longer than the <i>MSC Return Timer</i>.</p>
Enable Droop on Gencomm	<p><b>▲ NOTE: Only available when <i>Load Control Mode</i> is configured as <i>kW Share + Droop</i>.</b></p> <p><input type="checkbox"/> = It is not possible to switch from kW isochronous to droop load sharing by Gencomm (MODBUS request).</p> <p><input checked="" type="checkbox"/> = It is possible to switch from kW isochronous to droop load sharing by Gencomm (MODBUS request).</p>
Control Curve	<p><b>▲ NOTE: It is advised that all generators in the system have the same droop curve configured to ensure equal percentage of kW load sharing between them.</b></p> <p>Select the required droop curve from a pre-defined list or create a user-defined curve.</p> <p><i>Droop</i> is the percentage of nominal frequency that the generator's frequency decreases by as the load varies from 0 % to 100 % of the kW rating of the generator.</p> <p><i>Nominal Offset</i> is the percentage above/below the nominal frequency in which the droop starts from.</p> <p>A <i>Droop</i> of 5% with a <i>Nominal Offset</i> of 3% on a 50 Hz system would result in the generator running at 51.5 Hz (103% of nominal) at 0 % kW and 49 Hz (98% of nominal) at 100 % kW with a linear change between them.</p>
Ramp Rate	The rate at which the generator kW is ramped onto and off the load when using Droop.

Parameter descriptions are continued overleaf...

Parameter	Description
Reactive Load Control Mode IEEE 37.2 -90 Regulating device	<div style="border: 1px solid black; padding: 5px; margin-bottom: 10px;">  <b>NOTE: Reactive Load Control Mode is forced to None when Load Control Mode set to None.</b> </div> <div style="border: 1px solid black; padding: 5px; margin-bottom: 10px;">  <b>NOTE: The module automatically switches from <i>kvar Load Control</i> mode to <i>kvar Power Control</i> mode when an input configured for <i>Mains Parallel Mode</i> is active. Refer to section entitled <i>Power Control</i> elsewhere in is document for further details.</b> </div> <p><b>Droop:</b> The module synchronises the generator to the generator bus and controls the kvar load sharing using droop. Droop based kvar load sharing ensures that the generators produce an equal percentage of kvar by varying voltage. Droop based kvar load sharing is possible between generators that are not fitted with DSE modules also have voltage droop enabled.</p> <p><b>kvar Fixed Export:</b> The module synchronises the generator to the generator bus and controls the kvar by forcing it to a pre-determined value.</p> <p><b>kvar Share:</b> The module synchronises the generator to the generator bus and controls the kvar load sharing isochronously between DSE modules. Isochronous kvar load sharing ensures that the generators produce an equal percentage of kvar whilst maintaining nominal voltage. Isochronous kvar load sharing is only possible when using the MSC link between DSE modules.</p> <p><b>kvar Share + Droop:</b> The module synchronises the generator to the generator bus and controls the kvar load sharing isochronously between DSE modules. The kvar load control is switched from isochronous to droop either by activating a digital input, MSC Failure or Gencomm request based upon user configuration.</p> <p><b>None:</b> The module synchronises the generator to the generator bus but once in parallel, does not actively control the kvar load sharing. This is left to external 3<sup>rd</sup> party devices such as external load share controller or droop configured on the alternator AVR.</p>
Enable Droop on Digital Input	<div style="border: 1px solid black; padding: 5px; margin-bottom: 10px;">  <b>NOTE: Only available when Load Control Mode is configured as <i>kvar Share + Droop</i>.</b> </div> <p><input type="checkbox"/> = It is not possible to switch from kvar isochronous to droop load sharing by digital input.</p> <p><input checked="" type="checkbox"/> = It is possible to switch from kvar isochronous to droop load sharing by digital input.</p>
Enable Droop on MSC Failure	<div style="border: 1px solid black; padding: 5px; margin-bottom: 10px;">  <b>NOTE: Only available when Load Control Mode is configured as <i>kvar Share + Droop</i>.</b> </div> <p><input type="checkbox"/> = It is not possible to switch kvar isochronous to droop load sharing by when the MSC link fails.</p> <p><input checked="" type="checkbox"/> = The module switches from kvar isochronous to droop load sharing when the MSC link fails. The module reverts back to kvar isochronous load sharing once the MSC link returns for longer than the <i>MSC Return Timer</i>.</p>

Parameter descriptions are continued overleaf...

Parameter	Description
Enable Droop on Gencomm	<p><b>▲ NOTE: Only available when <i>Load Control Mode</i> is configured as <i>kvar Share + Droop</i>.</b></p> <p><input type="checkbox"/> = It is not possible to switch from kvar isochronous to droop load sharing by Gencomm (MODBUS request).</p> <p><input checked="" type="checkbox"/> = It is possible to switch from kvar isochronous to droop load sharing by Gencomm (MODBUS request).</p>
Control Curve	<p><b>▲ NOTE: It is advised that all generators in the system have the same droop curve configured to ensure equal percentage of kvar load sharing between them.</b></p> <p>Select the required droop curve from a pre-defined list or create a user-defined curve.</p> <p><i>Droop</i> is the percentage of nominal voltage that the generator's frequency decreases by as the load varies from 0 % to 100 % of the kvar rating of the generator.</p> <p><i>Nominal Offset</i> is the percentage above/below the nominal voltage in which the droop starts from.</p> <p>A <i>Droop</i> of 5% with a <i>Nominal Offset</i> of 3% on a 400 V system would result in the generator running at 412 V (103% of nominal) at 0 % kvar and 392 V (98% of nominal) at 100 % kvar with a linear change between them.</p>
Ramp Rate	The rate at which the generator kvar is ramped onto and off the load when using Droop.

**Load Share Ramp**

Load Share Ramp

Ramp Up Rate  %

Ramp Down Rate  %

Ramp Off Load 20s

Parameter	Description
Ramp Up Rate	<p><b>▲ NOTE:</b> The set initially takes load at the level set by the <i>Minimum Load Level</i> and then increases its load share at this rate until either:</p> <ul style="list-style-type: none"> <li>• All the sets have an equal share of the load</li> <li>• The generated power is equal to the setting for <i>Load Parallel Power</i></li> </ul> <p>The rate at which the generator is ramped onto the load when not running in droop.</p>
Ramp Down Rate	<p><b>▲ NOTE:</b> When the set is unloaded, it ramps down at this rate from the current load level to the level set by the <i>Minimum Load Level</i> before being removed from the bus.</p> <p>The rate at which the generator is ramped off the load when not running in droop.</p>
Ramp Off Load	<p>This is to set a time limit to the ramp down process, and it is useful when the engine response is slow or is not capable to ramp off the load.</p> <p>The <i>Ramp Off Load</i> timer starts when the generator begins to ramp down. When this timer is expired the breaker opens regardless of the actual power.</p> <p>It is possible to set the ramp rate slower than this time, so the breaker opens prior to the ramp finishes.</p>

## New Load Demand Scheme

**NOTE:** The V6 software MSC is not compatible with the previous module versions. For more information contact DSE Technical Support [support@deepseaelectronics.com](mailto:support@deepseaelectronics.com)

The module is included in the *Load Demand Scheme* by activating a digital input configured as *Remote Start on Load Demand*. Every DSExx10 module connected on the MSC link which is required to run in the *Load Demand Scheme* must have a digital input configured for *Remote Start on Load Demand* and it be activate. Having this input on each DSExx10 enables a specific generator to be taken out of the *Load Demand Scheme* for service for maintenance (by de-activating the input) whilst allowing the remainder of the system to operate.

Upon activation of the *Remote Start on Load Demand* input, all the generators in the system start. The first generator to become available closes onto the dead bus, communicating with the other generators to instruct them to synchronise onto the now live bus, before closing in parallel. If too much generator capacity is available to supply the load, the generators that are not required begin their *Return Delay* timers, after which they will ramp off the bus and stop.

Whilst one or more generators are already available in *Load Demand Scheme*, it may be required to make all the generators in the system available to provide power to the load. For instance, this may be necessary prior to switching on a large load that the currently available generators are not able to supply. To provide this function, a digital input on each DSExx10 module in the system must be configured to *Remote Start on Load*. Activating this input causes DSExx10 module to start its generator, synchronise with the bus, and close in parallel.

The generators continue to provide power until the *Remote Start on Load* input is de-activated. Providing the *Remote Start on Load Demand* input is still active on all the DSExx10 modules, the *Load Demand Scheme* ramps the un-required generators off the bus, depending upon the total load level.

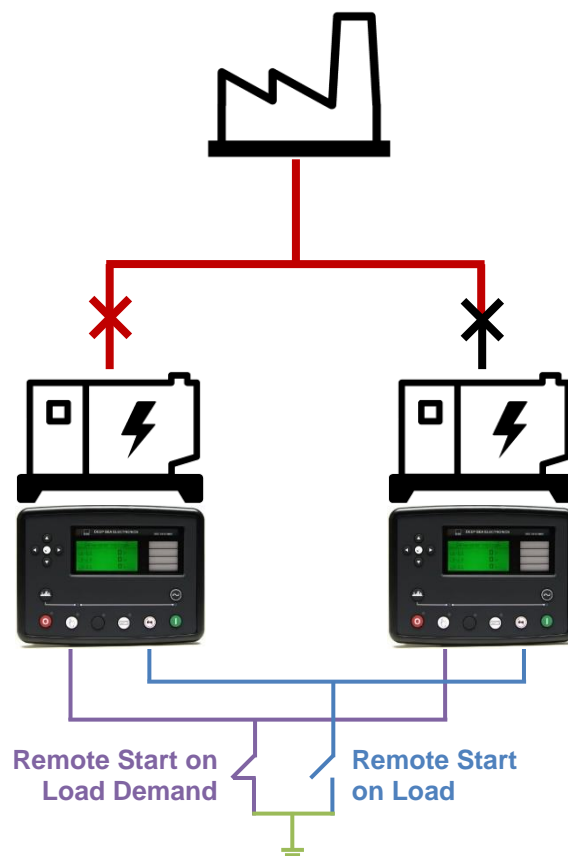

**NOTE:** The V6 software MSC is not compatible with the previous module versions. For more information contact DSE Technical Support [support@deepseaelectronics.com](mailto:support@deepseaelectronics.com)

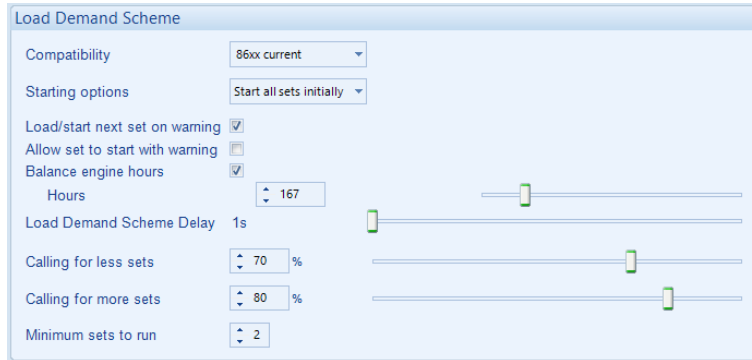

Parameter	Description
Compatibility	<p><b>NOTE:</b> When “86xx up to v5.1” is selected, the <i>Generator De-Rate</i> option is no longer applied, and the <i>PLC MSC Data</i> is no longer available.</p> <p>Select the required <i>Load Demand Scheme</i> compatibility. This is useful when adding a new module to an existing DSE86xx system without the need to upgrade the existing controllers’ software version.</p> <p><b>86xx current:</b> <i>Load Demand Scheme</i> compatible with module versions 6 or later.</p> <p><b>86xx up to v5.1:</b> <i>Load Demand Scheme</i> compatible with module versions 1 up to 5.1</p> <p><b>Disabled:</b> The <i>Load Demand Scheme</i> is disabled.</p>
Starting Options	<p>Determines how the load demand scheme operates upon start-up.</p> <p><b>Continuous Running, Load all Initially:</b> Upon activation of the load demand scheme, all sets in the system start up and parallel onto the generator bus. As load demands, sets go off load / on load. The set continues to run regardless of load levels until requested to stop.</p> <p><b>Continuous Running, Load as Required:</b> Upon activation of the load demand scheme, only one set starts initially. Other sets in the system are only started according to demand. As load demands, sets become off load / on load. The set continues to run regardless of load levels until requested to stop.</p> <p><b>Start all sets initially:</b> Upon activation of the load demand scheme, all sets in the system start up and parallel onto the generator bus. As load demands sets start / stop. This option is particularly recommended in Multiset Mains standby applications where the load is likely to be greater than the capacity of a single set.</p> <p><b>Start sets as load requires:</b> Upon activation of the load demand scheme, only one set will start initially. Other sets in the system are only started according to demand. This option is recommended for mutual standby systems where the load is likely to be less than the capacity of a single set.</p>

Parameter descriptions are continued overleaf...

Parameter	Description
Load/Start Next Set on Warning	<p><b>▲ NOTE: Enabling <i>Start Next Set on Warning</i> results with the <i>All Warnings are Latched</i> option being forced on.</b></p> <p>Whenever a warning occurs, a start/load command is issued over the MSC link to start the next highest priority set. The set with the warning stops once the next highest priority set has joined the bus</p>
Allow Set to Start with Warning	<p><input type="checkbox"/> = If the MSC calls to start another set, generators which display a warning status alarm remain at rest, only generators with no warning alarm are started according to their priority number.</p> <p><input checked="" type="checkbox"/> = Allows a stationary generator with a warning alarm to start if requested.</p>
Balance Engine Hours	<p>Used in a Multiset system so that the engine's priority changes according to the amount of usage of the set.</p> <p>For instance, in a two set system.</p> <p>Set 1 has logged 100 running hours Set 2 has logged 20 running hours Balance engine hours are configured to 75 hours.</p> <p>As Set 2 has logged 80 hours less than Set 1. As this is greater than the configured 75 hours, Set 2 is the highest priority set.</p> <p>If all sets are within the configured Balance Engine Hours value, then the set Priority Number (See SCADA   Maintenance page) is followed.</p>
Load Demand Delay	<p>After closing into parallel, the generator is kept running for the period of the <i>Load Demand Delay</i> time before joining the <i>Load Demand Scheme</i>.</p>
Calling For Less Sets	<p>The kW load level at which the module decides that generator is disconnected from the generator bus. The generator does not disconnect from the bus when its percentage of kW is below the <i>Calling For Less Sets</i> value. Instead, the generator disconnects from the bus when it ensures that the remaining generators' kW percentage is at the <i>Calling For Less Sets</i> value when it disconnects. This prevents the system from reaching a point where the load is such that the generator starts and stops repeatedly.</p> <p>Once the load is below this level, the lowest priority generator in the sequence (determined using the <i>Genset Priority</i>) begins its <i>Return Delay</i> timer. Once this has expired, the generator ramps off and stops.</p> <p>If the load level rises above this set point during the <i>Return Delay</i> timer, the timer is cancelled and the generator continues to supply power to the load. This caters for short term reductions in kW load demand.</p>

Parameter descriptions are continued overleaf...

Editing the Configuration

Parameter	Description
Calling For More Sets	<p>The kW load level at which the module calls for additional generators to join the generator bus.</p> <p>Once the load is above this level, the highest priority generator that is not running in the sequence (determined using the <i>Genset Priority</i>) begins its <i>Start Delay</i> timer. Once this has expired, the generator joins the bus and ramps up.</p> <p>If the load level reduces below this set point during the <i>Start Delay</i> timer, the timer is cancelled and the generator enters its stops cycle. This caters for short term kW load demand.</p> <p>If the set fails to become available, it communicates this using the MSC Link which signals the next generator in the sequence to take its place.</p>
Minimum Sets to Run	<p>The minimum number of generators that have to remain on the bus regardless of the bus load level and the <i>Calling For Less Sets</i> value. The MSC system selects the highest priority number Gensets to remain on the bus.</p>

**Insufficient Capacity**

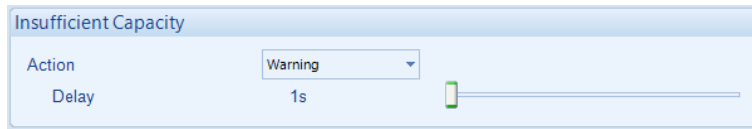

Parameter	Description
Action	<p>Activates when the governor output percentage reaches the maximum value for the configured <i>Delay</i> time. This indicates that the generator is not able to produce the kW requested due to having incorrect settings for SW1 and SW2 or a fault with the engine. The alarm action list is as follows, see section entitled <i>Alarm Types</i> for more information:</p> <p><b>Electrical Trip</b></p> <p><b>Indication</b></p> <p><b>None</b></p> <p><b>Shutdown</b></p> <p><b>Warning</b></p>

### 2.7.9.4.1 CREATING / EDITING THE DROOP CURVE

While the *DSE Configuration Suite* holds most commonly used droop curves, occasionally it is required that the module's droop function be configured for a specification application not listed by the *DSE Configuration Suite*. To aid this process, a droop curve editor is provided.

The droop curve that is to be used or edited.

Click to edit the droop curve or create a curve if a curve is not selected.

Click and drag the points on the graphs to change the settings

Double click the left mouse button to add a point or right click on a point to remove it.

Use the mouse to select the graph point, then enter the value in the box or click up/down to change the value

Click *Interpolate* then select two points as prompted to draw a straight line between

Click to change the range of the X and Y Axes of the graph and the level of open circuit

Click **SAVE AS**, a prompt to name the curve...

Click **OK** to accept the changes or **CANCEL** to ignore and lose the changes.

Click **OK** to save the curve.

**Any saved curves become selectable in the *Input Type* selection list.**

**Hint:** Deleting, renaming or editing custom sensor curves that have been added is performed in the main menu, select *Tools | Curve Manager*.

## 2.7.9.5 AVR

### Loss of Excitation

The screenshot shows the 'Loss Of Excitation' configuration window. It includes the following settings:

- Arming:** Active from Mains Parallel (dropdown)
- Pre-Alarm:**  (checkbox)
- Trip:** 25.0 % (slider)
- Return:** 20.0 % (slider)
- Alarm:**  (checkbox)
- Action:** Shutdown (dropdown)
- Trip:** 35.0 % (slider)
- Delay:** 1s (slider)

Parameter	Description
Arming	<p><b>NOTE:</b> For details of these, see the section entitled <i>Alarm Arming</i> elsewhere in this document.</p> <p>Select when the <i>Loss Of Excitation</i> alarm becomes active:  <b>Active from Mains Parallel</b>  <b>Always</b></p>
Loss Of Excitation Pre-Alarm IEEE 37.2 – 32 Directional Power Relay	<p><input type="checkbox"/> = <i>Loss of Excitation</i> does NOT give a pre-alarm warning  <input checked="" type="checkbox"/> = The <i>Loss of Excitation Pre-Alarm</i> is active when the measured negative kvar exceeds the <i>Loss of Excitation Pre-Alarm Trip</i> setting. The <i>Loss of Excitation Pre-Alarm</i> is automatically reset when the measured negative kvar no longer exceeds the configured <i>Loss of Excitation Pre-Alarm Return</i> level. The <i>Loss Of Excitation Trip</i> level is adjusted to suit user requirements.</p>
Loss Of Excitation Alarm IEEE 37.2 – 32 Directional Power Relay	<p><input type="checkbox"/> = Loss of excitation does NOT give a Shutdown alarm  <input checked="" type="checkbox"/> = The <i>Loss of Excitation Alarm</i> is active when the measured negative kvar exceeds the <i>Loss of Excitation Alarm</i> setting for the configured <i>Delay</i>. The <i>Loss Of Excitation Trip</i> level and action is adjusted to suit user requirements.</p>
Action	<p><b>NOTE:</b> For details of these, see the section entitled <i>Alarm Types</i> elsewhere in this document.</p> <p>Select the type of alarm required from the list:  <b>Electrical Trip</b>  <b>Shutdown</b></p>

**AVR Trim Alarm**

Parameter	Description
AVR Trim Alarm	<p>Activates when the AVR output percentage reaches the maximum value for the configured <i>Delay</i> time. This indicates that the generator is not able to produce the kvar requested due to having incorrect settings for SW1 and SW2, or a fault with the alternator. The alarm action list is as follows, see section entitled <i>Alarm Types</i> for more information:</p> <p><b><i>Electrical Trip</i></b>  <b><i>Indication</i></b>  <b><i>None</i></b>  <b><i>Shutdown</i></b>  <b><i>Warning</i></b></p>

### 2.7.9.6 POWER CONTROL

**NOTE:** The *Power Control* modes and *Voltage and Reactive Power Control* modes are to be used in conjunction with the following documents:  
- COMMISSION REGULATION (EU) 2016/631 of 14 April 2016 establishing a network code on requirements for grid connection of generators  
- P1547 - IEEE Draft Standard for Interconnection and Interoperability of Distributed Energy Resources with Associated Electric Power Systems Interfaces

**NOTE:** The *Simulation Injection Testing* tool of the DSE Configuration Suite PC Software allows testing the generator's frequency response and check its performance for the *Power Control* curves. For details on how to test the *Simulation Injection* on the DSE module refer to DSE Publication: 056-123 Simulation Injection Testing document.

**NOTE:** The *Power Control* parameters only have effect when a digital input is configured for *Mains Parallel Mode* instructing the module to operate in fixed export mode with the utility supply. For more information on this application, refer to DSE Publication: 056-054 DSE8x10 in Fixed Export (*Base Load*) which is found on our website: [www.deepseaelectronics.com](http://www.deepseaelectronics.com)

**NOTE:** Activation of the different *Power Control* modes is done through digital inputs, PLC functions, Front Panel Editor or Modbus; with digital inputs having higher priority over PLC functions, and PLC functions have higher priority over Front Panel Editor and Modbus commands.

**NOTE:** Simultaneously activating different *Power Control* modes, results in the lowest number taking priority.

#### Contact Power Mode (Default)

Constant Power Mode (Default)  
*No additional settings are required*

This is the default mode of exporting power to the Mains (utility); where the DSE load share controller holds the amount of power produced at a constant level. The amount of power produced by the generator is irrespective of the load level or any other parameter.

The amount of power produced is defined as Maximum kW Level and is set in *SCADA | Generator | Load Levels* section, through the Front Panel Running Editor, in PLC Functions, or via Modbus messages.

**Frequency-Power Mode**

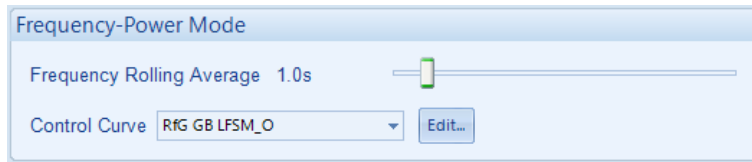

In this mode of exporting power to the Mains (utility); the DSE load share controller varies the amount of power produced with regards to the Control Curve depending on the measured frequency. This mode allows the generator to support the Mains (utility) frequency stability by monitoring the frequency and changing the amount of power produced.

Parameter	Description
Frequency Rolling Average	The measured frequency is averaged over the period of the <i>Frequency Rolling Average</i> . The average frequency is used in the <i>Control Curve</i> to determine the required level of power production.
Control Curve	<p>The <i>Control Curve</i> determines, based on the average frequency, the amount of power the generator produces. This amount of power is a percentage of the <i>kW Maximum Load Level</i> set within the SCADA section.</p> <p>Select the <i>Control Curve</i> from a pre-defined list or create a user-defined curve</p> <p><b>RfG GB LFSM_O</b>: Requirements for Generators Network Code in Great Britain, Limited Frequency Sensitive Mode Over frequency</p> <p><b>RfG GB LFSM_U</b>: Requirements for Generators Network Code in Great Britain, Limited Frequency Sensitive Mode Under frequency</p> <p><b>RfG GB LFSM_U and LFSM_O</b>: Requirements for Generators Network Code in Great Britain, Limited Frequency Sensitive Mode Under frequency and Over frequency</p> <p><b>RfG GB FSM 5%</b>: Requirements for Generators Network Code in Great Britain, Frequency Sensitive Mode at 5%</p> <p><b>P1547 60Hz 50%</b>: Requirements for Generators in United States, Frequency Sensitive Mode at 50%</p> <p><b>P1547 60Hz 75%</b>: Requirements for Generators in United States, Frequency Sensitive Mode at 75%</p> <p><b>P1547 60Hz 90%</b>: Requirements for Generators in United States, Frequency Sensitive Mode at 90%</p>

**Voltage-Power Mode**

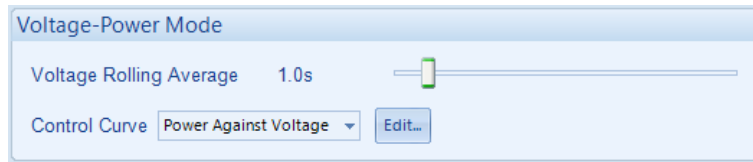

In this mode of exporting power to the Mains (utility); the DSE load share controller varies the amount of power produced with regards to the Control Curve depending on the measured voltage. This mode allows the generator to support the Mains (utility) voltage stability by monitoring the voltage and changing the amount of power produced.

Parameter	Description
Voltage Rolling Average	The measured voltage is averaged over the period of the <i>Voltage Rolling Average</i> . The average voltage is used in the <i>Control Curve</i> to determine the required level of power production.
Control Curve	The <i>Control Curve</i> determines, based on the average voltage, the amount of power the generator produces. This amount of power is a percentage of the <i>kW Maximum Load Level</i> .  Select the <i>Control Curve</i> from a pre-defined list or create a user-defined curve <b><i>Power Against Voltage</i></b>

**Power Ramp on Setpoint Change**

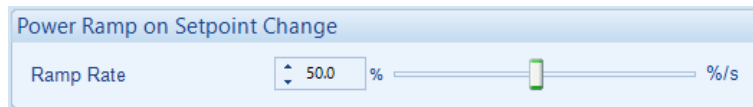

Parameter	Description
Ramp Rate	When changing between <i>Power Control</i> modes or changing the set point, the <i>Ramp Rate</i> defines how fast the output power changes in percentage points per second.

### 2.7.9.6.1 CREATING / EDITING THE POWER MODE CURVE

While the *DSE Configuration Suite* holds most commonly used droop curves, occasionally it is required that the module's droop function be configured for a specification application not listed by the *DSE Configuration Suite*. To aid this process, a droop curve editor is provided.

The droop curve that is to be used or edited.

Click to edit the droop curve or create a curve if a curve is not selected.

Click and drag the points on the graphs to change the settings

Use the mouse to select the graph point, then enter the value in the box or click up/down to change the value

Double click the left mouse button to add a point or right click on a point to remove it.

Click *Interpolate* then select two points as prompted to draw a straight line between

Click to change the range of the X and Y Axes of the graph and the level of open circuit

Click **SAVE AS**, a prompt to name the curve...

Click **OK** to accept the changes or **CANCEL** to ignore and lose the changes.

Click **OK** to save the curve.

**Any saved curves become selectable in the *Input Type* selection list.**

**Hint:** Deleting, renaming or editing custom sensor curves that have been added is performed in the main menu, select *Tools | Curve Manager*.

### 2.7.9.7 VOLTAGE AND REACTIVE POWER CONTROL

**NOTE:** The *Power Control* modes and *Voltage and Reactive Power Control* modes are to be used in conjunction with the following documents:  
 - COMMISSION REGULATION (EU) 2016/631 of 14 April 2016 establishing a network code on requirements for grid connection of generators  
 - P1547 - IEEE Draft Standard for Interconnection and Interoperability of Distributed Energy Resources with Associated Electric Power Systems Interfaces

**NOTE:** The *Simulation Injection Testing* tool of the DSE Configuration Suite PC Software allows testing the generator's voltage response and check its performance for the *Voltage & Reactive Power Control* curves. For details on how to test the *Simulation Injection* on the DSE module refer to DSE Publication: 056-123 Simulation Injection Testing document.

**NOTE:** The *Voltage and Reactive Power Control* parameters only have effect when a digital input is configured for *Mains Parallel Mode* instructing the module to operate in fixed export mode with the utility supply. For more information on this application, refer to DSE Publication: 056-054 DSE8x10 in Fixed Export (Base Load) which is found on our website: [www.deepseaelectronics.com](http://www.deepseaelectronics.com)

**NOTE:** Activation of the different *Voltage and Reactive Power Control* modes is done through digital inputs, PLC functions, Front Panel Editor or Modbus; with digital inputs having higher priority over PLC functions, and PLC functions have higher priority over Front Panel Editor and Modbus commands.

**NOTE:** Simultaneously activating different *Voltage and Reactive Power Control* modes, results in the lowest number taking priority.

#### Constant Power Factor Mode

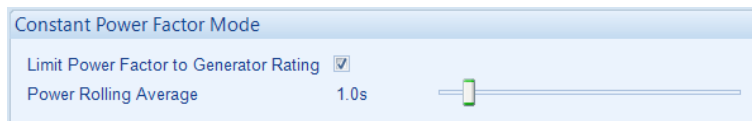

In this mode of exporting power to the Mains (utility); the DSE load share controller varies the amount of reactive power produced with regards to maintaining the required power factor. This mode allows the generator to maintain a constant export power factor if so required. The required power factor is set in *SCADA | Generator | Load Levels* section, through the Front Panel Running Editor, PLC Functions, or Modbus messages.

Parameter	Description
Limit Power Factor to Generator Rating	<input type="checkbox"/> = The generator produces power beyond it's specified power factor rating configured within the <i>Generator Rating</i> section. This may lead to the generator producing excessive positive or negative kvar. <input checked="" type="checkbox"/> = The generator produces power within its specified power factor rating configured within the <i>Generator Rating</i> section
Power Rolling Average	The exported power is averaged over the period of the <i>Power Rolling Average</i> . The average power is then used to determine the required reactive power production to achieve the set power factor.

**Voltage-Reactive Power Mode**

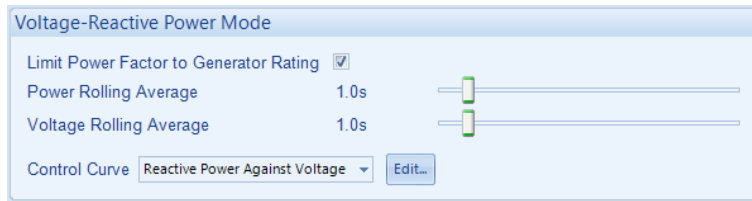

In this mode of exporting power to the Mains (utility); the DSE load share controller varies the amount of reactive power produced with regards to the Control Curve depending on the measured voltage. This mode allows the generator(s) to support the Mains (utility) voltage stability by monitoring the voltage and changing the amount of reactive power produced.

Parameter	Description
Limit Power Factor to Generator Rating	<input type="checkbox"/> = The generator produces power beyond it's specified power factor rating configured within the <i>Generator Rating</i> section. This may lead to the generator producing excessive positive or negative kvar. <input checked="" type="checkbox"/> = The generator produces power within its specified power factor rating configured within the <i>Generator Rating</i> section
Power Rolling Average	The exported power is averaged over the period of the <i>Power Rolling Average</i> . The average power is used to calculate the power factor if the option <i>Limit Power Factor To Generator Rating</i> is enabled.
Voltage Rolling Average	The measured voltage is averaged over the period of the <i>Voltage Rolling Average</i> . The average voltage is used in the <i>Control Curve</i> to determine the required level of reactive power production.
Control Curve	The <i>Control Curve</i> determines, based on the average voltage, the amount of reactive power the generator produces. This amount of power is a percentage of the <i>kvar Maximum Load Level</i> .  Select the <i>Control Curve</i> from a pre-defined list or create a user-defined curve <b><i>Reactive Power Against Voltage</i></b>

**Power-Power Factor Mode**

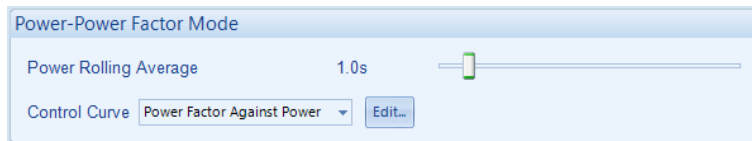

In this mode of exporting power to the Mains (utility); the DSE load share controller varies the amount of reactive power produced with regards to maintaining the required power factor. This power factor is derived from the averaged power using the *Control Curve*. This mode allows the generator to support the Mains (utility) stability by varying the power factor depending on the export power.

Parameter	Description
Power Rolling Average	The exported power is averaged over the period of the <i>Power Rolling Average</i> . The average is then used in the <i>Control Curve</i> to determine the required power factor.
Control Curve	The <i>Control Curve</i> determines, based on the average power, the power factor that is required.  Select the <i>Control Curve</i> from a pre-defined list or create a user-defined curve <b><i>Power Factor Against Power</i></b>

**Constant Reactive Power Mode (Default)**

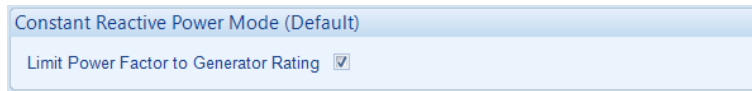

This is the default mode of exporting power to the Mains (utility); where the DSE load share controller holds the amount of reactive power produced at a constant level. The amount of reactive power produced by the generator is irrespective of the load level or any other parameter. The amount of reactive power produced is defined as *Maximum kvar Level* and is set in SCADA/Generator/Load Levels section, through the Front Panel Running Editor, in PLC Functions, or via Modbus messages.

Parameter	Description
Limit Power Factor to Generator Rating	<input type="checkbox"/> = The generator produces power beyond it's specified power factor rating configured within the <i>Generator Rating</i> section. This may lead to the generator producing excessive positive or negative kvar. <input checked="" type="checkbox"/> = The generator produces power within its specified power factor rating configured within the <i>Generator Rating</i> section

**Reactive Power Ramp on Setpoint Change**

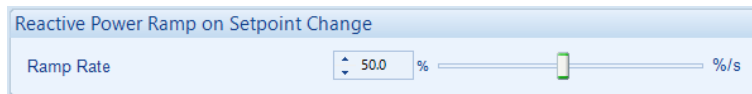

Parameter	Description
Ramp Rate	When changing between <i>Voltage and Reactive Power Control</i> modes or changing the set point, the <i>Ramp Rate</i> defines how fast the output reactive power changes in percentage points per second.

## 2.7.10 BUS

### Bus Settings

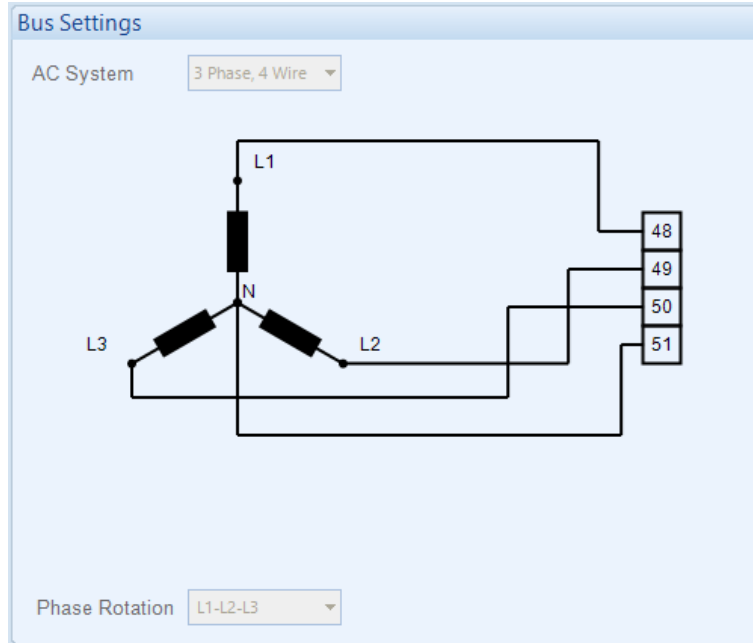

Parameter	Description
Bus Settings	All the <i>Bus Settings</i> are locked to the same configuration as the <i>Generator Settings</i> . This section is displayed for clarification purposes only.

### Bus Phase Rotation

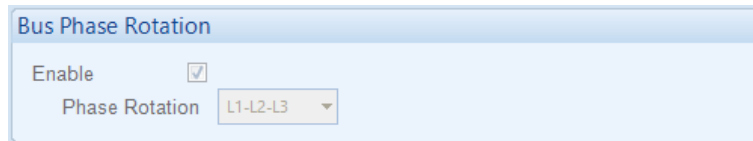

Parameter	Description
Bus Phase Rotation	All the <i>Bus Phase Rotation</i> settings are locked to the same configuration as the <i>Generator Phase Rotation</i> settings. This section is displayed for clarification purposes only.

## 2.7.11 FAULT RIDE THROUGH

 **NOTE:** To configure these settings refer to the appropriate grid standards for paralleling with the mains.

 **NOTE:** The *Fault Ride Through* feature is used to prevent the generator being disconnected from the Mains when in parallel during a momentary Mains Failure. Care **MUST** be taken when configuring the *Fault Ride Through* feature as a prolonged time in parallel with a failed mains might cause a damage to the generator.

 **NOTE:** For details on how the *Fault Ride Through* function operates refer to DSE Publication: 057-254 DSE8610 MKII Operator Manual which is found on our website: [www.deepseaelectronics.com](http://www.deepseaelectronics.com).

The *Fault Ride Through* feature is useful to prevent Electrical Trips on voltage dips caused by the grid when the generator is running in *Mains Parallel Mode*. This feature is also applicable on generators paralleling. The feature is to ignore the following *Electrical Trip* and *Shutdown* alarms:

- *Reverse Power*
- *Short Circuit*
- *Negative Phase Sequence*
- *Overcurrent*
- *Under Voltage*
- *Over Voltage*
- *Under Frequency*
- *Over Frequency*
- *Under Speed*
- *Over Speed*
- *Mains Decoupling Voltage & Frequency Stage Alarms*
- *Over Load*
- *Low Load*
- *Phase Rotation*
- *Earth Fault*

The *Fault Ride Through* curve must be configured which is formed of a sequence of *Connection Point Voltages* which increase after consecutive time intervals. The *Fault Ride Through* curve allows to ignore the undervoltage alarms as long as the voltage dips are above the configured voltage levels defined by setpoints out of one, for the given times in seconds.

The *Fault Ride Through* event activates when the voltage on one or more of the generator phases falls below the *Urec3* level; and it is cleared when the *Trec4* timer expires and the voltage rises above the *Urec3* level.

The *Connection Point Voltages* are configured in *PU (Per Unit)* which represent the percentages of the *Generator Nominal Voltage*; (i.e. 0.30PU = 30%).  
All the timers are configured in seconds.

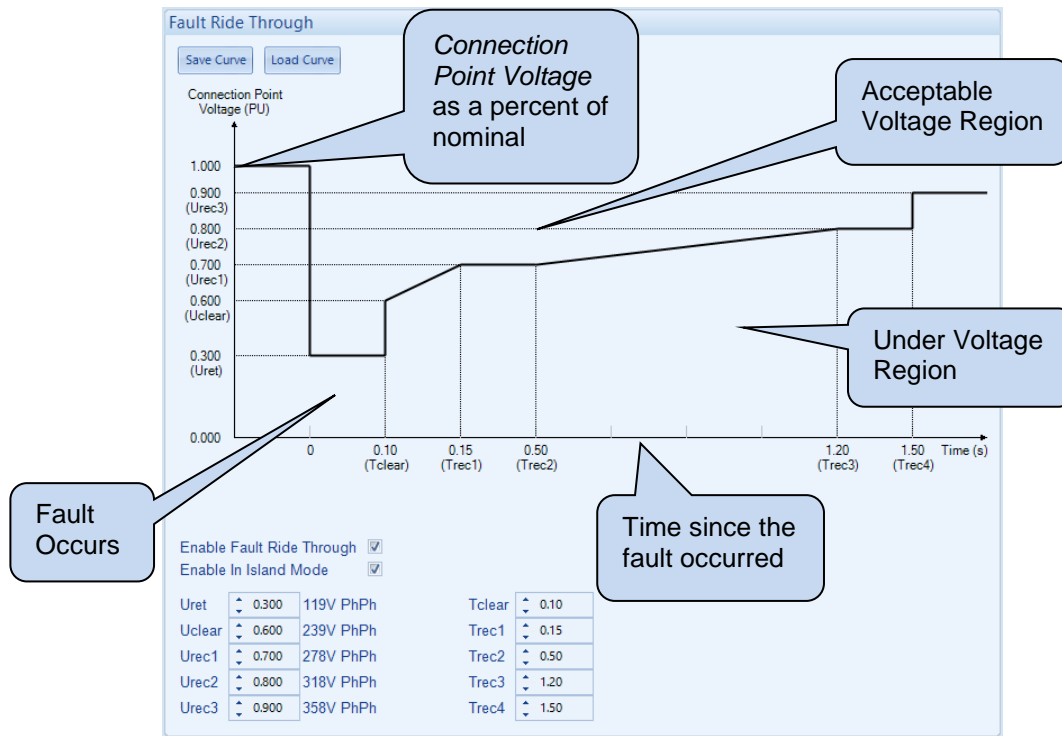

Parameter	Description
Enable Fault Ride Through	<input type="checkbox"/> = <i>Fault Ride Through</i> is disabled when in <i>Mains Parallel Mode</i> <input checked="" type="checkbox"/> = <i>Fault Ride Through</i> is enabled when in <i>Mains Parallel Mode</i>
Enable In Island Mode	<input type="checkbox"/> = <i>Fault Ride Through</i> is disabled when load sharing with generators only. <input checked="" type="checkbox"/> = <i>Fault Ride Through</i> is enabled when load sharing with generators only.
Uret	When the <i>Fault Ride Through</i> event starts, the voltage must remain above this level to ignore the <i>Gen Low Voltage Electrical Trip</i> or <i>Shutdown</i> alarm.
Tclear	During the normal operation when the voltage drops below the Urec3 level this timer is started and the <i>Fault Ride Through</i> event is activated. After this time, the DSE module monitors the voltage to ensure it remains above the FRT curve to ignore the alarms. This timer ends at the next <i>Connection Point Voltage</i> (Uclear) of the curve.
Uclear	The next <i>Connection Point Voltage</i> level at the Tclear time, above which the voltage must be to ignore the <i>Gen Low Voltage Alarm</i> .
Trec1	The time in seconds that the <i>FRT event</i> is active for. The voltage must be raised above the Urec1 level at this time.
Urec1	The next <i>Connection Point Voltage</i> level after the Trec1 time, above which the dipped voltage must be to ignore the <i>Gen Low Voltage Alarm</i> .
Trec2	The time in seconds that the <i>FRT event</i> is active for. After this time, the voltage must be raised above the Urec1 level to ignore the <i>Gen Low Voltage Alarm</i> .
Urec2	The next <i>Connection Point Voltage</i> level after the Trec3 time, above which the voltage must be to ignore the <i>Gen Low Voltage Alarm</i> .
Trec3	The time in seconds that the <i>FRT event</i> is active for. At this time, the voltage must be raised above the Urec2 level, but if the voltage is still below the Urec2, then the <i>Fault Ride Through</i> event terminates and the alarms are no longer ignored.

Parameters detailed overleaf...

Parameter	Description
Urec3	The next <i>Connection Point Voltage</i> level after the <i>Trec4</i> time, above which the voltage must be to terminate the <i>Fault Ride Through</i> event and activate the alarms.
Trec4	The time in seconds after which the DSE module monitors the voltage level to be raised above the <i>Urec3</i> to clear the <i>Fault Ride Through</i> event. After this time, all the alarms are active until another Fault Ride Through event occurs. At this point, if the voltage is still below the <i>Urec3</i> level, then the <i>Fault Ride Through</i> event remains active and the DSE module waits until the voltage is raised above the <i>Urec3</i> to clear the <i>Fault Ride Through</i> event.

### Save / Load Curve

This feature is used to import the *Fault Ride Through* settings into another DSE module.

Parameter	Description
Save Curve	This allows saving the current configured settings of the <i>Fault Ride Through</i> into an FRT file.
Load Curve	This allows loading of previously configured settings of the <i>Fault Ride Through</i> saved in FRT format.

## 2.8 ENGINE

The *Engine* section is subdivided into smaller sections. Select the required section with the mouse.

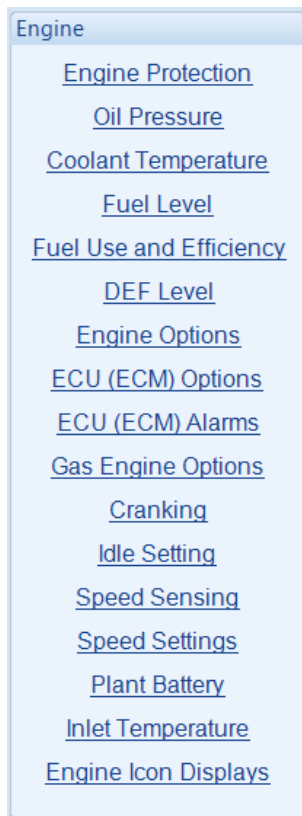

## 2.8.1 ENGINE PROTECTION

### Water in Fuel

**Water In Fuel**

Action Warning ▾

Arming Always ▾

Activation Delay 0s

Parameter	Description
Action	<p>The alarm activates when a <i>Water in Fuel</i> alarm is received from the engine ECU, or if a digital input configured for <i>Water in Fuel</i> activates for longer than the configured <i>Activation Delay</i> timer.</p> <p>The alarm action list is as follows, see section entitled <i>Alarm Types</i> for more information:</p> <p><b>None</b>  <b>Electrical Trip</b>  <b>Shutdown</b>  <b>Warning</b></p>
Arming	<p>Select when the alarm is active, see section entitled <i>Alarm Arming</i> for more information:</p> <p><b>Active from Breaker Closed</b>  <b>Active from Parallel</b>  <b>Always</b>  <b>From Safety On</b>  <b>From Starting</b>  <b>Never</b>  <b>When Stationary</b></p>

### Fuel Tank Bund

**Fuel Tank Bund**

Action Warning ▾

Parameter	Description
Action	<p>The alarm goes active when a digital input configured for <i>Fuel Tank Bund Level High</i> activates</p> <p>The input is designed to connect to a level switch within the tank bund (sometimes known as the Fuel Retention Tank). This is used to detect fuel leaks and/or overflows.</p> <p>The alarm action list is as follows, see section entitled <i>Alarm Types</i> for more information:</p> <p><b>Electrical Trip</b>  <b>Shutdown</b>  <b>Warning</b></p>

## 2.8.2 OIL PRESSURE

**NOTE:** The DSE module reads oil pressure from the ECU (ECM) if the selected Engine Application supports it. In these cases, Analogue Input A is configured as Flexible Analogue or Digital Input. Configuration of Flexible Analogue Inputs and Digital Inputs is detailed elsewhere in this document.

### Input Type

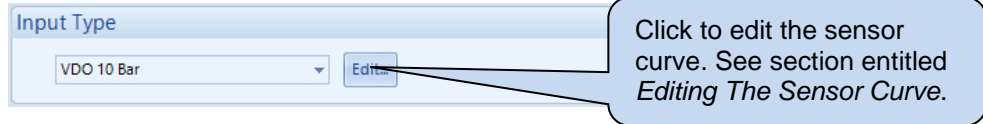

Parameter	Description
Input Type	Select the sensor type and curve from a pre-defined list or create a user-defined curve <b>Resistive:</b> for sensors with maximum range of 0 $\Omega$ to 480 $\Omega$ <b>Current:</b> for sensors with maximum range of 0 mA to 20 mA <b>Voltage:</b> for sensors with maximum range of 0 V to 10 V

### Sensor Open Circuit Alarm

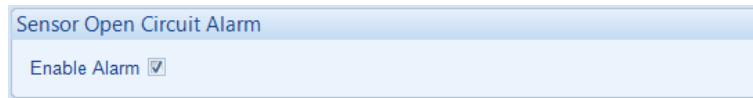

Parameter	Description
Enable Alarm	<input type="checkbox"/> = Alarm is disabled. <input checked="" type="checkbox"/> = The <i>Low Oil Pressure Open Circuit Alarm</i> is active when the module detects an open circuit when the sensor is disconnected

### Low Oil Pressure Alarms



Parameter	Description
Low Oil Pressure Shutdown	<input type="checkbox"/> = Alarm is disabled. <input checked="" type="checkbox"/> = The <i>Low Oil Pressure Shutdown Alarm</i> is active when the measured oil pressure drops below the configured <i>Trip</i> level.
Low Oil Pressure Pre-Alarm	<input type="checkbox"/> = Alarm is disabled. <input checked="" type="checkbox"/> = The <i>Low Oil Pressure Warning Alarm</i> is active when the measured oil pressure drops below the configured <i>Trip</i> level. The warning is automatically reset when the oil pressure increases above the configured <i>Return</i> level.

### 2.8.3 COOLANT TEMPERATURE

The *Coolant Temperature* page is subdivided into smaller sections. Select the required section with the mouse.

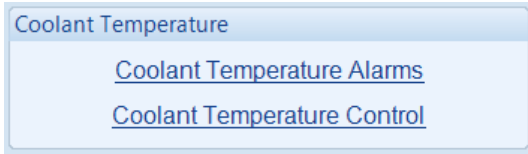

#### 2.8.3.1 COOLANT TEMPERATURE ALARM

**NOTE:** The DSE module reads oil pressure from the ECU (ECM) if the selected Engine Application supports it. In these cases, Analogue Input B is configured as Flexible Analogue or Digital Input. Configuration of Flexible Analogue Inputs and Digital Inputs is detailed elsewhere in this document.

#### Input Type

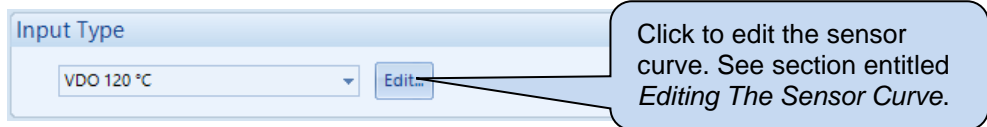

Parameter	Description
Input Type	Select the sensor type and curve from a pre-defined list or create a user-defined curve <b>Resistive:</b> for sensors with maximum range of 0 $\Omega$ to 480 $\Omega$ <b>Current:</b> for sensors with maximum range of 0 mA to 20 mA <b>Voltage:</b> for sensors with maximum range of 0 V to 10 V

#### Sensor Open Circuit Alarm

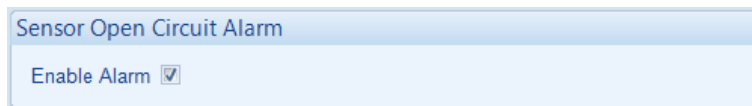

Parameter	Description
Enable Alarm	<input type="checkbox"/> = Alarm is disabled. <input checked="" type="checkbox"/> = The <i>Coolant Temperature Open Circuit Alarm</i> is active when the module detects an open circuit when the sensor is disconnected

### Low Coolant Temperature Alarms

Parameter	Description
Low Coolant Temperature Pre-Alarm	<input type="checkbox"/> = Alarm is disabled. <input checked="" type="checkbox"/> = The <i>Low Coolant Temperature Warning Alarm</i> is active when the measured coolant temperature falls below the configured <i>Trip</i> level. The <i>Warning</i> is automatically reset when the coolant temperature rises above the configured <i>Return</i> level.

### High Coolant Temperature Alarms

Parameter	Description
High Coolant Temperature Pre-Alarm	<input type="checkbox"/> = Alarm is disabled. <input checked="" type="checkbox"/> = The <i>High Coolant Temperature Warning Alarm</i> is active when the measured coolant temperature rises above the configured <i>Trip</i> level. The <i>Warning</i> is automatically reset when the coolant temperature falls below the configured <i>Return</i> level.
High Coolant Temperature Electrical Trip	<input type="checkbox"/> = Alarm is disabled. <input checked="" type="checkbox"/> = The <i>High Coolant Temperature Controlled Shutdown Alarm</i> is active when the measured coolant temperature rises above the configured <i>Trip</i> level.
High Coolant Temperature Shutdown	The <i>High Coolant Temperature Shutdown Alarm</i> is active when the measured coolant temperature rises above the configured <i>Trip</i> level.

### 2.8.3.2 COOLANT TEMPERATURE CONTROL

#### Coolant Heater Control

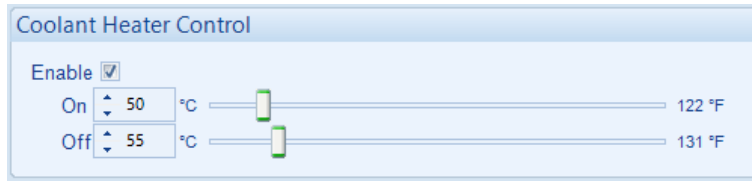

Parameter	Description
Coolant Heater Control	<input type="checkbox"/> = Coolant Heater Control function is disabled <input checked="" type="checkbox"/> = The digital output configured to <i>Coolant Heater Control</i> is energised when the engine coolant temperature falls below the configured <i>On</i> level. This is designed to control an external engine heater. When the coolant temperature rises above the configured <i>Off</i> level, the digital output is de-energised.

#### Coolant Cooler Control

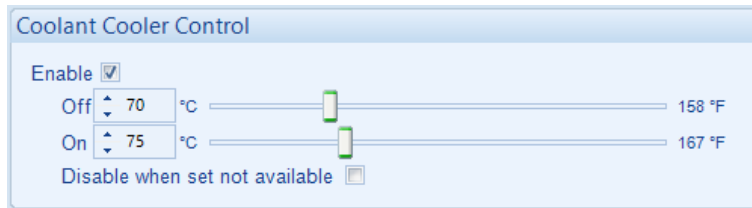

Parameter	Description
Coolant Cooler Control Enable	<input type="checkbox"/> = Coolant Cooler Control function is disabled <input checked="" type="checkbox"/> = The digital output configured to <i>Coolant Cooler Control</i> is energised when the engine coolant temperature exceeds the configured <i>On</i> level. This is designed to control an external engine cooling system, for instance an additional cooling fan. When the coolant temperature falls below the configured <i>Off</i> level, the digital output is then de-energised.

#### Fan Control

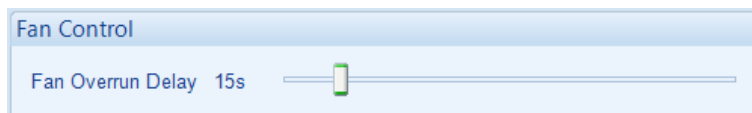

Parameter	Description
Fan Control	An output configured to <i>Fan Control</i> energises when the engine becomes available (up to speed). This output is designed to control an external cooling fan. When the engine stops, the cooling fan remains running for the duration of the <i>Fan Overrun Delay</i> .

## 2.8.4 FUEL LEVEL

The *Fuel Level* page is subdivided into smaller sections. Select the required section with the mouse.

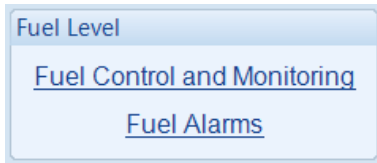

### 2.8.4.1 FUEL CONTROL AND MONITORING

#### Input Type

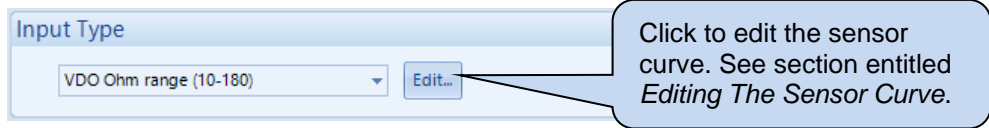

Parameter	Description
Input Type	Select the sensor type and curve from a pre-defined list or create a user-defined curve <b>Resistive:</b> for sensors with maximum range of 0 $\Omega$ to 480 $\Omega$ <b>Current:</b> for sensors with maximum range of 0 mA to 20 mA <b>Voltage:</b> for sensors with maximum range of 0 V to 10 V

In the case of a parallel sided fuel tank, an accurate measure of the fuel level is easily made, however this is not the case with non-parallel sided fuel tanks. Alteration to the fuel level sensor curve is required for non-parallel sided to attain more accurate level indication. This is because a fuel level sensor measures the distance between the top of the tank and the fuel level.

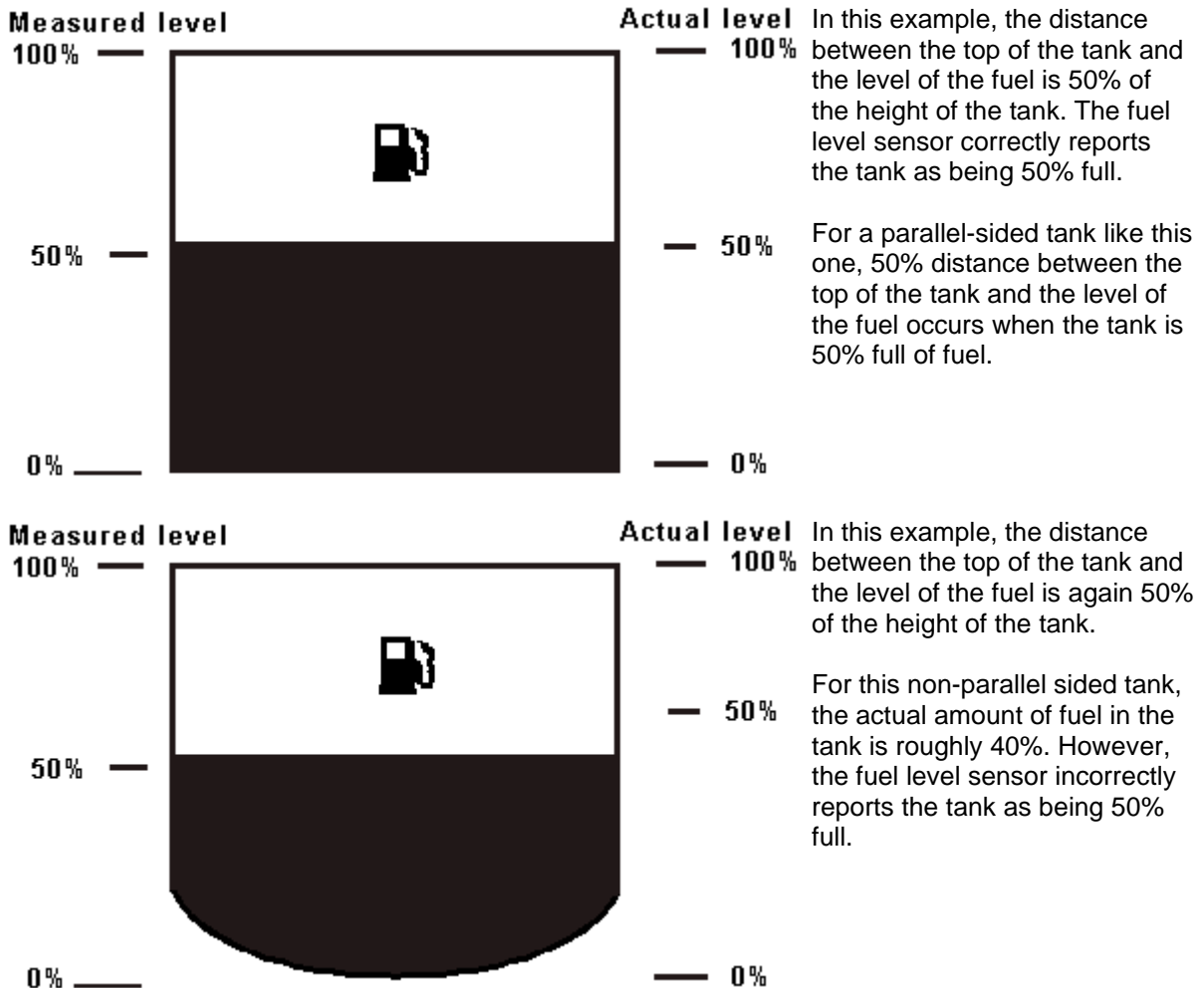

**Fuel Pump Control**

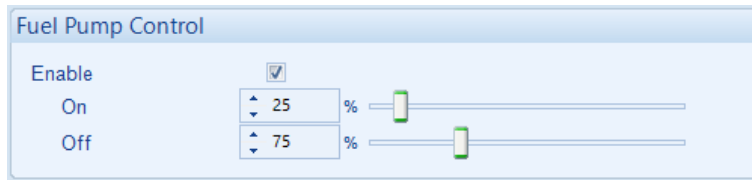

Parameter	Description
Fuel Pump Control Enable	<p><input type="checkbox"/> = Fuel Pump Control is disabled.</p> <p><input checked="" type="checkbox"/> = Allows the module to control an external fuel pump to transfer fuel from a bulk tank to the day tank.</p> <p>A digital output configured for <i>Fuel Pump Control</i> energises when the fuel level falls below the configured <i>On</i> setting and de-energises when the fuel level exceeds the configured <i>Off</i> setting.</p>

**Fuel Monitoring**

**NOTE:** Sending events by SMS is only available when the module is configured to communicate to a supported modem by RS232. Refer to section entitled *RS232 Port* elsewhere in this document for further details.

Parameter	Description
Fuel Tank Size	Select the tank size and the units for the module's display: <i>Imperial Gallons</i> <i>Litres</i> <i>US Gallons</i>
Logging Interval	The interval at which the fuel level is stored in the event log.
Dial Out on Logging	<input type="checkbox"/> = Dial Out on Logging is disabled. <input checked="" type="checkbox"/> = Dial Out on Logging is enabled. When the <i>Fuel Level</i> is recorded in the module's event log, the module dials the pre-configured number of a PC.
SMS Enabled	<input type="checkbox"/> = <i>Fuel Level Values</i> are not sent by SMS message. <input checked="" type="checkbox"/> = The value of the <i>Fuel Level</i> is sent by SMS message at the configured <i>SMS Interval</i> based on the <i>Logging Interval</i> .
Stable Timer	The controller maintains a rolling record of the fuel level percentage for the duration of the <i>Stable Timer</i> .  When the rolling record of the fuel level percentage indicates that the fuel level has increased more than the <i>Change Indicating Filling</i> during the <i>Stable Timer</i> , the controller records a <i>Fuel Filling Start</i> event in its event log.  When the rolling record of the fuel level indicates that the fuel level has not changed more than the <i>Change Indicating Stable</i> during the <i>Stable Timer</i> , the controller records a <i>Fuel Filling Stop</i> event in its event log.

Parameter descriptions are continued overleaf...

Parameter	Description
Change Indicating Filling	<p>When the fuel level increases at a rate higher than</p> <p><b><u>Change Indicating Filling</u></b> <i>Stable Timer</i></p> <p>Then a fuel fill start event is recorded into the event log. Depending on configuration this generates a dial out or SMS message.</p> <p><b>Example</b> <i>Stable Timer</i> = 1 minute <i>Change Indicating Filling</i> = 3 %</p> <p>When the fuel level increases by more than 3% in 1 minute, a fuel fill event is recorded.</p>
Change Indicating Stable	<p>During filling, if the fuel level increases at a rate less than</p> <p><b><u>Change Indicating Stable</u></b> <i>Stable Timer</i></p> <p>then a fuel fill end event is recorded into the event log. Depending on configuration this generates a dial out or SMS message.</p> <p><b>Example:</b> <i>Stable Timer</i> = 1 minute <i>Change Indicating Stable</i> = 2 %</p> <p>When the fuel level increases by less than 2% in 1 minute, a fuel fill end event is recorded.</p>

### 2.8.4.2 FUEL ALARMS

#### Low Fuel Level Alarms

Parameter	Description
Low Fuel Level Alarm	<input type="checkbox"/> = Alarm is disabled. <input checked="" type="checkbox"/> = The <i>Low Fuel Level Alarm</i> activates with the configured <i>Action</i> when the measured fuel level drops below the <i>Trip</i> setting for the configured <i>Delay</i> time.
Action	<div style="border: 1px solid black; padding: 5px;"> <p><b>NOTE:</b> For details of these, see the section entitled <i>Alarm Types</i> elsewhere in this document.</p> </div> <p>Select the type of alarm required from the list:</p> <p><b><i>Electrical Trip</i></b></p> <p><b><i>Shutdown</i></b></p>
Low Fuel Level Pre-Alarm	<input type="checkbox"/> = Alarm is disabled. <input checked="" type="checkbox"/> = The <i>Low Fuel Level Pre-Alarm</i> activates with the configured <i>Action</i> when the measured fuel level drops below the <i>Low Pre-Alarm Trip</i> setting for the configured <i>Delay</i> time. The pre-alarm is automatically reset when the fuel level exceeds the configured <i>Low Pre-Alarm Return</i> setting.

**High Fuel Level Alarms**

Parameter	Description
High Fuel Level Pre-Alarm	<input type="checkbox"/> = Alarm is disabled. <input checked="" type="checkbox"/> = The <i>High Fuel Level Pre-Alarm</i> activates with the configured <i>Action</i> when the measured fuel level rises above the <i>High Pre-Alarm Trip</i> setting for the configured <i>Delay</i> time. The pre-alarm is automatically reset when the fuel level drops below the configured <i>High Pre-Alarm Return</i> setting.
High Fuel Level Alarm	<input type="checkbox"/> = Alarm is disabled. <input checked="" type="checkbox"/> = The <i>High Fuel Level Alarm</i> activates with the configured <i>Action</i> when the measured fuel level raises above the <i>Trip</i> setting for the configured <i>Delay</i> time.
Action	<div style="border: 1px solid black; padding: 5px;"> <p><b>NOTE:</b> For details of these, see the section entitled <i>Alarm Types</i> elsewhere in this document.</p> </div> <p>Select the type of alarm required from the list:  <b>Electrical Trip</b>  <b>Shutdown</b></p>

**Fuel Usage Alarm**

Parameter	Description
Fuel Usage Alarm Enable	<p><input type="checkbox"/> = Alarm is disabled.</p> <p><input checked="" type="checkbox"/> = Provides an alarm to monitor the usage of the fuel. The alarm activates when the fuel level drops at a higher rate than the configured <i>Running Rate</i> while the engine is running. Or if the fuel level drops at a higher rate than the configured <i>Stopped Rate</i> while the engine is stopped. This alarm is provided to check for fuel leakage problems or potential fuel theft.</p>
Mode	<p><b>Sampling Window:</b> The fuel usage alarm activates when the fuel level decreases at a higher rate per <i>Sampling Window</i> than the configured <i>Running Rate</i> while the engine is running, or <i>Stopped Rate</i> while the engine is stopped.</p> <p><b>Standard Mode:</b> The fuel usage alarm activates when the fuel level decreases at a higher rate per hour than the configured <i>Running Rate</i> while the engine is running, or <i>Stopped Rate</i> while the engine is stopped.</p>
Action	<p>The alarm action list is as follows, see section entitled <i>Alarm Types</i> for more information:</p> <p><b>Electrical Trip</b>  <b>Latched Indication</b>  <b>Shutdown</b>  <b>Warning Always Latched</b></p>

## 2.8.5 FUEL USE AND EFFICIENCY

### Engine Efficiency Curve

Parameter	Description
Engine Type	Select the engine type from a pre-defined list or create a user-defined curve.
Specific Gravity	The relative fuel density of the fuel (usually given as kg/m <sup>3</sup> ) being consumed by the generator.

### Instrumentation Sources

Parameter	Description
Instantaneous Fuel Consumption	<b>Not Used:</b> <i>Instantaneous Fuel Consumption</i> is not displayed <b>Efficiency Curve:</b> The DSE module calculates the <i>Instantaneous Fuel Consumption</i> as Litre/hour from <i>Generator Total kW Percentage</i> using the <i>Efficiency Curve</i> and <i>Specific Gravity</i> . <b>Engine ECU:</b> The DSE module reads the <i>Instantaneous Fuel Consumption</i> as Litre/hour from the engine ECU.
Trip Average Fuel Consumption	<b>Not Used:</b> <i>Trip Average Fuel Consumption</i> is not displayed <b>Efficiency Curve:</b> The DSE module calculates the <i>Trip Average Fuel Consumption</i> as litre/hour over the current or last run from <i>Generator Total kW Percentage</i> using the <i>Efficiency Curve</i> and <i>Specific Gravity</i> . <b>Engine ECU:</b> The DSE module reads the <i>Trip Average Fuel Consumption</i> as litre/hour over the current or last run from the engine ECU. <b>Module Sensor:</b> The DSE module calculates the <i>Trip Average Fuel Consumption</i> as litre/hour over the current or last run from the change in fuel tank level using the <i>Fuel Tank Size</i> .
Trip Fuel Usage	<b>Not Used:</b> <i>Trip Fuel Usage</i> is not displayed <b>Efficiency Curve:</b> The DSE module calculates the <i>Trip Fuel Usage</i> as litres over the current or last run from <i>Generator Total kW Percentage</i> using the <i>Efficiency Curve</i> and <i>Specific Gravity</i> . <b>Engine ECU:</b> The DSE module reads the <i>Trip Fuel Usage</i> as litres over the current or last run from the engine ECU. <b>Module Sensor:</b> The DSE module calculates the <i>Trip Fuel Usage</i> as litres over the current or last run from the change in fuel tank level using the <i>Fuel Tank Size</i> .

Parameter descriptions are continued overleaf...

Parameter	Description
Accumulated Fuel Usage	<p><b>Not Used:</b> <i>Accumulated Fuel Usage</i> is not displayed</p> <p><b>Efficiency Curve:</b> The DSE module calculates the <i>Accumulated Fuel Usage</i> as litres over the entire run time from <i>Generator Total kW Percentage</i> using the <i>Efficiency Curve</i> and <i>Specific Gravity</i>.</p> <p><b>Engine ECU:</b> The DSE module reads the <i>Accumulated Fuel Usage</i> as litres over the entire run time from the engine ECU.</p> <p><b>Module Sensor:</b> The DSE module calculates the <i>Accumulated Fuel Usage</i> as litres over the entire run time from the change in fuel tank level using the <i>Fuel Tank Size</i>.</p>
Instantaneous Efficiency	<p><b>Not Used:</b> <i>Instantaneous Efficiency</i> is not displayed</p> <p><b>Efficiency Curve:</b> The DSE module calculates the <i>Instantaneous Efficiency</i> as kWh/litre from <i>Generator Total kW Percentage</i> using the <i>Efficiency Curve</i> and <i>Specific Gravity</i>.</p> <p><b>Engine ECU:</b> The DSE module reads the <i>Instantaneous Fuel Consumption</i> as Litre/hour from the engine ECU and calculates the <i>Instantaneous Efficiency</i> as kWh/litre using the <i>Generator Total kW Percentage</i>.</p>
Trip Average Efficiency	<p><b>Not Used:</b> <i>Trip Average Efficiency</i> is not displayed</p> <p><b>Efficiency Curve:</b> The DSE module calculates the <i>Trip Average Efficiency</i> as kWh/litre over the current or last run from <i>Generator Total kW Percentage</i> using the <i>Efficiency Curve</i> and <i>Specific Gravity</i>.</p> <p><b>Engine ECU:</b> The DSE module reads the <i>Trip Average Fuel Consumption</i> as Litre/hour from the engine ECU over the current or last run and calculates the <i>Trip Average Efficiency</i> as kWh/litre using the <i>Generator Total kW Percentage</i>.</p> <p><b>Module Sensor:</b> The DSE module calculates the <i>Trip Average Efficiency</i> as kWh/litre over the current or last run from the change in fuel tank level using the <i>Fuel Tank Size</i> and <i>Generator Total kW Percentage</i>.</p>
Estimate Run Time to Empty	<p><b>Not Used:</b> <i>Estimate Run Time to Empty</i> is not displayed</p> <p><b>Engine ECU:</b> The DSE module reads the <i>Instantaneous Fuel Consumption</i> as Litre/hour from the engine ECU and <i>Estimates Run Time to Empty</i> using the <i>Fuel Tank Size</i>.</p> <p><b>Module Sensor:</b> The DSE module <i>Estimates Run Time to Empty</i> using the <i>Run Time Until Empty</i> parameters.</p>

### Run Time Until Empty

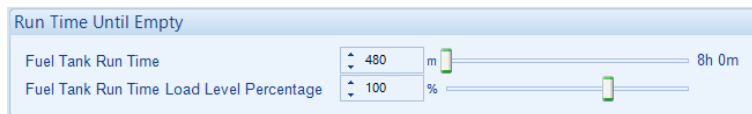

Parameter	Description
Fuel Tank Run Time	The time in minutes how long the generator's fuel tank last when running at the <i>Fuel Tank Run Time Load Level Percentage</i>
Fuel Tank Run Time Load Level Percentage	The percentage of full load kW the generator which is used to calculate how long the fuel in the tank lasts.

## 2.8.6 DEF LEVEL

**NOTE:** Configuration of alarms in this section only has effect when the ECU (ECM) supports DEF Level.

**NOTE:** Configuration of the *Alarm Action* in this section defines the DSE module response to the CANbus message; however, the ECU (ECM) still shuts down the engine depending on the alarm severity.

DEF Level is a CANbus message from the ECU (ECM). The following parameters allow configuration of how the DSE module responds to the DEF Level.

Parameter	Description
DEF Level Low Alarm Enable	<input type="checkbox"/> = Disable the alarm <input checked="" type="checkbox"/> = <i>DEF Low Alarm</i> will be activated when the <i>DEF Level</i> sent from the ECU is below the configured <i>Trip</i> level for longer than the configured <i>Delay</i> time.
Action	Select the type of alarm required from the list: <b>Electrical Trip</b> <b>Shutdown</b> For details of these, see the section entitled <i>Alarm Types</i> elsewhere in this document.
DEF Level Low Pre-Alarm	<input type="checkbox"/> = The Pre-alarm is disabled. <input checked="" type="checkbox"/> = <i>DEF Low Pre-Alarm</i> will be activated when the <i>DEF Level</i> sent from the ECU is below the configured <i>Trip</i> level for longer than the configured <i>Delay</i> time. The Pre-Alarm is deactivated when the <i>DEF Level</i> rises above the <i>Return</i> level.

## 2.8.7 ENGINE OPTIONS

### ECU (ECM) Options

**ECU (ECM) Options**

Engine Type Cummins CM2250

Enhanced J1939

Alternative Engine Speed

Modbus Engine Comms Port RS485 Port

Disable ECM Speed Control

These items are read only and not adjustable. To change these items, visit the *Module | Application* menu.

Parameter	Description
Disable ECM Speed Control	Disables speed control by the DSE module. Useful when an external device (i.e. remote speed potentiometer) is used to control engine speed.

### Miscellaneous Options

**NOTE:** For a full list of the J1939-75 alarms and instrumentation, refer to DSE Publication: *057-254 DSE8610 MKII Operator Manual* which is found on our website: [www.deepseaelectronics.com](http://www.deepseaelectronics.com)

**Miscellaneous Options**

J1939-75 Instrumentation Enable

J1939-75 Alarms Enable

CAN source address (instrumentation) 44

Parameter	Description
J1939-75 Instrumentation Enable	Allows the DSE module to be interrogated by another CAN device and transfer the generator set instrumentation over J1939 link.
J1939-75 Alarms Enable	Allows the DSE module to be interrogated by another CAN device and transfer the alarms over J1939 link.
CAN Source Address (Instrumentation)	Set the <i>CAN Source Address</i> for the DSE module over which other CANbus devices read the generator set instrumentation.

### Startup Options

**Startup Options**

Start Attempts 3

Parameter	Description
Start Attempts	<p>The number of starting attempts the module makes. If the module does not detect that the engine has fired before the end of the <i>Cranking Time</i>, then the current start attempt is cancelled and the <i>Crank Rest</i> time takes place before the next crank attempt begins. If, after all configured <i>start attempts</i>, the engine is not detected as running, the <i>Fail to Start</i> shutdown alarm is generated.</p> <p>The engine is detected as running by checking all methods of <i>Crank Disconnect</i>. For further details, see the section entitled <i>Crank Disconnect</i> elsewhere in this document.</p>

**Pre-heat**

**NOTE:** For this feature to have effect, configure a digital output for *Pre-Heat*.

**NOTE:** Depending on *Engine Type* configuration, this is controlled direct by the ECU (ECM).

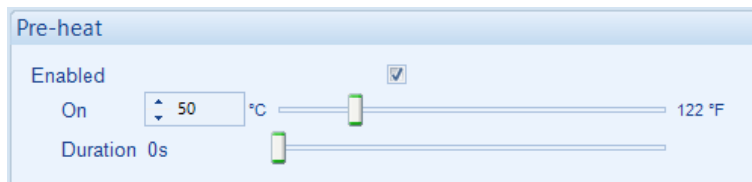

Parameter	Description
Enabled	<input type="checkbox"/> = Pre-heat is not temperature dependent. <input checked="" type="checkbox"/> = When the <i>Coolant Temperature</i> is below the configured <i>On</i> level, the <i>Pre-Heat</i> digital output is activated for the set <i>Duration</i> of time before cranking.
On	Set the coolant temperature below which the pre-heat is activated.
Duration	Set the time delay during which the <i>Pre-Heat</i> digital output remains active before cranking

**Post-heat**

**NOTE:** For this feature to have effect, configure a digital output for *Pre-Heat*.

**NOTE:** Depending on *Engine Type* configuration, this is controlled direct by the ECU (ECM).

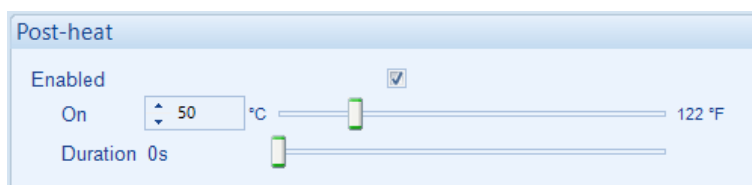

Parameter	Description
Enabled	<input type="checkbox"/> = Post-heat is not temperature dependent. <input checked="" type="checkbox"/> = When the <i>Coolant Temperature</i> is below the configured <i>On</i> level, the <i>Pre-Heat</i> digital output is activated for the set <i>Duration</i> of time after cranking and before the set is considered available.
On	Set the coolant temperature below which the pre-heat is activated.
Duration	Set the time delay during which the <i>Pre-Heat</i> digital output remains active after cranking and before the engine is considered available.

## 2.8.8 ECU (ECM) OPTIONS

### Engine Hours

Engine Hours

Module to Record Engine Hours

Parameter	Description
Module to Record Engine Hours	When enabled, DSE module counts Engine Run Hours. When disabled, Engine ECU (ECM) provides Run Hours.

### DPF Regeneration Control

DPF Regeneration Control

Allow Non-Mission Regeneration

Parameter	Description
DPF Regeneration Control	Available for ECUs (ECM) which require the engine speed to drop during a manual regeneration cycle. During this time, the generator is not available to supply power and the under speed and under frequency alarms are not active.

### Speed Switch

Speed Switch

Enable  Default Dataset ECU ▼

Parameter	Description
Speed Switch	Defines the method of speed control over CANbus when supported by the ECU (ECM). Selection needs to match the ECU (ECM) calibration for the speed control method. Available speed control methods to choose from: <b>0: CAN Open Increase Decrease</b> <b>1: ECU Increase Decrease Input</b> <b>2: CAN Open Increase Decrease</b> <b>3: ECU Analogue Absolute</b> <b>4: ECU Analogue Relative</b> <b>5: ECU Frequency Input</b> <b>6: ECU CANopen Analogue</b> <b>7: CANOpen Speed Demand</b>

Continued Overleaf...

**Example:**

For some Volvo *Engine Types*, the *Speed Switch* indicates specific options as shown below.

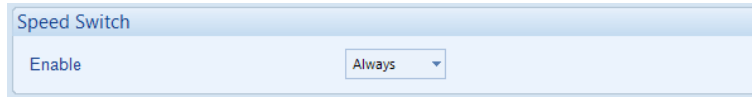

Parameter	Description
Speed Switch Enable	Defines the method of speed control over CANbus when supported by the Volvo ECU (ECM). Selection needs to match the ECU (ECM) calibration for the speed control method. Available speed control methods to choose from: <b>Always</b> <b>Never</b> <b>On Change</b>

**ECU Wakeup**

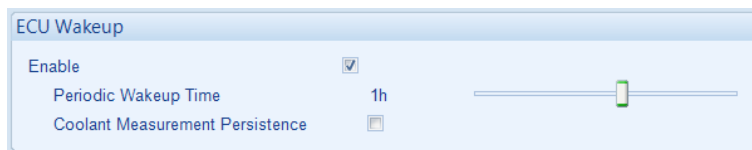

Parameter	Description
ECU Wakeup Enable	<input type="checkbox"/> = Option is disabled. <input checked="" type="checkbox"/> = When the engine is stopped, the DSE module sends a wakeup signal to the ECU (ECM) and keeps it powered up for the <i>ECU Override</i> time (configured in <i>Start Timers</i> ) to read the ECU (ECM) parameters. This is periodically repeated depending on the configured <i>Periodic Wakeup Time</i> .
Coolant Measurement Persistence	<b>NOTE: Available only when <i>ECU Wakeup</i> is enabled.</b> <input type="checkbox"/> = Option is disabled. <input checked="" type="checkbox"/> = The <i>Coolant Temperature</i> measurement is used for the <i>Coolant Temperature Control</i> .

**Engine CAN Termination**

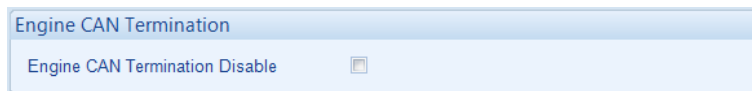

Parameter	Description
Engine CAN Termination Disable	<input type="checkbox"/> = A 120 Ω termination resistor is fitted across the H and L terminals of the ECU port when the unit is powered. <input checked="" type="checkbox"/> = The internal 120 Ω termination resistor is disabled, one must be fitted across the H and L terminals if the module is the first or last on the link.

**Droop**

Parameter	Description
Droop	<p><b>NOTE:</b> Droop options are only available where supported by the Engine ECU (ECM) over the CAN or MODBUS datalink. Contact the engine manufacturer for further details.</p> <p><input type="checkbox"/> = Engine droop is not enabled.  <input checked="" type="checkbox"/> = Where supported by the electronic engine ECU (ECM), the module enables droop in the engine ECU (ECM) governor at the configured percentage.</p>

**SPN Ignore List**

Parameter	Description
SPN Ignore List	<p>Choose the specific SPN for the module to ignore. The module allows the engine to keep running when the ignored SPN occurs; however, depending on the severity, the engine shuts down based on the ECU (ECM) calibration.</p> <p>This is used to mask certain indications or warnings on the ECU (ECM) and not display them on the DSE module.</p>

**Miscellaneous**

Parameter	Description
CAN Source Address (Engine Messages)	Set the <i>CAN Source Address</i> for the DSE module over which other CANbus devices read the alarms.

## 2.8.9 ECU (ECM) ALARMS

**NOTE:** This section is only available when the module is connected to an ECU.

The *ECU (ECM) Alarms* section is subdivided into smaller sections. Select the required section with the mouse.

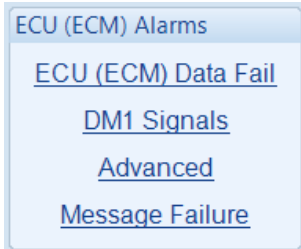

### 2.8.9.1 ECU (ECM) DATA FAIL

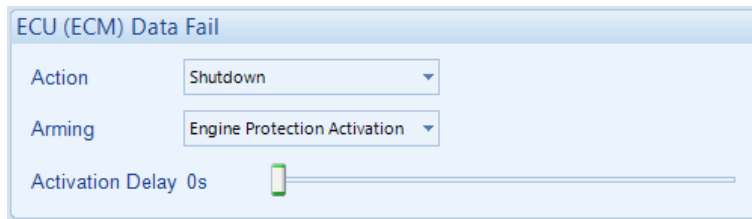

Parameter	Description
ECU (ECM) Data Fail Action	Provides protection against failure of the ECU (ECM) CAN data link.  The alarm action list is as follows, see section entitled <i>Alarm Types</i> for more information: <b>None</b> <b>Electrical Trip</b> <b>Shutdown</b> <b>Warning</b>
Arming	Select when the <i>CAN ECU (ECM) Data Fail</i> alarm is active.  Options are as follows, see the section entitled <i>Alarm Arming</i> elsewhere in this document: <b>Active From Breaker Closed</b> <b>Active From Mains Parallel</b> <b>Always</b> <b>From Safety On</b> <b>From Starting</b> <b>Never:</b> <b>When Stationary</b>
Activation Delay	The amount of time before the module activates the <i>CAN ECU (ECM) Data Fail</i> after a failure.

### 2.8.9.2 DM1 SIGNALS

**NOTE:** Configuration of parameters in this section only has effect when the ECU (ECM) supports these features.

**NOTE:** Configuration of the *Alarm Action* in this section defines the DSE module response to the CAN message; however, the ECU (ECM) still shuts down the engine depending on the alarm severity.

DM1 signals are messages from the CAN (ECM) ECU. The following parameters allows configuration of how the DSE module responds to these messages.

#### ECU Amber

The screenshot shows a configuration window titled "ECU Amber". It contains three settings:

- Action:** A dropdown menu currently set to "Warning".
- Arming:** A dropdown menu currently set to "Always".
- Activation Delay:** A slider control set to "0s".

Parameter	Description
ECU Amber Action	The action the DSE module takes when receiving and ECU Amber fault condition. The alarm action list is as follows, see section entitled <i>Alarm Types</i> for more information: <b>None</b> <b>Electrical Trip</b> <b>Shutdown</b> <b>Warning</b>
Arming	Select when the DSE module activates it <i>ECU Amber</i> alarm. Options are as follows, see the section entitled <i>Alarm Arming</i> elsewhere in this document: <b>Active From Breaker Closed</b> <b>Active From Mains Parallel</b> <b>Always</b> <b>From Safety On</b> <b>From Starting</b> <b>Never:</b> <b>When Stationary</b>
Activation Delay	The amount of time before the module activates the <i>ECU Amber</i> alarm after a receiving an ECU Amber fault condition from the ECU.

**ECU Red**

The screenshot shows a configuration window titled "ECU Red". It contains three settings:

- Action:** A dropdown menu currently showing "Shutdown".
- Arming:** A dropdown menu currently showing "From Safety On".
- Activation Delay:** A slider control set to "0s".

Parameter	Description
ECU Red Action	The action the DSE module takes when receiving an ECU Red fault condition. The alarm action list is as follows, see section entitled <i>Alarm Types</i> for more information: <b>None</b> <b>Electrical Trip</b> <b>Shutdown</b> <b>Warning</b>
Arming	Select when the DSE module activates its <i>ECU Red</i> alarm. Options are as follows, see the section entitled <i>Alarm Arming</i> elsewhere in this document: <b>Active From Breaker Closed</b> <b>Active From Mains Parallel</b> <b>Always</b> <b>From Safety On</b> <b>From Starting</b> <b>Never:</b> <b>When Stationary</b>
Activation Delay	The amount of time before the module activates the <i>ECU Red</i> alarm after receiving an ECU Red fault condition from the ECU.

**ECU Malfunction**

**ECU Malfunction**

Action Warning

Arming Always

Activation Delay 0s

Parameter	Description
ECU Malfunction Action	The action the DSE module takes when receiving an ECU Malfunction fault condition. The alarm action list is as follows, see section entitled <i>Alarm Types</i> for more information: <b>None</b> <b>Electrical Trip</b> <b>Shutdown</b> <b>Warning</b>
Arming	Select when the DSE module activates its <i>ECU Malfunction</i> alarm. Options are as follows, see the section entitled <i>Alarm Arming</i> elsewhere in this document: <b>Active From Breaker Closed</b> <b>Active From Mains Parallel</b> <b>Always</b> <b>From Safety On</b> <b>From Starting</b> <b>Never:</b> <b>When Stationary</b>
Activation Delay	The amount of time before the module activates the <i>ECU Malfunction</i> alarm after receiving an ECU Malfunction fault condition from the ECU.

**ECU Protect**

The screenshot shows a configuration window titled "ECU Protect". It contains three settings:

- Action:** A dropdown menu currently set to "Warning".
- Arming:** A dropdown menu currently set to "From Safety On".
- Activation Delay:** A slider bar set to "0s".

Parameter	Description
ECU Protect Action	The action the DSE module takes when receiving an ECU Protect fault condition. The alarm action list is as follows, see section entitled <i>Alarm Types</i> for more information: <b>None</b> <b>Electrical Trip</b> <b>Shutdown</b> <b>Warning</b>
Arming	Select when the DSE module activates its <i>ECU Protect</i> alarm. Options are as follows, see the section entitled <i>Alarm Arming</i> elsewhere in this document: <b>Active From Breaker Closed</b> <b>Active From Mains Parallel</b> <b>Always</b> <b>From Safety On</b> <b>From Starting</b> <b>Never:</b> <b>When Stationary</b>
Activation Delay	The amount of time before the module activates the <i>ECU Protect</i> alarm after receiving an ECU Protect fault condition from the ECU.

### 2.8.9.3 ADVANCED

#### DPTC Filter

Parameter	Description
DPTC Filter Enabled	<p><input type="checkbox"/> = The DSE module's <i>DPTC Filter</i> alarm is disabled, it does not act upon any DPTC Filter fault conditions from the ECU.</p> <p><input checked="" type="checkbox"/> = The DSE module's <i>DPTC Filter</i> alarm is enabled. The action the DSE module takes when receiving a DPTC Filter fault condition from the ECU. The alarm action list is as follows, see section entitled <i>Alarm Types</i> The alarm action list is as follows, see section entitled <i>Alarm Types</i> for more information:</p> <p><b>Electrical Trip</b>  <b>Indication</b>  <b>Shutdown</b>  <b>Warning</b></p>
Arming	<p>Select when the DSE module activates its <i>DPTC Filter</i> alarm. Options are as follows, see the section entitled <i>Alarm Arming</i> elsewhere in this document:</p> <p><b>Always</b>  <b>From Safety On</b>  <b>From Starting</b></p>

#### HEST Active

Parameter	Description
HEST Active Enabled	<p><input type="checkbox"/> = The DSE module's <i>HEST</i> alarm is disabled, it does not act upon any HEST fault conditions from the ECU.</p> <p><input checked="" type="checkbox"/> = The DSE module's <i>HEST</i> alarm is enabled. The action the DSE module takes when receiving a HEST fault condition from the ECU. The alarm action list is as follows, see section entitled <i>Alarm Types</i> The alarm action list is as follows, see section entitled <i>Alarm Types</i> for more information:</p> <p><b>Indication</b>  <b>Warning</b></p>
Arming	<p>Select when the DSE module activates its <i>HEST</i> alarm. Options are as follows, see the section entitled <i>Alarm Arming</i> elsewhere in this document:</p> <p><b>Always</b>  <b>From Safety On</b>  <b>From Starting</b></p>

Parameter descriptions are continued overleaf...

**DEF Level**

Parameter	Description
DEF Level Enabled	<p><input type="checkbox"/> = The DSE module's <i>DEF Level</i> alarm is disabled, it does not act upon any DEF Level fault conditions from the ECU.</p> <p><input checked="" type="checkbox"/> = The DSE module's <i>DEF Level</i> alarm is enabled. The action the DSE module takes when receiving a DEF Level fault condition from the ECU. The alarm action list is as follows, see section entitled <i>Alarm Types</i> The alarm action list is as follows, see section entitled <i>Alarm Types</i> for more information:</p> <p><b>Electrical Trip</b>  <b>Shutdown</b>  <b>Warning</b></p>
Arming	<p>Select when the DSE module activates its <i>DEF Level</i> alarm. Options are as follows, see the section entitled <i>Alarm Arming</i> elsewhere in this document:</p> <p><b>Always</b>  <b>From Safety On</b>  <b>From Starting</b>  <b>Loading Alarms Activation</b>  <b>Never:</b>  <b>When Stationary</b></p>
Activation Delay	<p>The amount of time before the module activates the <i>DEF Level</i> alarm after a receiving a DEF Level fault condition from the ECU.</p>

**SCR Inducement**

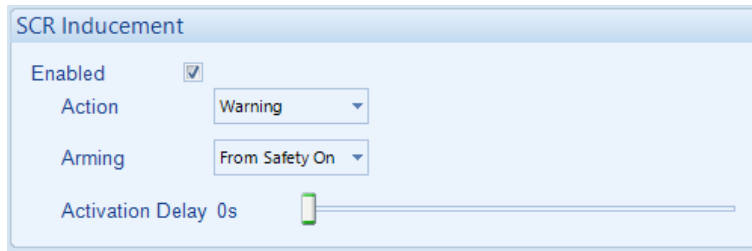

Parameter	Description
SCR Inducement Enabled	<p><input type="checkbox"/> = The DSE module's <i>SCR Inducement</i> alarm is disabled, it does not act upon any SCR Inducement fault conditions from the ECU.</p> <p><input checked="" type="checkbox"/> = The DSE module's <i>SCR Inducement</i> alarm is enabled. The action the DSE module takes when receiving a SCR Inducement fault condition from the ECU.</p> <p>The alarm action list is as follows, see section entitled <i>Alarm Types</i> The alarm action list is as follows, see section entitled <i>Alarm Types</i> for more information:</p> <p><b>Electrical Trip</b>  <b>Shutdown</b>  <b>Warning</b></p>
Arming	<p>Select when the DSE module activates its <i>SCR Inducement</i> alarm. Options are as follows, see the section entitled <i>Alarm Arming</i> elsewhere in this document:</p> <p><b>Always</b>  <b>From Safety On</b>  <b>From Starting</b>  <b>Loading Alarms Activation</b>  <b>Never:</b>  <b>When Stationary</b></p>
Activation Delay	<p>The amount of time before the module activates the <i>SCR Inducement</i> alarm after a receiving a SCR Inducement fault condition from the ECU.</p>

### 2.8.9.4 MESSAGE FAILURE

Allows adjustment of the CAN message failure rate for instrumentation parameters received from the ECU (ECM). This is to allow for spurious CAN data loss error message caused by longer than usual timeouts.

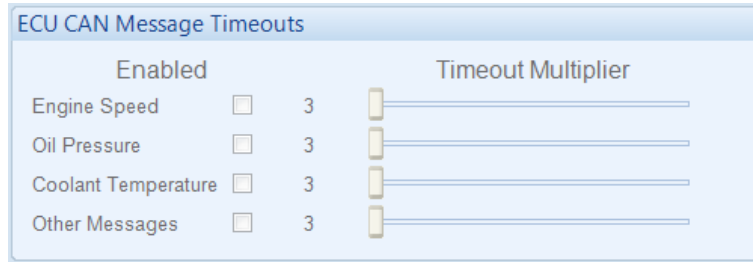

Parameter	Description
Message Failure	<p><input type="checkbox"/> = The message failure monitoring works on the default setting as specified by the manufacturer.</p> <p><input checked="" type="checkbox"/> = When enabled, this option overrides the standard message timeout with a longer timeout to avoid spurious failures. Set the <i>Timeout Multiplier</i> to adjust the timeout value for the parameter by between three and ten times the standard value.</p>

### 2.8.10 GAS ENGINE OPTIONS

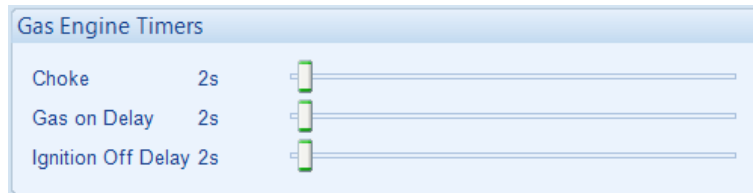

Parameter	Description
Choke Timer	Controls the amount of time that the Gas Choke output is active during the starting sequence.
Gas On Delay	Controls the amount of time between energising the Gas Ignition and energising the Fuel output. Used in the starting sequence to purge old gas from the engine.
Ignition Off Delay	Controls the amount of time between de-energising the Fuel output and de-energising the Gas Ignition output. Used in the stopping sequence to purge unburnt gas from the engine before it is stopped.

## 2.8.11 CRANKING

Cranking settings are used to detect when the set fires during the starting sequence. As the set is cranked, the first parameter that passes it's *crank disconnect* setting results in the cessation of the cranking signal.

Having more than one *crank disconnect* source allows for a much faster crank disconnect response leading to less wear on the engine and starter components, and provides added safety in case one source is lost, by a blown or tripped fuse for example.

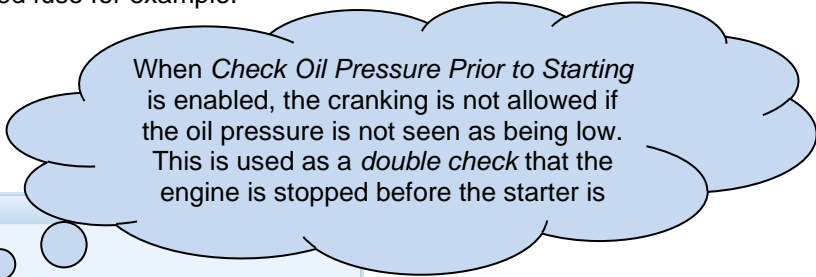

### Options



Parameter	Description
Crank Disconnect on Oil Pressure	<input type="checkbox"/> = The DSE module does not use oil pressure to decide when to disengage the starter motor. <input checked="" type="checkbox"/> = The DSE module does uses oil pressure to decide when to disengage the starter motor in addition to the enabled methods
Check Oil Pressure Prior to Starting	<input type="checkbox"/> = The DSE module does not use oil pressure as an indication if the engine is running. This is disabled for large engines that have an electrical oil pump which is used to maintain oil pressure even when the engine is stationary. <input checked="" type="checkbox"/> = The DSE module uses oil pressure as an indication if the engine is running.

### Crank Disconnect

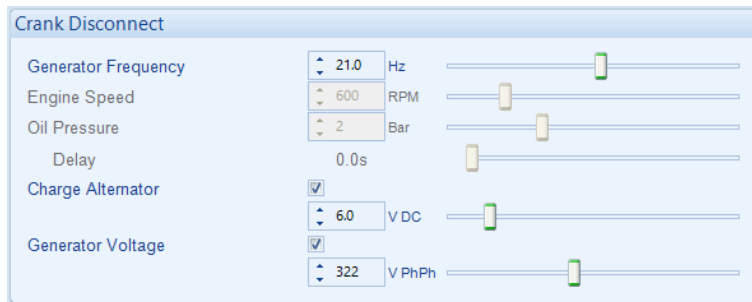

Parameter	Description
Generator Frequency	The DSE module disengages the starter motor when the generator frequency rises above the configured level.
Engine Speed	The DSE module disengages the starter motor when the engine speed rises above the configured level.
Oil Pressure	The DSE module disengages the starter motor when the engine oil pressure rises above the configured level for longer than the configured <i>Delay</i> .
Charge Alternator	<input type="checkbox"/> = The DSE module does not use charge alternator voltage to decide when to disengage the starter motor. <input checked="" type="checkbox"/> = The DSE module disengages the starter motor when the charge alternator voltage rises above the configured level.
Generator Voltage	<input type="checkbox"/> = The DSE module does not use generator voltage to decide when to disengage the starter motor. <input checked="" type="checkbox"/> = The DSE module disengages the starter motor when the generator voltage rises above the configured level.

**Manual Crank**

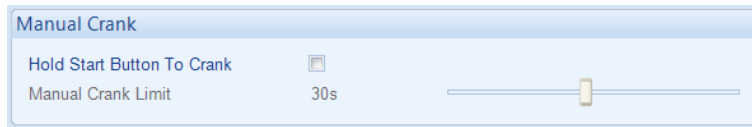

Parameter	Description
Hold Start Button to Crank	<input type="checkbox"/> = When in manual mode, pressing the start button momentarily instructs the generator to go through its cranking procedure. <input checked="" type="checkbox"/> = Releasing the start button during a manual start also disconnects the crank. Manual Crank Limit is provided to protect the engine from being cranked too long in case of a start failure.

## 2.8.12 IDLE SETTING

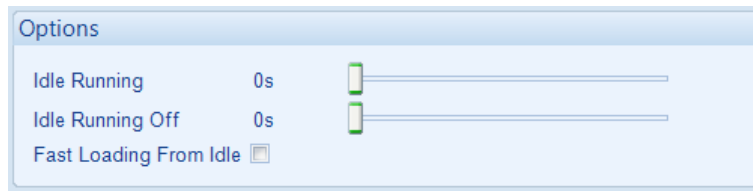

Options	Description
Idle Running	The amount of time that the engine is requested to run at idle speed upon starting. This is typically used to limit emissions at start-up.
Idle Running Off	The amount of time that the engine takes to run up to rated speed after removal of the command to run at idle speed. If this time is too short, the engine is stopped due to an <i>Underspeed</i> alarm. If the time is too long, <i>Underspeed</i> protection is disabled until the <i>Smoke Limit Time Off</i> time has expired.
Fast Loading From Idle	<input type="checkbox"/> = The DSE module waits for the <i>Idle Running Off</i> time to expire, then loads the generator. <input checked="" type="checkbox"/> = During the <i>Idle Running Off</i> time if the <i>Loading Voltage</i> and <i>Loading Frequency</i> are reached, the module terminates the <i>Idle Running Off</i> and loads the generator.

### 2.8.13 SPEED SENSING

Options

Disable ECM Speed Sensing

Magnetic Pickup Fitted

Flywheel Teeth

Enable Multiple Engage Attempts

Engage Attempts

Loss of Sensing Signal

Disable under speed alarms if sensor fails

Magnetic Pickup Open Circuit

Parameter	Description
Disable ECM Speed Sensing	<input type="checkbox"/> = An ECM is connected to the DSE module and being used for speed sensing. <input checked="" type="checkbox"/> = An ECM is connected to the DSE module but another form of speed sensing fitted to the DSE module is being used.
Magnetic Pickup Fitted	<div style="border: 3px double black; padding: 5px;"> <p><b>NOTE: For more detailed information on the Magnetic Pickup Specification, refer to DSE Publication: 057-254 DSE8610 MKII Operator Manual.</b></p> </div> <input type="checkbox"/> = Magnetic pickup device is not connected to the DSE module. <input checked="" type="checkbox"/> = A low impedance magnetic pickup device is connected to the DSE module to measure engine speed.
Flywheel Teeth	Define the number of pulses which are counted by the speed sensing device in each engine revolution.
Enable Multiple Engage Attempts	<input type="checkbox"/> = No engage attempt is given. If no speed sensing is detected during cranking, the <i>Fail To Start</i> alarm is active. <input checked="" type="checkbox"/> = If no magnetic pickup pulses are detected during cranking, it is assumed that the starter has not engaged to turn the engine. The starter is withdrawn and re-engaged for the configured number of <i>Engage Attempts</i> .
Loss of Sensing Signal	If the speed sensing signal is lost during engine running (or not present during cranking when <i>Multiple Engage Attempts</i> is enabled), an alarm is generated: <b>Shutdown Warning</b>
Disable Under Speed Alarms If Sensor Fails	<input type="checkbox"/> = Under speed alarms activate even if speed sensor has failed. <input checked="" type="checkbox"/> = Under speed alarms are disabled when the speed sensor fails.
Magnetic Pickup Open Circuit	If the magnetic pickup device is not detected, an alarm is generated: <b>Shutdown Warning Always Latched</b>

## 2.8.14 SPEED SETTINGS

### Under Speed

Parameter	Description
Under Speed Alarm	<input type="checkbox"/> = <i>Under Speed</i> alarm is disabled <input checked="" type="checkbox"/> = Under Speed gives an alarm in the event of the engine speed falling below the configured <i>Under Speed Alarm Trip</i> value for longer than the <i>Generator Transient Delay</i> . The <i>Underspeed Alarm Trip</i> value is adjustable to suit user requirements.
Action	Select the type of alarm required from the list: <b>Electrical Trip</b> <b>Shutdown</b>  For details of these, see the section entitled <i>Alarm Types</i> elsewhere in this document.
Under Speed Pre-Alarm	<input type="checkbox"/> = <i>Under Speed Warning</i> alarm is disabled <input checked="" type="checkbox"/> = Under Speed gives a warning alarm in the event of the engine speed falling below the configured <i>Under Speed Pre-Alarm Trip</i> value for longer than the <i>Generator Transient Delay</i> . Once the engine speed rises above the <i>Under Speed Pre-Alarm Return</i> the alarm is reset. The <i>Under Speed Pre-Alarm Trip</i> value is adjustable to suit user requirements.

Parameter descriptions are continued overleaf...

**Over Speed**

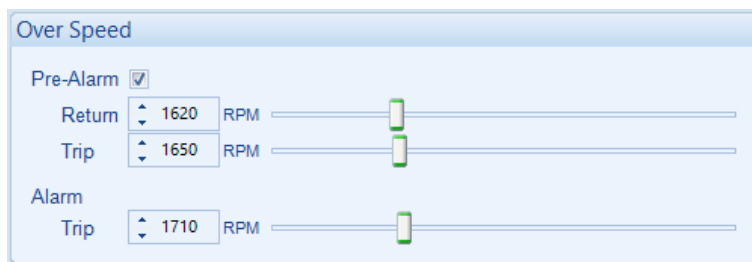

Parameter	Description
Over Speed Pre-Alarm	<input type="checkbox"/> = Alarm is disabled <input checked="" type="checkbox"/> = Over Speed gives a warning alarm in the event of the engine speed rising above the configured <i>Over Speed Pre-Alarm Trip</i> value for longer than the <i>Generator Transient Delay</i> . The <i>Warning</i> is automatically reset when the engine speed falls below the configured <i>Return</i> level. The <i>Over Speed Pre-Alarm Trip</i> value is adjustable to suit user requirements.
Over Speed Alarm	Over Speed gives a <i>Shutdown</i> alarm in the event of the engine speed rising above the configured <i>Over Speed Alarm Trip</i> value for longer than the <i>Generator Transient Delay</i> . The <i>Over Speed Alarm Trip</i> value is adjustable to suit user requirements.

**Overspeed Options**

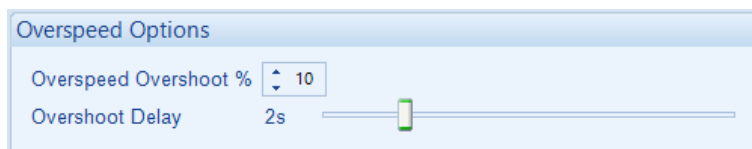

Parameter	Description
Overspeed Overshoot %	To prevent spurious overspeed alarms at engine start up, the module includes configurable <i>Overspeed Overshoot</i> protection. This allows the engine speed to 'overshoot' the Overspeed setting during the starting process for a short time.
Overshoot Delay	Rather than 'inhibiting' the Overspeed alarms, the levels are temporarily raised by the <i>Overspeed Overshoot %</i> for the duration of the <i>Overspeed Overshoot</i> delay from starting.

## 2.8.15 PLANT BATTERY

### Voltage Alarms

Parameter	Description
Plant Battery Under Voltage IEEE 37.2 -27 DC Undervoltage Relay	<input type="checkbox"/> = The alarm is disabled. <input checked="" type="checkbox"/> = The alarm activates when the battery voltage drops below the configured <i>Pre-Alarm</i> level for the configured <i>Delay</i> time. When the battery voltage rises above the configured <i>Return</i> level, the alarm is deactivated.
Plant Battery Over Voltage IEEE 37.2 -59 DC Overvoltage Relay	<input type="checkbox"/> = The alarm is disabled. <input checked="" type="checkbox"/> = The alarm activates when the battery voltage rises above the configured <i>Pre-Alarm</i> level for the configured <i>Delay</i> time. When the battery voltage drops below the configured <i>Return</i> level, the alarm is deactivated.

### Charge Alternator Alarms

Parameter	Description
Use Module For Charge Alternator	<div style="border: 1px solid black; padding: 5px; margin-bottom: 5px;"> <p><b>NOTE: The feature is only available when an electronic engine is selected.</b></p> </div> <input type="checkbox"/> = DSE module measures the charge alternator voltage. <input checked="" type="checkbox"/> = Engine ECU (ECM) provides charge alternator voltage.
Charge Alternator Alarm	<input type="checkbox"/> = The alarm is disabled. <input checked="" type="checkbox"/> = The alarm activates when the charge alternator voltage falls below the configured <i>Trip</i> level for the configured <i>Delay</i> time.
Charge Alternator Pre-Alarm	<input type="checkbox"/> = The alarm is disabled. <input checked="" type="checkbox"/> = The alarm activates when the charge alternator voltage falls below the configured <i>Trip</i> level for the configured <i>Delay</i> time.

## 2.8.16 INLET TEMPERATURE

Provides inlet temperature alarms when the module is used in conjunction with electronic (ECU) engines that support the reading of inlet temperature.

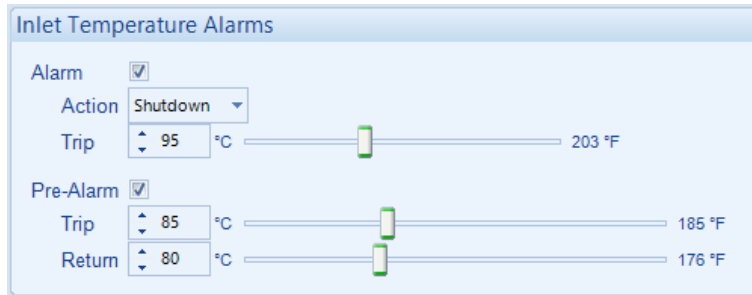

Parameter	Description
Inlet Temperature Alarm	<p><b>NOTE:</b> The feature is only available when an electronic engine is selected.</p> <p><input type="checkbox"/> = Disable the alarm  <input checked="" type="checkbox"/> = <i>Inlet Temperature Alarm</i> is activated when the <i>Inlet Temperature</i> sent from the ECU rise above the <i>Trip</i> level.</p>
Action	<p>Select the type of alarm required from the list:</p> <p><b>Electrical Trip</b>  <b>Shutdown</b></p> <p>For details of these, see the section entitled <i>Alarm Types</i> elsewhere in this document.</p>
Inlet Temperature Pre-Alarm	<p><input type="checkbox"/> = The alarm is disabled.  <input checked="" type="checkbox"/> = <i>Inlet Temperature Pre-Alarm</i> is activated when the <i>Inlet Temperature</i> sent from the ECU is above the configured <i>Trip</i> level The Pre-Alarm is deactivated when the <i>Inlet Temperature</i> falls below the <i>Return</i> level.</p>

## 2.8.17 ENGINE ICON DISPLAYS

This section is used with Electronic Engines, it allows to create or define a CAN Lamp icon and how to be displayed when the configured alarm or message is active, such as flashing the CAN icon rapidly or slowly. The first screen is enabled by default and it cannot be disabled, the second and third screens are configurable to be enabled or disabled through this section to allow the user create more CAN Icon Displays. The CAN icon instrument is activated based on a DTC message sent from the ECU or according to GenComm instrumentation conditions.

The screenshot shows the 'Engine Icon Displays' configuration window. On the left, there are three categories of displays: 'EPA Icons', 'DPF Regeneration', and 'SCR-DEF Lamps'. Each category shows a preview of the display with various icons. The 'DEF Tank Level #### %' display is highlighted in red. On the right, the configuration fields are: 'Title' (set to 'DEF Tank Level'), 'Title Instrumentation' (set to 'DEF Tank Level (numeric)'), and a 'Display' section with a checked 'Display On Module' checkbox.

**Provide the Title of the relevant**

**Select the display method to show the DEF Tank Level next to the Title. Details found in below section. Options are:**  
 Not Used  
 DEF Tank Level (gauge)  
 DEF Tank Level (numeric)

**Select the required screen with the mouse to configure, then tick the Display box to enable the screen on the module.**



**Display**  
 Display On Module

**An example showing a customised EPA icon when the screen is enabled.**

**DPF Regeneration Lamps**

### 2.8.17.1 TITLE INSTRUMENTATION

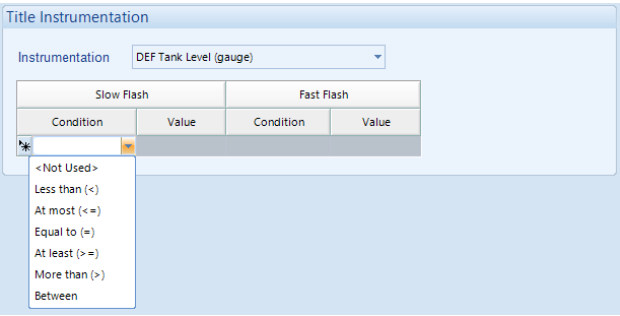
Select the display form of the DEF Tank Level instrument in the relevant screen.







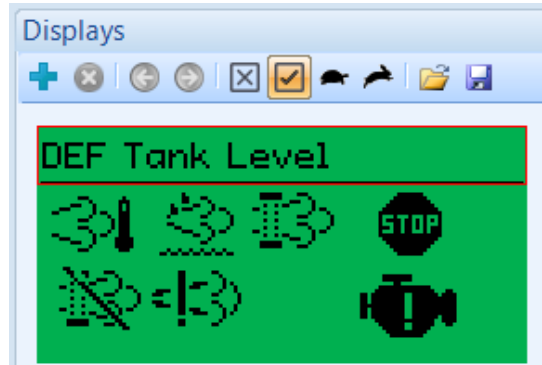

Title Instrumentation	Display
Not Used	The <i>DEF Tank Level</i> is not displayed in the title of the screen.
DEF Tank Level (Gauge)	<p>The <i>DEF Tank Level</i> is displayed in form of bargauge meter </p> <p>The DEF Tank Level (gauge) display is flashed slowly or rapidly on the screen if the conditions and values are configured and the instrument readings are satisfied.</p> 
DEF Tank Level (numeric)	The <i>DEF Tank Level</i> is displayed in numeric form 

## 2.8.17.2 ICON INSTRUMENTATION

### Displays

Select the required Lamp Icon from the screen to configure, or click on the  tab to create a new Lamp Icon.



Display tab tools	Description
	Click on the Plus tab to create a new Lamp Icon within the selected screen.
	Click on the delete tab to delete the selected Lamp Icon from the screen.
	Click on the right or left tab to select the next Lamp Icon in the screen.
	Click to hide the instruments from the screens.
	Click to show all the instruments in the screens.
	This tool is for flashing demonstration. Click to flash all the instruments slowly.
	This tool is for flashing demonstration. Click to flash all the instruments rapidly.
	Click to import a saved <i>Engine Icon Displays</i> .
	Click to export the configured <i>Engine Icon Displays</i> .

### Icon Bitmaps

Configure the Icon Bitmaps of the selected instrument from the screen, to show the Lamp Icon when it is active or inactive











Indicates the selected Icon to show when the instrument is active and the module is flashing it on.

Click on  to delete the icon.

Click to select the Lamp Icon. The available icons are listed in the below table.

Icon Bitmaps	Description
Flash On (On)	Select the icon to show when the instrument is active and the module has flashed on the <i>Engine Icons</i> on the screen.
Flash Off	Select the icon to show when the instrument is active and the module has flashed off the <i>Engine Icons</i> on the screen.
Off	Select the icon to show when the instrument is not active on the screen.
Position X, Y	Configure the instrument positions for X & Y coordinates on the screen.

Continued Overleaf...

Lamp Icons	Display
	DEF On Large
	DEF On
	DPF Active
	DPF Inhibit
	DPF Stop
	DPF Warning
	ECU Red Alarm
	ECU Yellow Alarm
	HEST On
	SCR Active Large
	SCR Active

### Icon Instrumentation

Configure the Type of the Instrumentation to read from the DTC or from a GenComm register, and on what condition(s) the selected instrument to be On or flashing.

#### Icon Instrumentation DTC Type

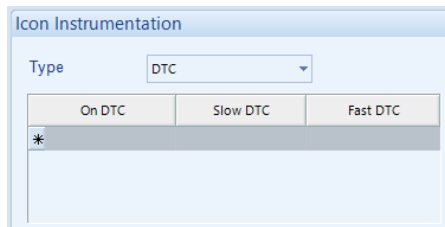

Icon Instrumentation	Description
On DTC	Configure the DTC code to activate the instrument when <i>On DTC</i> satisfied.
Slow DTC	Configure the DTC code to flash the instrument slowly when <i>Slow DTC</i> satisfied.
Fast DTC	Configure the DTC code to flash the instrument rapidly when <i>Fast DTC</i> satisfied.

#### Icon Instrumentation GenComm Type

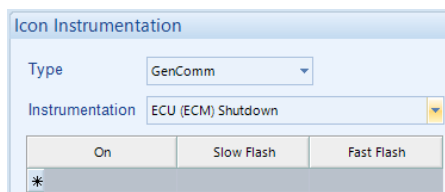

Parameters detailed overleaf...

Editing the Configuration

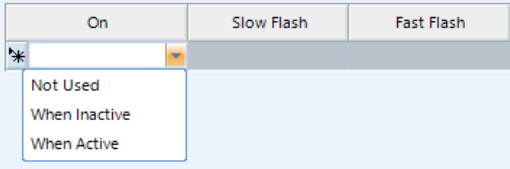
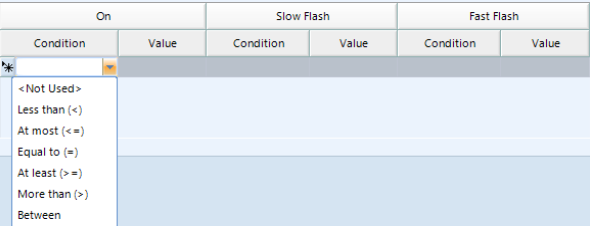
Icon Instrumentation	Description
Instrumentation	Select the instrument to monitor. This could be a flag condition or an instrumentation value.
Flag type of GenComm Icon Instrument	<p>Select the required Condition to activate the Instrumentation Icon, or to Slow Flash, or to Fast Flash based on the options below:</p> <p><i>Not Used</i>  <i>When Inactive</i>  <i>When Active</i></p> 
Instrumentation type of GenComm Icon Instrument	<p>Configure the required Condition to activate the Instrumentation Icon, or to Slow Flash, or to Fast Flash.</p> 

## 2.9 COMMUNICATIONS

The *Communications* page is subdivided into smaller sections. Select the required section with the mouse.

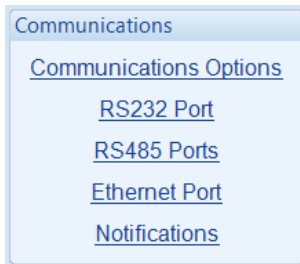

### 2.9.1 COMMUNICATIONS OPTIONS

Provides a means of giving the controller an identity. This is used in the SCADA section to allow the operator to see the site name and engine identity that it is currently connected to.

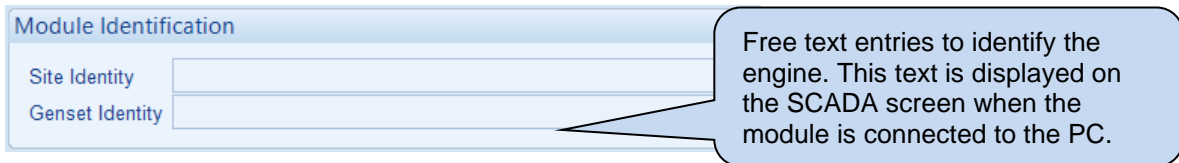

Parameter	Description
Site Identity	A free entry boxes to allow the user to give the DSE module a description of where the site is located. This text is not shown on the module's display and is only seen when performing remote communication. This aids the user in knowing where the generator is located.
Genset Identity	A free entry boxes to allow the user to give the DSE module a description of which generator it is connected to. This text is not shown on the module's display and is only seen when performing remote communication. This aids the user in knowing which generator on a specific site is being monitored.

## 2.9.2 RS232 PORT

The *RS232 Port* page is subdivided into smaller sections. Select the required section with the mouse.

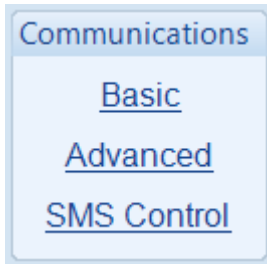

2.9.2.1 BASIC

Serial Port Configuration

**NOTE:** Connecting a modem directly to the module’s RS232 for is legacy support only. When a new installation requires remote communication using the cellular network is required, refer to DSE products DSE890, DSE891 and DSEWebNet on the DSE website: [www.deepseaelectronics.com](http://www.deepseaelectronics.com).

**NOTE:** When the *RS232 Port Usage* is configured to “*PLC Comms*”, the transmitting module’s *Port Usage* must be configured to “*Gencomm*”. This allows the module configured as “*PLC Comms*” act as a master and read from the module configured to “*Gencomm*”. Every device on the RS232 link must have an individual *Slave ID*. For details on how to configure the *PLC Editor* to read via its RS232, refer to DSE Publication: *057-314 Advanced PLC Software Manual* which is found on our website: [www.deepseaelectronics.com](http://www.deepseaelectronics.com)

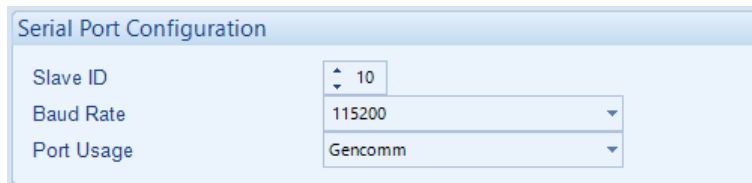

Parameter	Description
Slave ID	Select the Slave ID of the DSE module’s RS232 port.
Baud Rate	Select the Baud Rate (speed of communication) of the DSE module’s RS232 port. Every device on the RS232 link must have the same Baud Rate. <b>1200</b> <b>2400</b> <b>4800</b> <b>9600</b> <b>14400</b> <b>19200</b> <b>28800</b> <b>38400</b> <b>57600</b> <b>115200</b>
Port Usage	<p><b>NOTE:</b> In a system for a <i>PLC Comms</i> application, only one DSE module must be configured to act as the PLC master. For further details and instructions on using <i>the PLC Comms</i>, refer to DSE Publication: <i>057-314 Advanced PLC Software Manual</i> which is found on our website: <a href="http://www.deepseaelectronics.com">www.deepseaelectronics.com</a></p> <p><b>Gencomm:</b> RS232 port is used for direct RS232 connection to PLC, BMS etc  <b>Incoming Modem Calls:</b> RS232 port connected to modem, used to accept incoming calls from a PC only.  <b>Incoming And Outgoing Modem (Sequence):</b> RS232 port connected to modem used to accept incoming calls from a PC and also make calls upon events. When multiple <i>Alarm Numbers</i> are configured, the module attempts to dial each number. When the dial out call fails to one of the configured numbers, the module attempts to call that number for the configured number of <i>Retries</i>, before it carries on to the next number.</p>

Parameter descriptions are continued overleaf...

Parameter	Description
Port Usage	<p><b>Incoming And Outgoing Modem (Cyclic):</b> RS232 port connected to modem used to accept incoming calls from a PC and also make calls upon events. When multiple <i>Alarm Numbers</i> are configured, the module attempts to dial each number. When the dial out call fails to one of the configured numbers, the module completes the cycle and re-attempts to call those numbers for the configured number of <i>Retries</i>.</p> <p><b>Outgoing Modem Alarms (Sequence):</b> RS232 port connected to modem, used to make calls upon events. When multiple <i>Alarm Numbers</i> are configured, the module attempts to dial each number. When the dial out call fails to one of the configured numbers, the module attempts to call that number for the configured number of <i>Retries</i>, before it carries on to the next number.</p> <p><b>Outgoing Modem Alarms (Cyclic):</b> RS232 port connected to modem, used to make calls upon events. When multiple <i>Alarm Numbers</i> are configured, the module attempts to dial each number. When the dial out call fails to one of the configured numbers, the module completes the cycle and re-attempts to call those numbers for the configured number of <i>Retries</i>.</p> <p><b>PLC Comms:</b> RS232 port is used to read the connected controller's registers over the RS232 which are defined in the <i>PLC Editor</i>.</p>

**Modem Settings**

**NOTE:** Connecting a modem directly to the module's RS232 for is legacy support only. When a new installation requires remote communication using the cellular network is required, refer to DSE products DSE890, DSE891 and DSEWebNet on the DSE website: [www.deepseaelectronics.com](http://www.deepseaelectronics.com).

Parameter	Description
Alarm Numbers	The phone number that the module dials upon an event. This number must be connected to a PC modem on a PC running the DSE Configuration Suite Software. Leave this field empty when dial-out to a PC is not required.
GSM Modem	<input type="checkbox"/> = The connected modem is a fixed line telephone modem <input checked="" type="checkbox"/> = The connected modem is a GSM (cellular) modem. The GSM signal strength meter and GSM operator are shown on the module display.
SMS Message Centre Number	The Message centre used to send SMS messages. This number is obtained from the GSM operator.
SMS Recipient Numbers	Numbers of the cell phones to send SMS messages to. Leave blank if SMS function is not required.
Send Extended Instrumentation	<input type="checkbox"/> = The SMS message that is sent only contains information about the event. <input checked="" type="checkbox"/> = When the module sends an SMS message for an event, it also contains information about the generator (such as oil pressure) at the time the event occurred.
Send as Flash Message	<input type="checkbox"/> = The type of SMS message that is sent is standard. <input checked="" type="checkbox"/> = The type of SMS message that is sent is a flash message. A flash SMS is a type of message that without user action appears directly and full screen on the phone.

### 2.9.2.2 ADVANCED

**NOTE:** Connecting a modem directly to the module's RS232 for is legacy support only. When a new installation requires remote communication using the cellular network is required, refer to DSE products DSE890, DSE891 and DSEWebNet on the DSE website: [www.deepseaelectronics.com](http://www.deepseaelectronics.com).

#### Initialisation Strings

Initialisation Strings	
Init (not auto answer)	E0S7=60S0=0&S0&C1&D3
Init (auto answer)	E0S7=60S0=2&S0&C1&D3
Hangup	H0

The initialisation strings are commands that are sent to the modem upon powering up the DSE module and additionally at regular intervals subsequently, whenever the DSE module *Initialises* (resets) the modem.

#### Factory Set Initialisation Strings

Parameter	Description
E0	Echo off
S7=60	Wait for carrier time 60s
S0=0 (not auto answer)	Do not answer
S0=2 (auto answer)	Answer after two rings
&S0	DSR always on
&C1	DCD is active if modem is online
&D3	Reset (ATZ) on DTR-drop
H0	Hang up (disconnect)

#### Silent Operation

The modem connected to the DSE controller usually makes dialling noises and 'squeal' in the initial stages of making a data call. To control this noise, add the following command to the end of the initialisation string:

Parameter	Description
M0	Silent operation
M1	Sounds during the initial stages of making a data call
M2	Sounds always when connected (not recommended for troubleshooting)

### Sierra/Wavecom Fastrak Supreme GSM Modem Initialisation Strings

When connected to the Wavecom Fastrak Supreme GSM modem, the initialisation strings must be altered by changing the factory set &D3 to &D2.

Initialisation Strings	
Init (not auto answer)	E057=6050=0&S0&C1&D2
Init (auto answer)	E057=6050=2&S0&C1&D2
Hangup	H0

Parameter	Description
&D2 (required for Sierra / Wavecom Fastrak Supreme)	Hang up on DTR-drop
&D3 (DSE module factory settings)	Reset on DTR-drop

### Other Modems

When using modems not recommended by DSE, first try either of the options shown above. If problems are still encountered, contact your modem supplier for further advice.

### Connection Settings

Connection Settings	
Master inactivity timeout	5s
Connect delay	60s
Retries	4
Retry delay	5s
Repeat cycle delay	10s
Inter-frame delay	0 ms

Parameter	Description
Master Inactivity Timeout	The module monitors by default the USB port for communications. When activity is detected on the RS232 port, the module monitors the port for further data. If no data activity is detected on the port for the duration of the <i>Master Inactivity Timer</i> , it reverts to looking at the USB port. This needs to be set longer than the time between Modbus polls from the master.
Connect Delay	The amount of time that is allowed to elapse between the alarm being registered and the controller dialling out with the fault.
Retries	The number of times the module attempts to contact the remote PC by modem.
Retry Delay	The amount of time between retries
Repeat Cycle Delay	The amount of time between the cycle repeats when dialling out calls to multiple <i>Alarm Numbers</i> fails.
Inter-frame Delay	Set the time delay between the DSE module receiving a MODBUS RTU request and the DSE module's response.

2.9.2.3 SMS CONTROL

**NOTE:** Connecting a modem directly to the module's RS232 for is legacy support only. When a new installation requires remote communication using the cellular network is required, refer to DSE products DSE890, DSE891 and DSEWebNet on the DSE website: [www.deepseaelectronics.com](http://www.deepseaelectronics.com).

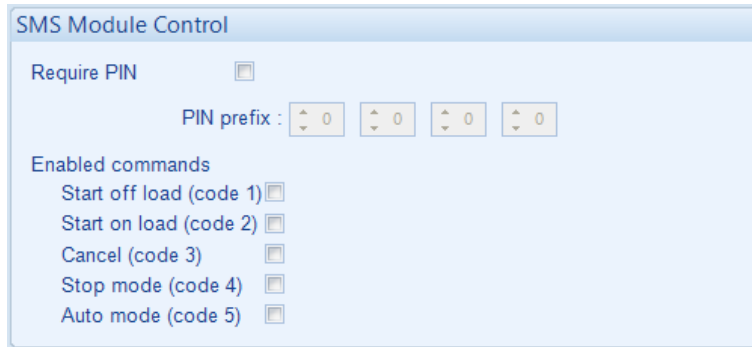

Parameter	Description
Require PIN	<input type="checkbox"/> = A control code sent by SMS does not require a PIN code entered before the code. <input checked="" type="checkbox"/> = For security, the configured <i>PIN Prefix</i> must be entered in the SMS prior to the control code.
Start Off Load (Code 1)	<input type="checkbox"/> = Sending code 1 to the module via SMS does not issue a <i>Start Off Load</i> command. <input checked="" type="checkbox"/> = When in Auto mode, the module performs the start sequence but the engine is not instructed to take the load when code 1 is sent via SMS. This function is used where an engine only run is required e.g. for exercise.
Start On Load (Code 2)	<input type="checkbox"/> = Sending code 2 to the module via SMS does not issue a <i>Start On Load</i> command. <input checked="" type="checkbox"/> = When in auto mode, the module performs the start sequence and transfer load to the engine when code 2 is sent via SMS.
Cancel (Code 3)	<input type="checkbox"/> = Sending code 3 to the module via SMS does not issue a cancel the start command issued by code 1 or 2. <input checked="" type="checkbox"/> = Sending code 3 to the module via SMS cancels the start command issued by code 1 or 2.
Stop Mode (Code 4)	<input type="checkbox"/> = Sending code 4 to the module via SMS does not issue place the unit into its <i>Stop Mode</i> . <input checked="" type="checkbox"/> = Sending code 4 to the module via SMS mimics the operation of the 'Stop' button and is used to provide a remote SMS stop command.
Auto Mode (Code 5)	<input type="checkbox"/> = Sending code 5 to the module via SMS does not issue place the unit into its <i>Auto Mode</i> . <input checked="" type="checkbox"/> = Sending code 5 to the module via SMS mimics the operation of the Auto button.

## 2.9.2.4 TROUBLESHOOTING MODEM COMMUNICATIONS

 **NOTE: Connecting a modem directly to the module's RS232 for is legacy support only. When a new installation requires remote communication using the cellular network is required, refer to DSE products DSE890, DSE891 and DSEWebNet on the DSE website: [www.deepseaelectronics.com](http://www.deepseaelectronics.com).**

### 2.9.2.4.1 MODEM COMMUNICATION SPEED SETTING

First ensure the modem is set to communication with the DSE module at 9600 baud – Modems supplied by DSE are factory adjusted to operate with the DSE module. Only modems purchased from a third party may require adjustment.

To change the modems RS232 baud rate you need a command line terminal program (HyperTerminal by Microsoft is a good solution). Operation of this terminal program is not supported by DSE; contact your terminal program supplier.

Connect the modem RS232 port to your PCs RS232 port. You may need an additional card in your PC to provide this facility.

Use HyperTerminal (or similar) to connect to the modem at its current baud rate. You may need to contact your modem supplier to obtain this detail. If this is not possible, use 'trial and error' methods. Select a baud rate, attempt connection, press <ENTER> a few times. If the modem responds with **OK** then you are connected at the correct baud rate. Any other response (including nothing) means you are not connected so select another baud rate.

When connected, enter the following command:

**AT+IPR=9600** and press <ENTER>  
This sets the modem to 9600 baud.

Close the HyperTerminal connection (**do not** remove power from the modem) then open a new connection to the modem at 9600 baud.

Enter the following command:

**AT&W** and press <ENTER>

This saves the new setting in the modem. Power is now removed. The next time power is applied, the modem starts with the new settings (Baud rate = 9600), suitable to communicate with the DSE module.

### 2.9.2.4.2 GSM MODEM CONNECTION

Most GSM modems have a *Status* LED. The Wavecom Fastrack Supreme as recommended and previously supplied by DSE has a RED Status LED, operating as follows.

LED State	Description
Off	Modem is not powered
On Continuous	Not connected to GSM network
Flashing Slow (approximately once every two seconds)	Connected to GSM network
Flashing Fast (approximately twice per second)	Connected to GSM network data transmission in progress.

### 2.9.3 RS485 PORTS

**NOTE:** When the *RS485 Port Usage* is configured to “*PLC Comms*”, all other modules’ *Port Usage* must be configured to “*Gencomm*”. This allows the module configured as “*PLC Comms*” to act as a master and read from the module(s) configured to “*Gencomm*”. For details on how to configure the *PLC Editor* to read via its RS485, refer to DSE Publication: *057-314 Advanced PLC Software Manual* which is found on our website: [www.deepseaelectronics.com](http://www.deepseaelectronics.com)

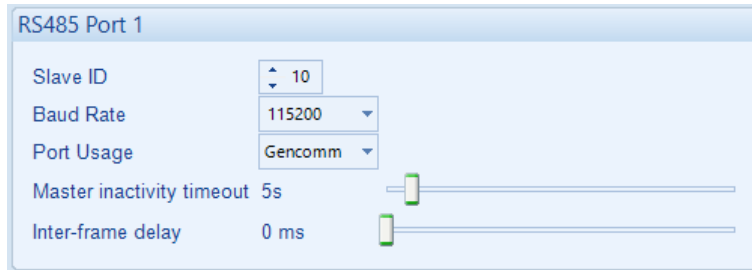

Parameter	Description
Slave ID	Select the Slave ID of the DSE module’s RS485 port. Every device on the RS485 link must have an individual Slave ID.
Baud Rate	Select the Baud Rate (speed of communication) of the DSE module’s RS485 port. Every device on the RS485 link must have the same Baud Rate. <b>1200</b> <b>2400</b> <b>4800</b> <b>9600</b> <b>14400</b> <b>19200</b> <b>28800</b> <b>38400</b> <b>57600</b> <b>115200</b>
Port Usage	<div style="border: 1px solid black; padding: 5px; margin-bottom: 5px;"> <p><b>NOTE:</b> In a system for a <i>PLC Comms</i> application, only one DSE module must be configured to act as the PLC master. For further details and instructions on using <i>the PLC Comms</i>, refer to DSE Publication: <i>057-314 Advanced PLC Software Manual</i> which is found on our website: <a href="http://www.deepseaelectronics.com">www.deepseaelectronics.com</a></p> </div> <p>Select the RS485 Port1 usage.  <b>Gencomm:</b> MODBUS RTU RS485 communication  <b>PLC Comms:</b> The RS485 Port 1 is used to read the other controllers’ registers over the RS485 link which are defined in the <i>PLC Editor</i>.</p>
Master Inactivity Timeout	Set the time delay between a MODBUS RTU request and the receipt of a response. The module monitors by default the USB port for communications. When activity is detected on the RS485 port, the module monitors the port for further data. If no data activity is detected on the port for the duration of the <i>Master Inactivity Timer</i> , it reverts to looking at the USB port. This needs to be set longer than the time between MODBUS polls from the master.
Inter-frame Delay	Set the time delay between the DSE module receiving a MODBUS RTU request and the DSE module’s response.

## 2.9.4 ETHERNET

**NOTE:** Consult the network administrator of the host network before changing these settings. Incorrect settings cause network errors in the existing local area network. These settings must only be changed by qualified network administrators.

### Dynamic Host Configuration Protocol

Dynamic Host Configuration Protocol

Obtain IP Address Automatically

Parameter	Description
Obtain IP Address Automatically	<p><input type="checkbox"/> = The Dynamic Host Configuration Protocol (DHCP) is disabled and the unit has a fixed IP address as configured in the <i>IP Address</i> section.</p> <p><input checked="" type="checkbox"/> = The Dynamic Host Configuration Protocol (DHCP) is enabled and the unit automatically attains an IP address from the network it is connected to if it has DHCP enabled.</p>

### Names

Names

Domain Name	DSE Module
Host Name	Company
Vendor Name	Deep Sea Electronics

Parameter	Description
Domain Name	The hostname of the device which is used for DHCP requests and acknowledgements. Consult the network IT manager for suitable naming
Host Name	Additional description string for DHCP
Vendor Name	Additional description string for DHCP

**IP Address**

IP Addresses				
IP address	192	168	1	100
Subnet Mask	255	255	255	0
Gateway Address	0	0	0	0
DNS Address	0	0	0	0
Preferred Connection Address	0	0	0	0

Parameter	Description
IP Address	The static IP address of the module.
Subnet Mask	The subnet mask is to determine whether the module is on the local subnet or on a remote network.
Gateway Address	IP address of the internet router that module is connected to.
DNS Address	IP address of the Domain Name Service (DNS). Usually this is the same as the module's IP address.
Preferred Connection Address	The module allows up to five MODBUS masters to connect to it. The <i>Preferred Connection Address</i> enables the unit to reserve one of the five connections for a specific IP address, such as for a remote display module to ensure it always connects.

**MODBUS**

Modbus
Modbus Port Number <input type="text" value="502"/>

Parameter	Description
MODBUS Port Number	The port number which the module serves MODBUS traffic on.

### 2.9.4.1 FIREWALL CONFIGURATION FOR INTERNET ACCESS

As modem/routers differ enormously in their configuration, it is not possible for DSE to give a complete guide to their use with the DSE module. However it is possible to give a description of the requirements in generic terms. For details of how to achieve the connection to your modem/router you are referred to the supplier of your modem/router equipment.

The DSE module makes its data available to a configurable TCP port number. You must configure your modem/router to allow inbound traffic on this port. For more information you are referred to your WAN interface device (modem/router) manufacturer.

### 2.9.4.2 INCOMING TRAFFIC (VIRTUAL SERVER)

Network Address and Port Translation (NAPT) allows a single device, such as the modem/router gateway, to act as an agent between the Internet (or "public external network") and a local (or "internal private") network. This means that only a single, unique IP address is required to represent an entire group of computers.

For our DSE module application, this means that the WAN IP address of the modem/router is the IP address we need to access the site from an external (internet) location.

When requests reach the modem/router, we want this passed to a 'virtual server' for handling, in our case this is the DSE module.

#### Example:

Virtual Servers		
Filter Name	Source Port	Destination (LAN) Address
DSE8610 MKII	1003	192.168.1.45

IP Address of the DSE controller connected to the LAN.

User provided name for the Port Forwarding rule.

Port number of the communications (must match the configuration of the DSE controller).

**Result :** Traffic arriving from the WAN (internet) on port 1003 is automatically sent to IP address 192.168.1.45 on the LAN (DSE module) for handling.

## 2.9.5 NOTIFICATIONS

The *Notifications* page is subdivided into smaller sections. Select the required section with the mouse.

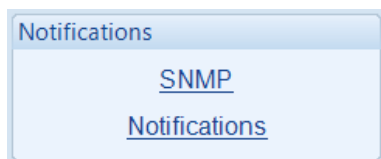

### 2.9.5.1 SNMP

 **NOTE: The SNMP V2c MIB file for the module is available to download from the DSE website: [www.deepseaelectronics.com](http://www.deepseaelectronics.com).**

The module supports SNMP v2c with GetRequest, SetRequest, GetNextRequest, GetBulkRequest and Response. The module also allows communication up to two different SNMP managers at the same time on different IP addresses.

A fixed MIB file is available for the module for use by external SNMP managers. The MIB file is a file used by the SNMP manager to give context to the information held within the module.

A screenshot of the 'SNMP Settings' configuration page. The page has a light blue header. Below the header, there is a section for 'Enable' with a checked checkbox. Below that are several input fields: 'Device Name' (DSE Module), 'Manager 1 Address' (192.168.1.99), 'Manager 2 Address' (empty), 'Manager Port' (161), 'Notification Port' (162), 'Read Community String' (public), and 'Write Community String' (private).

Parameter	Description
Enable	<input type="checkbox"/> = The SNMP function is disabled <input checked="" type="checkbox"/> = The SNMP function is enabled. The module communicates with the SNMP manager using its ethernet port.
Device Name	The name of the module which is attainable by SNMP requests using sysName OID contained within the standard RFC1213 MIB file.
Manager 1 Address	The static IP address of the first SNMP manager.
Manager 2 Address	The static IP address of the second SNMP manager.
Manager Port	The port number which the module serves SNMP GET, GET Next, Get Bulk, Get Subtree, Walk and SET messages.
Notification Port	The port number which the module sends SNMP TRAP messages via.
Read Community String	The SNMP <i>Read Community String</i> . (Factory setting <i>public</i> )
Write Community String	The SNMP <i>Write Community String</i> . (Factory setting <i>private</i> )

### 2.9.5.2 NOTIFICATIONS

The user is able to select the types of events which are sent to the SNMP managers as SNMP TRAP messages.

Notifications	
	SNMP Trap
Named Alarms	<input checked="" type="checkbox"/>
Unnamed Alarms	<input checked="" type="checkbox"/>
Mode Change	<input checked="" type="checkbox"/>
Power Up	<input type="checkbox"/>
Engine Starts	<input checked="" type="checkbox"/>
Engine Stops	<input checked="" type="checkbox"/>
Fuel Level Monitoring	<input type="checkbox"/>

Parameter	Description
Named Alarms	<input type="checkbox"/> = No SNMP TRAPs are sent when a <i>Named Alarm</i> activates. <input checked="" type="checkbox"/> = An SNMP TRAP is sent when a <i>Named Alarm</i> activates. A <i>Named Alarm</i> is a protection with a pre-set name, e.g. Generator Over Voltage.
Unnamed Alarms	<input type="checkbox"/> = No SNMP TRAPs are sent when an <i>Unnamed Alarm</i> activates. <input checked="" type="checkbox"/> = An SNMP TRAP is sent when an <i>Unnamed Alarm</i> activates. An <i>Unnamed Alarm</i> is a protection with a user configured name, e.g. a digital input configured for <i>User Configured</i> .
Mode Change	<input type="checkbox"/> = No SNMP TRAPs are sent when the module changes operating mode. <input checked="" type="checkbox"/> = An SNMP TRAP is sent to indicate the operating mode has changed and what it has changed to.
Power Up	<input type="checkbox"/> = No SNMP TRAPs are sent when the module powers up. <input checked="" type="checkbox"/> = An SNMP TRAP is sent when the module powers up.
Engine Starts	<input type="checkbox"/> = No SNMP TRAPs are sent when the engine starts. <input checked="" type="checkbox"/> = An SNMP TRAP is sent when the engine starts.
Engine Stops	<input type="checkbox"/> = No SNMP TRAPs are sent when the engine stops. <input checked="" type="checkbox"/> = An SNMP TRAP is sent when the engine stops.
Fuel Level Monitoring	<input type="checkbox"/> = No SNMP TRAPs are sent when a <i>Fuel Level Monitoring</i> event is logged within the module's event log. <input checked="" type="checkbox"/> = An SNMP TRAP is sent when a <i>Fuel Level Monitoring</i> event is logged within the module's event log.

## 2.10 SCHEDULER

The section is subdivided into smaller sections.

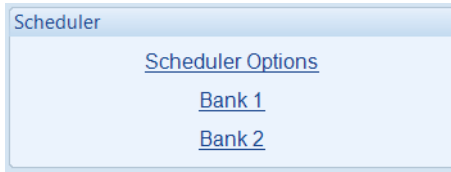

### 2.10.1 SCHEDULER OPTIONS

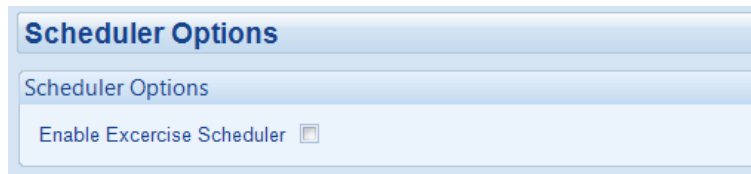

Function	Description
Enable Exercise Scheduler	<input type="checkbox"/> = The scheduler is disabled. <input checked="" type="checkbox"/> = The scheduler is enabled, Bank 1 and Bank 2 become editable.

## 2.10.2 BANK 1 / BANK 2

Each Bank of the Exercise Scheduler is used to give up to 8 scheduled runs per bank, 16 in total. This run schedule is configurable to repeat every 7 days (weekly) or every 28 days (monthly). The run is *On Load*, *Off Load* or *Auto Start Inhibit*.

Each scheduler bank configured differently either to weekly or monthly based exercises.

Function	Description
Schedule Period	Determines the repeat interval for the scheduled run. Options available are: <b>Weekly:</b> The schedule events occur every week. <b>Monthly:</b> The schedule events occur every month on the week selected.
Week	Specifies the week of the month, on which the scheduled run takes place
Day	Specifies the day of week, on which the scheduled run takes place
Run Mode	Determines the loading state mode of the generator when running on schedule  <b>Auto Start Inhibit:</b> The generator is prevented from running in <i>Auto</i> mode. <b>Off Load:</b> The module runs the generator on schedule with the load switch open <b>On Load:</b> The module runs the generator on schedule and closes the load switch
Start Time	Determines at what time of day the scheduled run starts
Duration	Determines the time duration in hours for the scheduled run
Clear	Resets the values for the Day, Start Time and Duration to defaults

## 2.11 MAINTENANCE ALARM

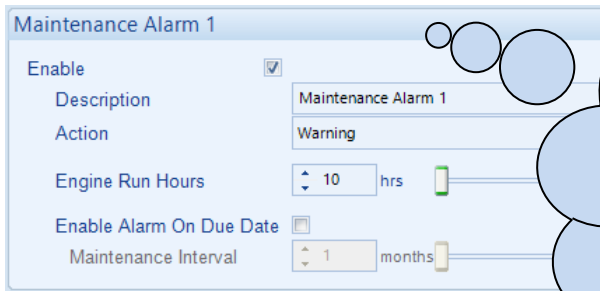

There are two ways to reset the maintenance alarm:

- 1) Activate a digital input configured to "Maintenance Reset Alarm".
- 2) Use the SCADA | Maintenance | Maintenance Alarm section of this PC Software.
- 3) Through the Front Panel Editor

### Maintenance Alarm 1 to 3

Function	Description
Enable	<input type="checkbox"/> = The maintenance alarm is disabled. <input checked="" type="checkbox"/> = The maintenance alarm is activated with the configured <i>Action</i> when the engine hours increases more than the <i>Engine Run Hours</i> or when the date increase more than the <i>Maintenance Interval</i> settings.
Description	The text that is displayed on the module's LCD when the maintenance alarm activates.
Action	<div style="border: 1px solid black; padding: 5px; margin-bottom: 5px;"> <p><b>NOTE:</b> For details of these, see the section entitled <i>Alarm Types</i> elsewhere in this document.</p> </div> Select the type of alarm required from the list: <b>Electrical Trip</b> <b>Shutdown</b> <b>Warning</b>
Engine Run Hours	The value the engine hours must increase by to trigger the maintenance alarm.
Enable Alarm on Due Date	<input type="checkbox"/> = The maintenance alarm only activates on the engine hours increasing <input checked="" type="checkbox"/> = The maintenance alarm activates on the engine hours increasing or the date increasing, whichever occurs first.
Maintenance Interval	The value the date must increase by to trigger the maintenance alarm.

## 2.12 CONFIGURABLE CAN INSTRUMENTATION

 **NOTE:** For further details and instructions on using *Configurable CAN*, refer to DSE Publication: *056-118 PLC Configurable CAN* which is found on our website: [www.deepseaelectronics.com](http://www.deepseaelectronics.com)



The *Configurable CAN Instrumentation* section is subdivided into smaller sections. Select the required section with the mouse.



### 2.12.1 RECEIVED INSTRUMENTATION (1-30)

This feature allows for up to ten custom engine CAN instrumentation items to be decoded from CAN messages on the connected ECU port.

Instrumentation Configuration				
	Enabled	On Module	Description	
1	<input checked="" type="checkbox"/>	<input checked="" type="checkbox"/>	Configurable CAN 1	Details...
2	<input checked="" type="checkbox"/>	<input checked="" type="checkbox"/>	Configurable CAN 2	Details...
3	<input checked="" type="checkbox"/>	<input checked="" type="checkbox"/>	Configurable CAN 3	Details...
4	<input checked="" type="checkbox"/>	<input checked="" type="checkbox"/>	Configurable CAN 4	Details...
5	<input checked="" type="checkbox"/>	<input checked="" type="checkbox"/>	Configurable CAN 5	Details...
6	<input checked="" type="checkbox"/>	<input checked="" type="checkbox"/>	Configurable CAN 6	Details...
7	<input checked="" type="checkbox"/>	<input checked="" type="checkbox"/>	Configurable CAN 7	Details...
8	<input checked="" type="checkbox"/>	<input checked="" type="checkbox"/>	Configurable CAN 8	Details...
9	<input checked="" type="checkbox"/>	<input checked="" type="checkbox"/>	Configurable CAN 9	Details...
10	<input checked="" type="checkbox"/>	<input checked="" type="checkbox"/>	Configurable CAN 10	Details...

Parameter	Description
Enabled	<p> <b>NOTE: The CAN instrumentation must already be available on the CAN bus. There is no request for a non-standard instrumentation.</b></p> <p><input type="checkbox"/> = The CAN instrumentation is disabled.  <input checked="" type="checkbox"/> = The CAN instrumentation is enabled. Reading depends upon the message availability on the bus.</p>
On Module	<p> <b>NOTE: The CAN instrumentation is always available on the SCADA, Data Logging, PLC as long as at least one CAN instrumentation is enabled. The CAN instrumentation is shown on the DSE module's display when the On Module is enabled.</b></p> <p><input type="checkbox"/> = The CAN instrumentation is not displayed on the DSE module.  <input checked="" type="checkbox"/> = The CAN instrumentation is displayed on the DSE module.</p>
Description	Provide a description for the CAN instrumentation. This description is only shown in the SCADA.
Details	Click on Details to set the <i>Message Decoding CAN</i> options.

### 2.12.1.1 DETAILS

#### Message Identification

Parameter	Description
Message Type	Select the required message type: <b>11 Bit:</b> message identifier for standard CAN <b>29 Bit:</b> message identifier for extended CAN
Message ID	CAN message ID
Enabled	<input type="checkbox"/> = Timeout is disabled <input checked="" type="checkbox"/> = Timeout is enabled
Timeout	It indicates how often the messages are expected to be seen on the CAN bus. If no new instrumentation is seen beyond the timeout period, the calculated instrumentation value changes to a 'bad data' sentinel value.

#### Data Structure

Parameter	Description
Offset Byte	Set the start position Byte
Offset Bit	Set the start position Bit
Length (Bits)	Data length 1-32 bits
Signed Value	<input type="checkbox"/> = Unsigned value <input checked="" type="checkbox"/> = Signed value

Parameter descriptions are continued overleaf...

**Display**

**NOTE:** If the received CAN instrument is outside the configured raw values, the module displays sentinel value.

**Display**

Decimal Places

Suffix

Smallest Raw Value  Maps To

Largest Raw Value  Maps To

Parameter	Description
Decimal Places	Display the decimal point. 0 represents 0 scaling factor, 1 represents 0.1 scaling factor, -1 represents 10 multiplier.
Suffix	Unit display (example: m <sup>3</sup> /hr)
Smallest Raw Value	The smallest data sent over the CAN bus before the transformations (decimal places).
Maps To	The output format after all transformations including decimal point shift) as to be shown on the module screen, or SCADA, in data log file, etc.
Largest Raw Value	The largest data sent over the CAN bus before the transformations (decimal places).
Maps To	The output format after all transformations including decimal point shift) as to be shown on the module screen, or SCADA, in data log file, etc.

**Test**

**Test**

Raw Value

Displayed Value 0

Parameter	Description
Test Raw Value	<p><b>NOTE:</b> The Test Raw Value is not saved in the configuration, this is only to check the displayed value.</p> <p>This is a test case to check the representation of the <i>Raw Value</i> when they are complicated. <i>Test Raw Value</i> is the value read from the CAN bus before the transformation</p>
Displayed Value	The <i>Test Raw Value</i> 's represented value as to be shown on the DSE module's screen, or in the Scada.

## 2.12.2 TRANSMITTED INSTRUMENTATION

The module allows transmitting up to ten instruments over the CANbus on the ECU port by specifying the source address (message ID) of the selected Instrument.

Parameter	Description
Enabled	<input type="checkbox"/> = The Transmit CAN instrumentation is disabled. <input checked="" type="checkbox"/> = The Transmit CAN instrumentation is enabled.
Source	Select the instrument to be created over the CAN.
Details	Click on Details to set the <i>Message Encoding</i> CAN options.

### 2.12.2.1 DETAILS

#### Message Identification

Parameter	Description
Message Type	Select the required message type to transmit: <b>11 Bit:</b> message identifier for standard CAN <b>29 Bit:</b> message identifier for extended CAN
Message ID	CAN message ID
Transmit Rate	The rate at which the <i>CAN Instrument</i> is transmitted over the CANbus.

Parameter descriptions are continued overleaf...

**Data Structure**

**Data Structure**

Offset      Byte       Bit

Length (Bits)

Signed Value

Parameter	Description
Offset Byte	Set the start position Byte
Offset Bit	Set the start position Bit
Length (Bits)	Data length 1-32 bits
Signed Value	<input type="checkbox"/> = Transmit unsigned value <input checked="" type="checkbox"/> = Transmit signed value

**Mapping**

**Mapping**

Smallest Source Value       Maps To

Largest Source Value       Maps To

Parameter	Description
Smallest Source Value	The smallest instrument value before being sent over the CAN bus.
Maps To	The transmitted format for the <i>Smallest Source Value</i> .
Largest Source Value	The largest instrument value before being sent over the CAN bus.
Maps To	The transmitted format for the <i>Largest Source Value</i> .

**Test**

**Test**

Source Value

Mapped Value 0

Parameter	Description
Source Value	<div style="border: 3px double black; padding: 5px;"> <p><b>▲ NOTE: The Source Value is not transmitted over the CANbus, this is only to check the encoded value.</b></p> </div> <p>This is a test case to check the representation of the <i>Source Value</i> when they are complicated. <i>Source Value</i> is the instrument value before being encoded.</p>
Mapped Value	The <i>Mapped Value</i> represents the transmitted <i>Source value</i> .

### 2.12.3 EXPORT / IMPORT CONFIGURABLE CAN

This feature is used to import the *Configurable CAN Instrumentation* settings into another DSE module.

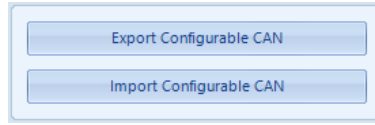

Parameter	Description
Export	This allows the configuration settings of all Configurable CAN Instrumentation (Received & Transmitted) into one XML file.
Import	This allows to import an existing configuration settings of all Configurable CAN Instrumentation saved in XML format.

## 2.13 ALTERNATIVE CONFIGURATIONS

An Alternative Configurations are provided to allow the system designer to cater for different AC requirements utilising the same generator system. Typically this feature is used by Rental Set Manufacturers where the set is capable of being operated at (for instance) 120 V 50 Hz and 240V 50 Hz using a selector switch.

The Alternative Configuration is selected using either:

- Configuration Suite Software (Selection for 'Default Configuration')
- Module Front Panel Editor
- Via external signal to the module input configured to "Alternative Configuration" select.

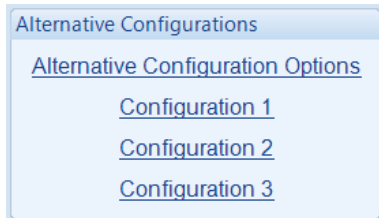

### 2.13.1 ALTERNATIVE CONFIGURATION OPTIONS

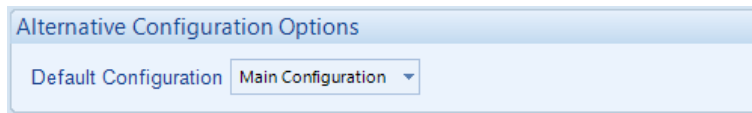

Parameter	Description
Default Configuration	Select the 'default' configuration that is used when there is no instruction to use an 'alternative configuration'.

## 2.13.2 ALTERNATIVE CONFIGURATION 1 TO 3

The Alternative Configurations Editor allows for editing of the parameters that are to be changed when an Alternative Configuration is selected.

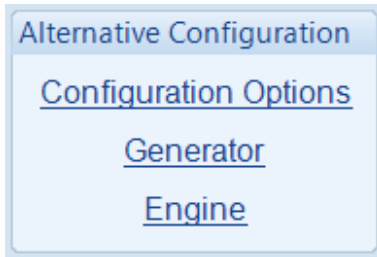

### 2.13.2.1 CONFIGURATION OPTIONS

#### Enable Alternative Configuration

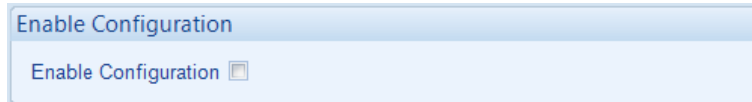

Parameter	Description
Enable Configuration	<input type="checkbox"/> = <i>Alternative Configuration</i> is disabled. <input checked="" type="checkbox"/> = <i>Alternative Configuration</i> is enabled. The configuration is enabled by changing the <i>Default Configuration</i> , activating a digital input or through the module's <i>Front Panel Editor</i> .

### 2.13.2.2 GENERATOR / ENGINE

Alternative configuration options contain a subset of the main configuration. The adjustable parameters are not discussed here as they are identical to the main configuration options:

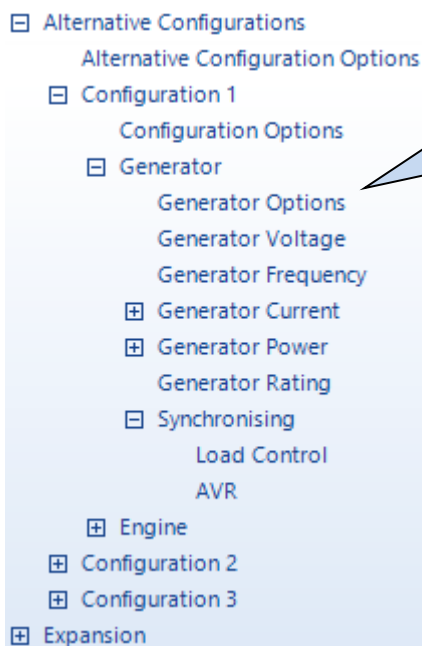

Configuration menus for the *Alternative Configuration*. For information about the configuration items within this section, refer to their description in the 'main' configuration.

## 2.14 EXPANSION

The *Expansion* page is subdivided into smaller sections. Select the required section with the mouse.

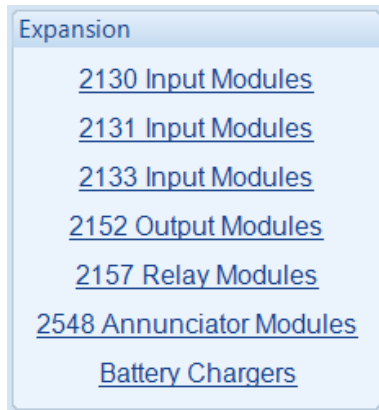

See overleaf for description of the different expansion modules.

## 2.14.1 DSE2130 INPUT MODULES

Select the DSENet ID of the input expansion to be configured. The ID of the expansion module is set by rotary decimal switch accessible under the removable cover of the device.

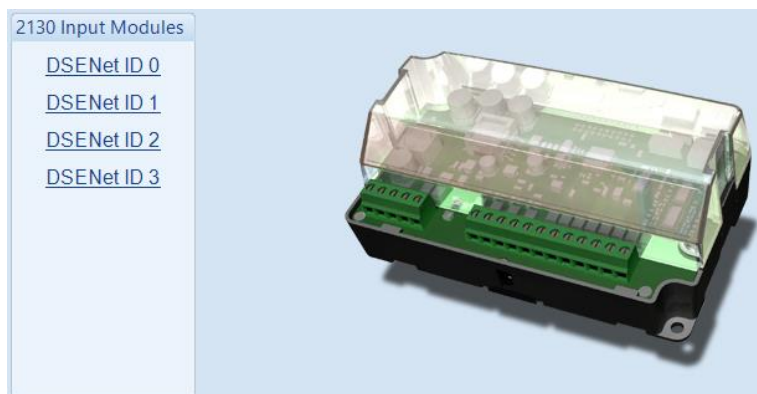

The following options are then shown:

### 2130 Expansion Enable

2130 Expansion Enable

Expansion Enabled

Link Lost Alarm Action Shutdown ▾

Parameter	Description
Expansion Enabled	<p><input type="checkbox"/> = The expansion module with the selected ID is not enabled.</p> <p><input checked="" type="checkbox"/> = The expansion module with the selected ID is enabled. If the expansion module is not connected / detected by the module, the module generates an <i>Exp. Unit Failure</i> alarm with the configured <i>Link Lost Alarm Action</i> severity.</p>

### 2130 Expansion Inputs

The *Expansion Unit* page is then subdivided into smaller sections. Select the required section with the mouse.

2130 Expansion Inputs

[Analogue Input Configuration](#)  
[Analogue Inputs](#)  
[Digital Inputs](#)

### 2.14.1.1 ANALOGUE INPUT CONFIGURATION

#### Input Configuration

Parameter	Description
Analogue Input E to H	Select what the analogue input is to be used for: <b>Not Used:</b> The analogue input is disabled <b>Digital Input:</b> Configured on the 2130/Digital Inputs pages <b>Flexible Analogue:</b> Configured on the 2130/Analogue Inputs pages

### 2.14.1.2 ANALOGUE INPUTS

 **NOTE:** An analogue input is only configurable as a flexible sensor if it has been configured as Flexible Analogue, refer to section entitled *Analogue Input Configuration* elsewhere in this document for further details.

#### Sensor Description

Parameter	Description
Sensor Name	Enter the <i>Sensor Name</i> , this text is shown on the module display when viewing the instrument.

#### Input Type

Parameter	Description
Input Type	Select the sensor type and curve from a pre-defined list or create a user-defined curve.  Available sensor types: <b>Resistive:</b> for sensors with maximum range of 0 $\Omega$ to 480 $\Omega$  Available parameters to be measured: <b>Pressure:</b> The input is configured as a pressure sensor <b>Percentage:</b> The input is configured as a percentage sensor <b>Temperature:</b> The input is configured as a temperature sensor

Parameter descriptions are continued overleaf...

**Sensor Alarms**

Parameter	Description
Alarm Arming	<p><b>NOTE:</b> For details of these, see the section entitled <i>Alarm Arming</i> elsewhere in this document.</p> <p>Select when the alarm generated by the analogue input becomes active:  <b>Always</b>  <b>From Safety On</b>  <b>From Starting</b></p>
Low Alarm Enable	<p><input type="checkbox"/> = The Alarm is disabled.  <input checked="" type="checkbox"/> = The <i>Low Alarm</i> activates when the measured quantity drops below the <i>Low Alarm</i> setting.</p>
Low Alarm Action	<p><b>NOTE:</b> For details of these, see the section entitled <i>Alarm Types</i> elsewhere in this document.</p> <p>Select the type of alarm required from the list:  <b>Electrical Trip</b>  <b>Shutdown</b></p>
Low Pre-Alarm Enable	<p><input type="checkbox"/> = The Pre-Alarm is disabled.  <input checked="" type="checkbox"/> = The <i>Low Pre-Alarm</i> is active when the measured quantity drops below the <i>Low Pre-Alarm Trip</i> setting. The <i>Low Pre-Alarm</i> is automatically reset when the measured quantity rises above the configured <i>Low Pre-Alarm Return</i> level.</p>
Low Alarm String	<p>The text that is displayed on the module's LCD when the <i>Low Alarm</i> or <i>Low Pre-Alarm</i> activates.</p>

Parameter descriptions are continued overleaf...

Editing the Configuration

Parameter	Description
High Pre-Alarm Enable	<input type="checkbox"/> = The Pre-Alarm is disabled. <input checked="" type="checkbox"/> = The <i>High Pre-Alarm</i> is active when the measured quantity rises above the <i>High Pre-Alarm Trip</i> setting. The <i>High Pre-Alarm</i> is automatically reset when the measured quantity falls below the configured <i>High Pre-Alarm Return</i> level.
High Alarm Enable	<input type="checkbox"/> = The Alarm is disabled. <input checked="" type="checkbox"/> = The <i>High Alarm</i> is active when the measured quantity rises above the <i>High Alarm</i> setting.
High Alarm Action	<div style="border: 3px double black; padding: 5px;"> <p> <b>NOTE: For details of these, see the section entitled <i>Alarm Types</i> elsewhere in this document.</b></p> </div> <p>Select the type of alarm required from the list:  <b><i>Electrical Trip</i></b>  <b><i>Shutdown</i></b></p>
High Alarm String	The text that is displayed on the module's LCD when the <i>High Alarm</i> or <i>High Pre-Alarm</i> activates.

### 2.14.1.3 DIGITAL INPUTS

The *Digital Inputs* section is subdivided into smaller sections. Select the required section with the mouse.

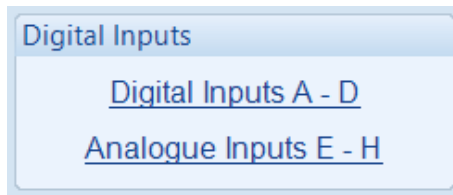

2.14.1.3.1 DIGITAL INPUTS

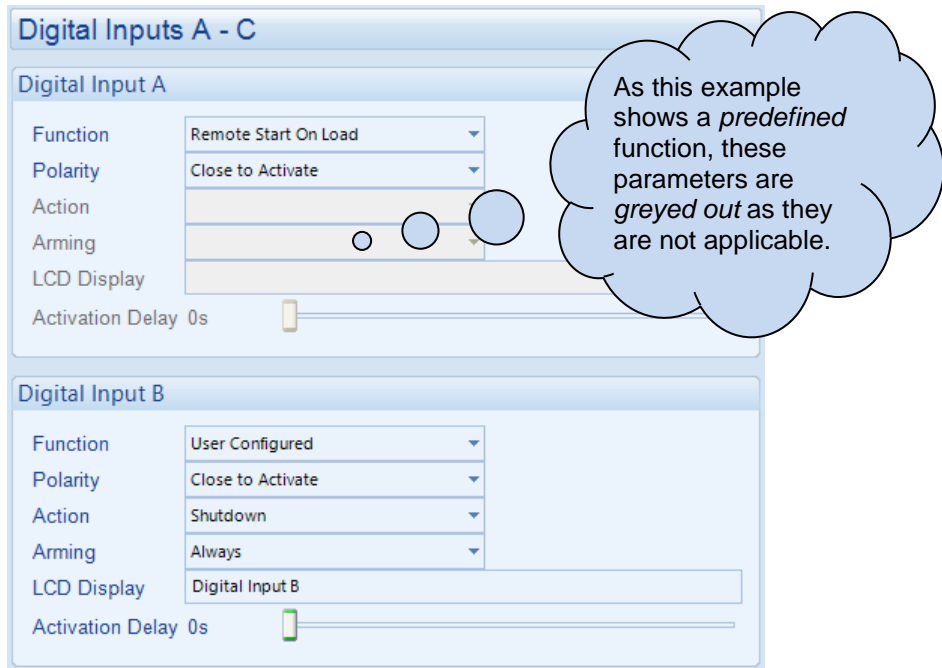

Parameter	Description
Function	Select the input function to activate when the relevant terminal is energised. See section entitled <i>Input Functions</i> for details of all available functions
Polarity	Select the digital input polarity: <b>Close to Activate:</b> the input function is activated when the relevant terminal is connected. <b>Open to Activate:</b> the input function is activated when the relevant terminal is disconnected.
Action	<div style="border: 1px solid black; padding: 5px;"> <p><b>⚠ NOTE: For details of these, see the section entitled <i>Alarm Types</i> elsewhere in this document.</b></p> </div> <p>Select the type of alarm required from the list:  <b>Electrical Trip Indication</b>  <b>Shutdown</b>  <b>Warning</b></p>
Arming	<div style="border: 1px solid black; padding: 5px;"> <p><b>⚠ NOTE: For details of these, see the section entitled <i>Alarm Arming</i> elsewhere in this document.</b></p> </div> <p>Select when the input becomes active:  <b>Active from Mains Parallel</b>  <b>Always</b>  <b>From Safety On</b>  <b>From Starting</b>  <b>Never</b></p>
LCD Display	The text that is displayed on the module's LCD when the input activates and generates an alarm.
Activation Delay	This is used to give a delay on acceptance of the input. Useful for liquid level switches or to mask short term operations of the external switch device.

2.14.1.3.2 ANALOGUE INPUTS

**NOTE:** An analogue input is only configurable as a digital input if it has been configured as Digital Input, refer to section entitled *Analogue Input Configuration* elsewhere in this document for further details.

### Analogue Inputs E - H

**Analogue Input E (Digital)**

Function	User Configured
Polarity	Close to Activate
Action	Warning
Arming	Always
LCD Display	2130 ID0 Analogue E (Digital)
Activation Delay 0s	<input type="range"/>

**Analogue Input F (Digital)**

The Analogue Input is not configured as a Digital Input  
To reconfigure, use the 'Analogue Input Configuration' page

Parameter	Description
Function	Select the input function to activate when the relevant terminal is energised. See section entitled <i>Input Functions</i> for details of all available functions
Polarity	Select the digital input polarity: <b>Close to Activate:</b> the input function is activated when the relevant terminal is connected. <b>Open to Activate:</b> the input function is activated when the relevant terminal is disconnected.
Action	<div style="border: 1px solid black; padding: 5px; margin-bottom: 5px;"> <p><b>NOTE:</b> For details of these, see the section entitled <i>Alarm Types</i> elsewhere in this document.</p> </div> <p>Select the type of alarm required from the list: <b>Electrical Trip</b> <b>Indication</b> <b>Shutdown</b> <b>Warning</b></p>
Arming	<div style="border: 1px solid black; padding: 5px; margin-bottom: 5px;"> <p><b>NOTE:</b> For details of these, see the section entitled <i>Alarm Arming</i> elsewhere in this document.</p> </div> <p>Select when the input becomes active: <b>Active from Mains Parallel</b> <b>Always</b> <b>From Safety On</b> <b>From Starting</b> <b>Never</b></p>
LCD Display	The text that is displayed on the module's LCD when the input activates and generates an alarm.
Activation Delay	This is used to give a delay on acceptance of the input. Useful for liquid level switches or to mask short term operations of the external switch device.

## 2.14.2 DSE2131 INPUT MODULES

Select the DSENet ID of the input expansion to be configured. The ID of the expansion module is set by rotary decimal switch accessible under the removable cover of the device.



The following options are then shown:

### 2131 Expansion Enable

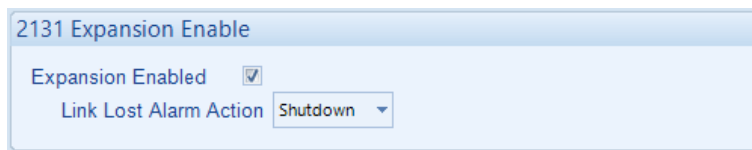

Parameter	Description
Expansion Enabled	<input type="checkbox"/> = The expansion module with the selected ID is not enabled. <input checked="" type="checkbox"/> = The expansion module with the selected ID is enabled. If the expansion module is not connected / detected by the module, the module generates an <i>Exp. Unit Failure</i> alarm with the configured <i>Link Lost Alarm Action</i> severity.

### 2131 Expansion Inputs

The *Expansion Unit* page is then subdivided into smaller sections. Select the required section with the mouse.

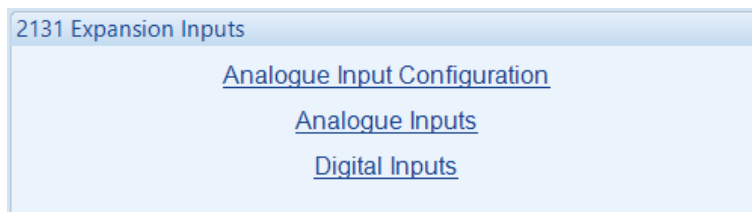

### 2.14.2.1 ANALOGUE INPUT CONFIGURATION

Input Configuration	
Analogue Input A	Flexible Analogue ▾
Analogue Input B	Flexible Analogue ▾
Analogue Input C	Not Used ▾
Analogue Input D	Flexible Analogue ▾
Analogue Input E	Digital Input ▾
Analogue Input F	Digital Input ▾
Analogue Input G	Digital Input ▾
Analogue Input H	Flexible Analogue ▾
Analogue Input I	Digital Input ▾
Analogue Input J	Not Used ▾

#### Input Configuration

Parameter	Description
Analogue Input A to J	Select what the analogue input is to be used for: <b>Not Used:</b> The analogue input is disabled <b>Digital Input:</b> Configured on the 2131/Digital Inputs pages <b>Flexible Analogue:</b> Configured on the 2131/Analogue Inputs pages

### 2.14.2.2 ANALOGUE INPUTS

**NOTE:** An analogue input is only configurable as a flexible sensor if it has been configured as Flexible Analogue, refer to section entitled *Analogue Input Configuration* elsewhere in this document for further details.

#### Sensor Description

Sensor Description

Sensor Name

Parameter	Description
Sensor Name	Enter the <i>Sensor Name</i> , this text is shown on the module display when viewing the instrument.

#### Input Type

Input Type

VDO Ohm range (10-180)

Parameter	Description
Input Type	<p>Select the sensor type and curve from a pre-defined list or create a user-defined curve.</p> <p>Available sensor types:</p> <p><b>Current:</b> for sensors with maximum range of 0 mA to 20 mA</p> <p><b>Resistive:</b> for sensors with maximum range of 0 Ω to 1920 Ω</p> <p><b>Voltage:</b> for sensors with maximum range of 0 V to 10 V</p> <p>Available parameters to be measured:</p> <p><b>Pressure:</b> The input is configured as a pressure sensor</p> <p><b>Percentage:</b> The input is configured as a percentage sensor</p> <p><b>Temperature:</b> The input is configured as a temperature sensor</p>

Parameter descriptions are continued overleaf...

**Sensor Alarms**

Parameter	Description
Alarm Arming	<p><b>NOTE:</b> For details of these, see the section entitled <i>Alarm Arming</i> elsewhere in this document.</p> <p>Select when the alarm generated by the analogue input becomes active:  <b>Always</b>  <b>From Safety On</b>  <b>From Starting</b></p>
Low Alarm Enable	<p><input type="checkbox"/> = The Alarm is disabled.  <input checked="" type="checkbox"/> = The <i>Low Alarm</i> activates when the measured quantity drops below the <i>Low Alarm</i> setting.</p>
Low Alarm Action	<p><b>NOTE:</b> For details of these, see the section entitled <i>Alarm Types</i> elsewhere in this document.</p> <p>Select the type of alarm required from the list:  <b>Electrical Trip</b>  <b>Shutdown</b></p>
Low Pre-Alarm Enable	<p><input type="checkbox"/> = The Pre-Alarm is disabled.  <input checked="" type="checkbox"/> = The <i>Low Pre-Alarm</i> is active when the measured quantity drops below the <i>Low Pre-Alarm Trip</i> setting. The <i>Low Pre-Alarm</i> is automatically reset when the measured quantity rises above the configured <i>Low Pre-Alarm Return</i> level.</p>
Low Alarm String	<p>The text that is displayed on the module's LCD when the <i>Low Alarm</i> or <i>Low Pre-Alarm</i> activates.</p>

Parameter descriptions are continued overleaf...

Editing the Configuration

Parameter	Description
High Pre-Alarm Enable	<input type="checkbox"/> = The Pre-Alarm is disabled. <input checked="" type="checkbox"/> = The <i>High Pre-Alarm</i> is active when the measured quantity rises above the <i>High Pre-Alarm Trip</i> setting. The <i>High Pre-Alarm</i> is automatically reset when the measured quantity falls below the configured <i>High Pre-Alarm Return</i> level.
High Alarm Enable	<input type="checkbox"/> = The Alarm is disabled. <input checked="" type="checkbox"/> = The <i>High Alarm</i> is active when the measured quantity rises above the <i>High Alarm</i> setting.
High Alarm Action	<div style="border: 1px solid black; padding: 5px;"> <p> <b>NOTE: For details of these, see the section entitled <i>Alarm Types</i> elsewhere in this document.</b></p> </div> <p>Select the type of alarm required from the list:  <b><i>Electrical Trip</i></b>  <b><i>Shutdown</i></b></p>
High Alarm String	The text that is displayed on the module's LCD when the <i>High Alarm</i> or <i>High Pre-Alarm</i> activates.

### 2.14.2.3 DIGITAL INPUTS

**NOTE:** An analogue input is only configurable as a digital input if it has been configured as Digital Input, refer to section entitled *Analogue Input Configuration* elsewhere in this document for further details.

**Analogue Inputs A - C**

**Analogue Input A (Digital)**

Function	Alarm Mute
Polarity	Close to Activate
Action	
Arming	
LCD Display	2131 ID0 Flexible Sensor A
Activation Delay	0s

**Analogue Input B (Digital)**



Function	User Configured
Polarity	Close to Activate
Action	Warning
Arming	Always
LCD Display	2131 ID0 Flexible Sensor B
Activation Delay	0s

**Analogue Input C (Digital)**

The Analogue Input is not configured as a Digital Input  
To reconfigure, use the 'Analogue Input Configuration' page

As this example shows a *predefined* function, these parameters are *greyed out* as they are not applicable.

Parameter descriptions are overleaf...

Parameter	Description
Function	Select the input function to activate when the relevant terminal is energised. See section entitled <i>Input Functions</i> for details of all available functions
Polarity	Select the digital input polarity: <b>Close to Activate:</b> The input function is activated when the relevant terminal is connected. <b>Open to Activate:</b> The input function is activated when the relevant terminal is disconnected.
Action	<div style="border: 1px solid black; padding: 5px;">  <b>NOTE: For details of these, see the section entitled <i>Alarm Types</i> elsewhere in this document.</b> </div> Select the type of alarm required from the list: <b>Electrical Trip Indication</b> <b>Shutdown</b> <b>Warning</b>
Arming	<div style="border: 1px solid black; padding: 5px;">  <b>NOTE: For details of these, see the section entitled <i>Alarm Arming</i> elsewhere in this document.</b> </div> Select when the input becomes active: <b>Active from Mains Parallel</b> <b>Always</b> <b>From Safety On</b> <b>From Starting</b> <b>Never</b>
LCD Display	The text that is displayed on the module's LCD when the input activates and generates an alarm.
Activation Delay	This is used to give a delay on acceptance of the input. Useful for liquid level switches or to mask short term operations of the external switch device.

### 2.14.3 DSE2133 INPUT MODULES

Select the DSENet ID of the input expansion to be configured. The ID of the expansion module is set by rotary decimal switch accessible under the removable cover of the device.

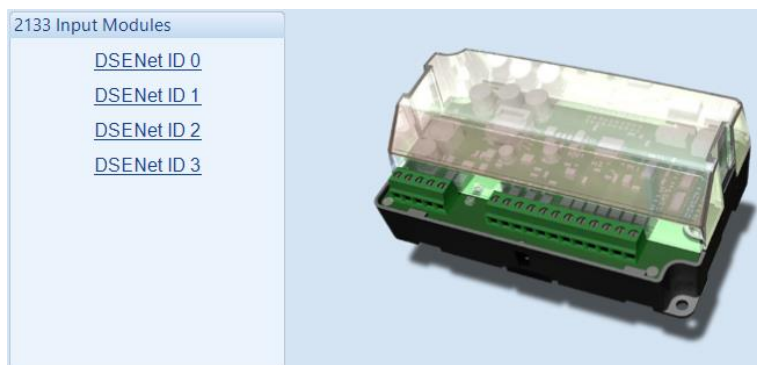

The following options are then shown:

#### 2133 Expansion Enable

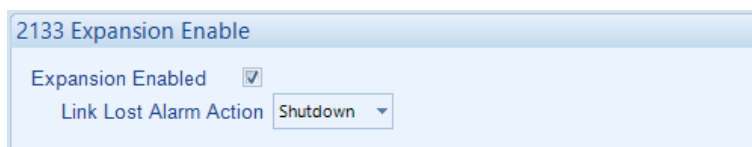

Parameter	Description
Expansion Enabled	<input type="checkbox"/> = The expansion module with the selected ID is not enabled. <input checked="" type="checkbox"/> = The expansion module with the selected ID is enabled. If the expansion module is not connected / detected by the module, the module generates an <i>Exp. Unit Failure</i> alarm with the configured <i>Link Lost Alarm Action</i> severity.

#### 2133 Expansion Inputs

The *Expansion Unit* page is then subdivided into smaller sections. Select the required section with the mouse.

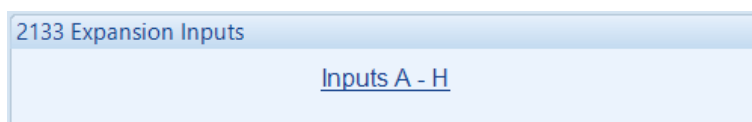

### 2.14.3.1 ANALOGUE INPUTS

**NOTE:** An analogue input is only configurable as a flexible sensor if it has been configured as Flexible Analogue, refer to section entitled *Analogue Input Configuration* elsewhere in this document for further details.

#### Sensor Description

Sensor Description

Sensor Name

Parameter	Description
Sensor Name	Enter the <i>Sensor Name</i> , this text is shown on the module display when viewing the instrument.

#### Input Type

Input Type

Parameter	Description
Input Type	Select the sensor type from the pre-defined list: <b>2 Wire PT100</b> <b>3 Wire PT100</b> <i>Type J (Thermocouple)</i> <i>Type K (Thermocouple)</i>

Parameter descriptions are continued overleaf...

**Sensor Alarms**

Parameter	Description
Alarm Arming	<p><b>NOTE:</b> For details of these, see the section entitled <i>Alarm Arming</i> elsewhere in this document.</p> <p>Select when the alarm generated by the analogue input becomes active:  <b>Always</b>  <b>From Safety On</b>  <b>From Starting</b></p>
Low Alarm Enable	<p><input type="checkbox"/> = The Alarm is disabled.  <input checked="" type="checkbox"/> = The <i>Low Alarm</i> activates when the measured quantity drops below the <i>Low Alarm</i> setting.</p>
Low Alarm Action	<p><b>NOTE:</b> For details of these, see the section entitled <i>Alarm Types</i> elsewhere in this document.</p> <p>Select the type of alarm required from the list:  <b>Electrical Trip</b>  <b>Shutdown</b></p>
Low Pre-Alarm Enable	<p><input type="checkbox"/> = The Pre-Alarm is disabled.  <input checked="" type="checkbox"/> = The <i>Low Pre-Alarm</i> is active when the measured quantity drops below the <i>Low Pre-Alarm Trip</i> setting. The <i>Low Pre-Alarm</i> is automatically reset when the measured quantity rises above the configured <i>Low Pre-Alarm Return</i> level.</p>
Low Alarm String	The text that is displayed on the module's LCD when the <i>Low Alarm</i> or <i>Low Pre-Alarm</i> activates.

Parameter descriptions are continued overleaf...

Editing the Configuration

Parameter	Description
High Pre-Alarm Enable	<input type="checkbox"/> = The Pre-Alarm is disabled. <input checked="" type="checkbox"/> = The <i>High Pre-Alarm</i> is active when the measured quantity rises above the <i>High Pre-Alarm Trip</i> setting. The <i>High Pre-Alarm</i> is automatically reset when the measured quantity falls below the configured <i>High Pre-Alarm Return</i> level.
High Alarm Enable	<input type="checkbox"/> = The Alarm is disabled. <input checked="" type="checkbox"/> = The <i>High Alarm</i> is active when the measured quantity rises above the <i>High Alarm</i> setting.
High Alarm Action	<div style="border: 1px solid black; padding: 5px;"> <p> <b>NOTE: For details of these, see the section entitled <i>Alarm Types</i> elsewhere in this document.</b></p> </div> <p>Select the type of alarm required from the list:  <b><i>Electrical Trip</i></b>  <b><i>Shutdown</i></b></p>
High Alarm String	The text that is displayed on the module's LCD when the <i>High Alarm</i> or <i>High Pre-Alarm</i> activates.

## 2.14.4 DSE2152 OUTPUT MODULES

Select the DSENet ID of the output expansion to be configured. The ID of the expansion input module is set by rotary decimal switch accessible under the removable cover of the device.



The following options are then shown:

### 2152 Expansion Enable

**2152 Expansion Enable**

Expansion Enabled

Link Lost Alarm Action Shutdown ▾

Parameter	Description
Expansion Enabled	<input type="checkbox"/> = The expansion module with the selected ID is not enabled. <input checked="" type="checkbox"/> = The expansion module with the selected ID is enabled. If the expansion module is not connected / detected by the module, the module generates an <i>Exp. Unit Failure</i> alarm with the configured <i>Link Lost Alarm Action</i> severity.

### 2152 Expansion Outputs

The *Expansion Unit* page is then subdivided into smaller sections. Select the required section with the mouse.

**2152 Expansion Outputs**

[Outputs A - F](#)

### 2.14.4.1 ANALOGUE OUTPUTS

#### Analogue Output A

##### Output Configuration

Output Name

##### Output Type

Source <input type="text" value="Generator Power Total"/>	Curve <input type="text" value="0kW to 100kW = 0V to 10V"/>	<input type="button" value="Edit..."/>
--------------------------------------------------------------	----------------------------------------------------------------	----------------------------------------

#### Output Configuration

##### Output Configuration

Output Name

Parameter	Description
Output Name	Enter the <i>Output Name</i> , this text is shown on in the SCADA section when viewing the output.

#### Output Type

##### Output Type

Source <input type="text" value="Generator Power Total"/>	Curve <input type="text" value="0kW to 100kW = 0V to 10V"/>	<input type="button" value="Edit..."/>
--------------------------------------------------------------	----------------------------------------------------------------	----------------------------------------

Click to edit the 'output curve'. See section entitled *Editing the Output Curve*.

Parameter	Description
Source	Select the parameter that is to be mapped to the analogue output.
Curve	Select the output type and curve from a pre-defined list or create a user-defined curve <b>Current:</b> for sensors with maximum range of 0 mA to 20 mA <b>Voltage:</b> for sensors with maximum range of 0 V to 10 V

### 2.14.4.2 CREATING / EDITING THE OUTPUT CURVE

While the *DSE Configuration Suite* holds specifications for the most used output ranges, occasionally it is required that the expansion module's output be connected to a none standard device. To aid this process, a curve editor is provided.

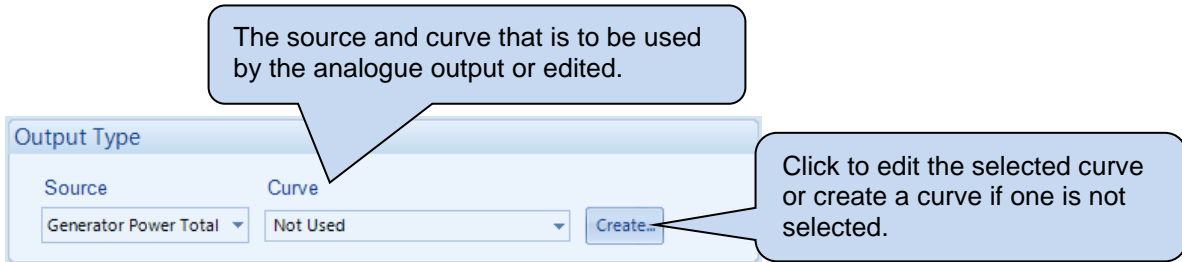

When creating a new sensor curve the measurement quantity and measured parameter are required.

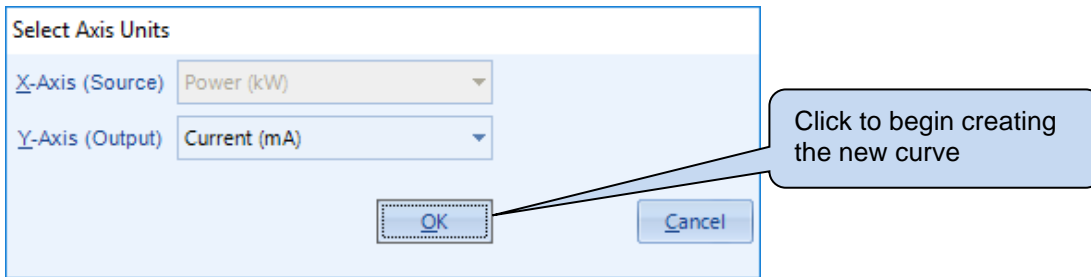

Parameter	Description
Y-Axis (Source)	The parameter measured by the DSE module that is to be mapped to the output.
X-Axis (Output)	Select the electrical quantity that the sensor outputs. <b>Current (mA):</b> For an output current within a range 0 mA to 20 mA <b>Voltage (Volt):</b> For an output voltage within a range of 0 V to 10 V

Curve creation / editor descriptions are continued overleaf...

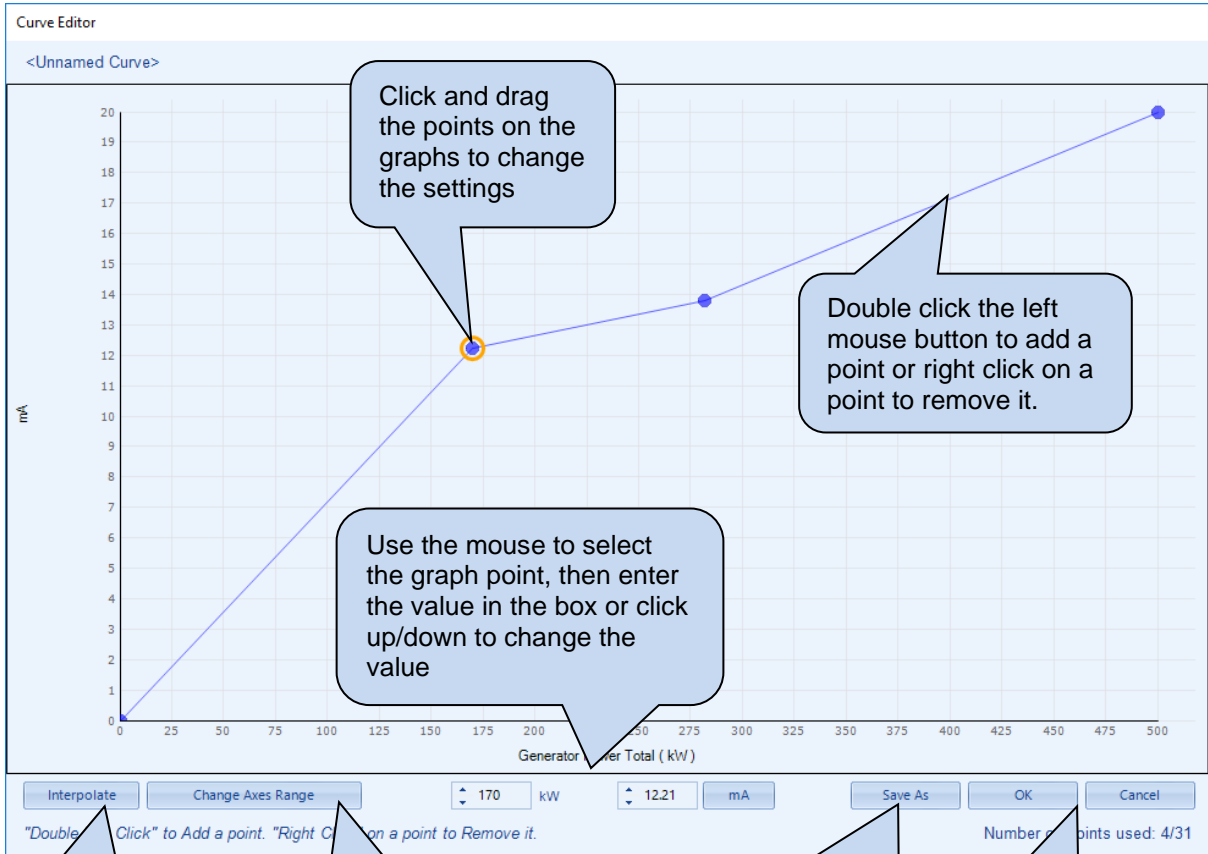

Click *Interpolate* then select two points as prompted to draw a straight line between

Click to change the range of the X and Y Axes of the graph and the level of open circuit

Click SAVE AS, a prompt to name the curve...

New Curve Name

Enter a name for the new curve

OK Cancel

Click OK to save the curve.

**Any saved curves become selectable in the *Output Type* selection list.**

Click OK to accept the changes or CANCEL to ignore and lose the

**Hint:** Deleting, renaming or editing custom curves that have been added is performed in the main menu, select *Tools | Curve Manager*.

### 2.14.5 DSE2157 RELAY MODULES

Select the DSENet ID of the output expansion to be configured. The ID of the expansion module is set by rotary decimal switch accessible under the removable cover of the device.

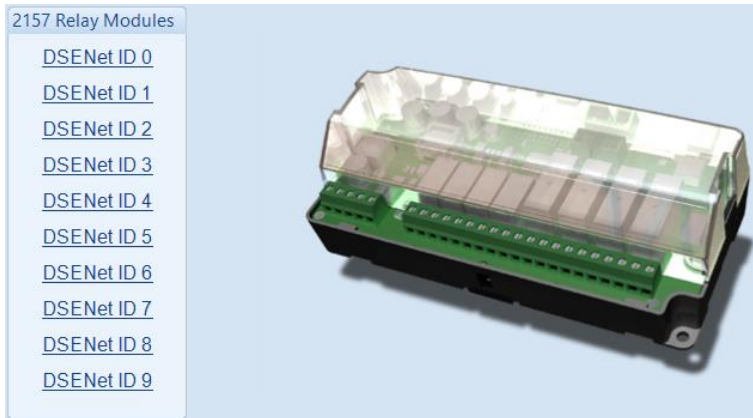

The following options are then shown:

#### 2152 Expansion Enable

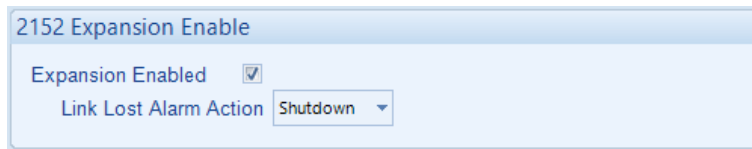

Parameter	Description
Expansion Enabled	<input type="checkbox"/> = The expansion module with the selected ID is not enabled. <input checked="" type="checkbox"/> = The expansion module with the selected ID is enabled. If the expansion module is not connected / detected by the module, the module generates an <i>Exp. Unit Failure</i> alarm with the configured <i>Link Lost Alarm Action</i> severity.

#### Relay Outputs (Normally Open / Changeover)

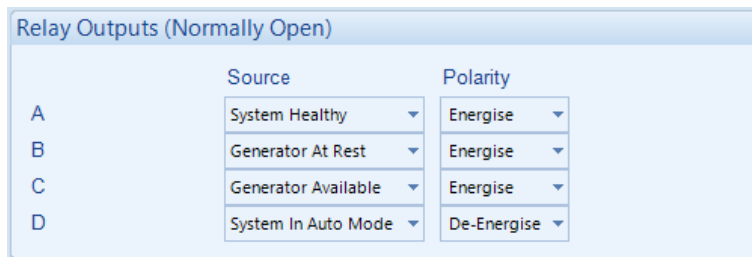

Parameter	Description
Source	Select the output source to control the state of the output See section entitled <i>Output Sources</i> for details of all available functions
Polarity	Select the digital input polarity: <b>Energise:</b> When the output source is true, the output activates. <b>De-Energise:</b> When the output source is true, the output deactivates.

## 2.14.6 DSE2548 ANNUCIATOR MODULES

Select the DSENet ID of the LED expansion to be configured. The ID of the expansion input module is set by rotary decimal switch accessible on the rear of the device.



The following options are then shown:

### 2548 Expansion Enable

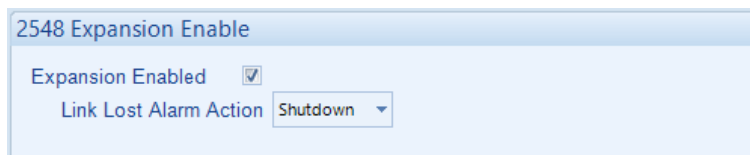

Parameter	Description
Expansion Enabled	<input type="checkbox"/> = The expansion module with the selected ID is not enabled. <input checked="" type="checkbox"/> = The expansion module with the selected ID is enabled. If the expansion module is not connected / detected by the module, the module generates an <i>Exp. Unit Failure</i> alarm with the configured <i>Link Lost Alarm Action</i> severity.

### Sounder Configuration

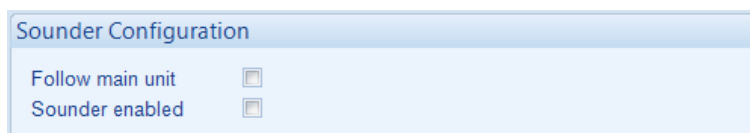

Parameter	Description
Follow Main Unit	<input type="checkbox"/> = If the <i>mute / lamp test</i> button is pressed, other DSE2548 modules and the host module does not respond to this. <input checked="" type="checkbox"/> = If the <i>mute / lamp test</i> button is pressed, other DSE2548 modules configured to <i>Follow main unit</i> and the host module also lamp test / mute their alarm and vice-versa.
Sounder Enabled	<input type="checkbox"/> = The DSE2548 internal sounder does not annunciate on a fault condition becoming active. <input checked="" type="checkbox"/> = The DSE2548 internal sounder annunciates on a fault condition becoming active.

Parameter descriptions are continued overleaf...

**LED Indicators**

LED	Source	Polarity
A	System In Auto Mode	Unlit
B	Generator Load Inhibited	Lit
C	Combined Remote Start Request	Lit
D	Common Alarm	Lit
E	Not Used	Lit
F	Not Used	Lit
G	Not Used	Lit
H	Not Used	Lit

Annunciator Insert Card

Parameter	Description
Source	Select the output source to control the state of the output See section entitled <i>Output Sources</i> for details of all available functions
Polarity	Select the digital input polarity: <b>Energise:</b> When the output source is true, the output activates. <b>De-Energise:</b> When the output source is true, the output deactivates.
Annunciator Insert Card	Allows the user to create and print the custom text insert cards for the LEDs.

## 2.14.7 BATTERY CHARGERS

Select the DSENet ID of the battery charger to be configured. The ID of the expansion module is set by configuration of the device.



The following options are then shown:

### DSENet ID

DSENet ID 0

Enable

Link Lost Alarm Action

Modbus Slave ID

Display Instrumentation

Charger Name

Parameter	Description
Enable	<input type="checkbox"/> = The battery charger with the selected ID is not enabled. <input checked="" type="checkbox"/> = The battery charger with the selected ID is enabled. If the expansion module is not connected / detected by the module, the module generates an <i>Exp. Unit Failure</i> alarm with the configured <i>Link Lost Alarm Action</i> severity.
Modbus Slave ID	The Slave ID used to address the battery charger via the host module's RS485 when using the host module as a MODBUS RTU pass through.
Display Instrumentation	<input type="checkbox"/> = The battery chargers' information is not shown on the host module's display. <input checked="" type="checkbox"/> = The battery charger information is shown on the host module's display.
Charger Name	Enter the <i>Charger Name</i> , this text is shown on the module display when viewing the battery charger instrumentation

**Charger Shutdown Alarms**

**Charger Shutdown Alarms**

Enable

Module Action Warning

Alarm String Charger ID0 Common Shutdown

Parameter	Description
Enable	<input type="checkbox"/> = The DSE module does not display any shutdown alarms from the battery charger. <input checked="" type="checkbox"/> = The DSE module displays shutdown alarms from the battery charger with the configured action.
Alarm String	The text that is displayed on the module's LCD when the DSE module detects a shutdown fault from the battery charger.

**Charger Warning Alarms**

**Charger Warning Alarms**

Enable

Module Action Warning

Alarm String Charger ID0 Common Warning

Parameter	Description
Enable	<input type="checkbox"/> = The DSE module does not display any warning alarms from the battery charger. <input checked="" type="checkbox"/> = The DSE module displays warnings alarms from the battery charger with the configured action.
Alarm String	The text that is displayed on the module's LCD when the DSE module detects a warning fault from the battery charger.

## 2.15 ADVANCED

The *Advanced* page is subdivided into smaller sections. Select the required section with the mouse.

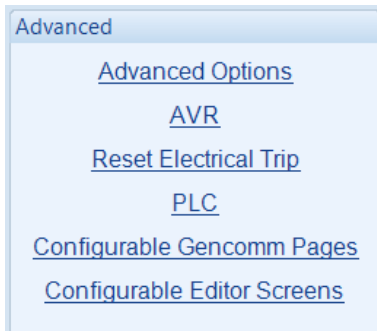

## 2.15.1 ADVANCED OPTIONS

### Protections

 **WARNING!** - Enabling this feature prevents the set being stopped upon critical alarm conditions. All shutdown alarms are disabled with the exception of EMERGENCY STOP which continues to operate.

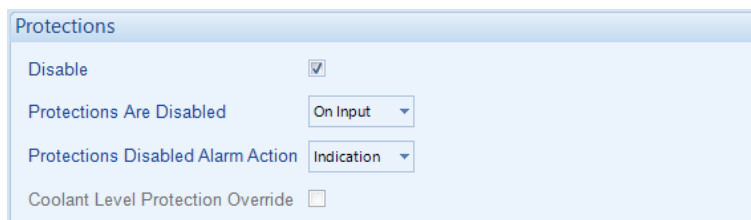

This feature is provided to assist the system designer in meeting specifications for “Warning only”, “Protections Disabled”, “Run to Destruction”, “Battleshort Mode” or other similar wording.

Parameter	Description
Disable	<p> <b>NOTE:</b> Writing a configuration to the controller that has “Protections Disabled” configured, results in a warning message appearing on the PC screen for the user to acknowledge before the controller’s configuration is changed. This prevents inadvertent activation of the feature.</p> <p><input type="checkbox"/> = The module operates as normal and provide engine shutdown if required.  <input checked="" type="checkbox"/> = <i>Protections disabled</i> function is activated. Operation depends upon the following configuration.</p>
Protections are disabled	<p><b>Never</b> : The protections are not disabled  <b>Always</b>: Protections are always overridden by the DSE controller.  <b>On Input</b>: Protections are disabled whenever a configurable input set to <i>Protections Disabled</i> is activated</p>
Protections Disabled Alarm Action	<p>If <i>Disable All Protections</i> is set to <i>On Input</i>, this selection allows configuration of an alarm to highlight that the protections have been disabled on the engine.  <b>Indication</b>: Any output or LCD display indicator configured to <i>Protections Disabled</i> is made active; however the internal alarm sound does not operate.  <b>Warning</b>: Any output or LCD display indicator configured to <i>Protections Disabled</i> is made active, and the internal alarm sound operates.                      When protections are disabled, <i>Protections Disabled</i> appears on the module display to inform the operator of this status.</p>
Coolant Level Protection Override	<p><input type="checkbox"/> = When a CANbus engine is selected, the <i>Coolant Level Protection</i> is provided when supported by the ECU (ECM).  <input checked="" type="checkbox"/> = The <i>Coolant Level Protection</i> is overridden and does not activate an alarm on the module</p>

**Out of Sync**

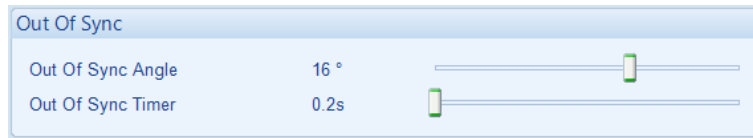

Parameter	Description
Out of Sync Angle	During parallel operation, the phase of both supplies is monitored. Being in parallel means that the phase difference is zero degrees (0 °) between the two supplies.  If the angle exceeds the <i>Out of Sync Angle</i> for longer than the duration of the <i>Out of Sync Timer</i> , an electrical trip alarm is generated taking the set off load and into the cooling timer, after which the set is stopped.

**Troubleshooting Out of Sync**

This sections describes the most common causes for an *Out of Sync* alarm:

- The *Bus Sensing* connections have not been made between the common generator bus and the DSE module, or the bus sensing fuses have blown or have been removed.
- The load switching device does not close quickly enough. Ensure the breaker closes within 100 ms of receiving the close signal.
- The *Out of Sync* timer is set too low. If this timer is raised away from the factory setting of 200 ms (0.2 s), ensure the consequences are fully understood.
- Something external has caused the breaker to open, or has prevented it from closing. Typical examples are external G59 relays and other equipment operating directly on the breaker to open it.
- The breaker wiring 'logic' is not correct, causing the breaker to 'fire through', where it triggers the close mechanism, but the breaker doesn't actually mechanically close, it re-opens again.

**Other Timers**

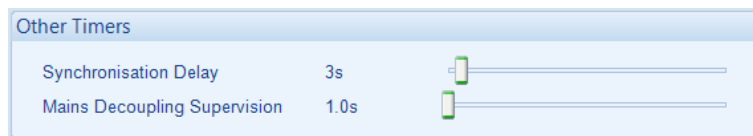

Parameter	Description
Synchronisation Delay	Delays the synchronising process to allow the set to stabilise and power parasitic loads or transformers (for instance) before the synchronising process begins.
Mains Decoupling Supervision	Delays the activation of the inbuilt Mains Decoupling detection when generator switchgear closes in in parallel with the mains. Upon closing into parallel, the timer is activated. After the timer has expired, the Mains decoupling protection becomes active.

**Dead Bus Synchronising**

**NOTE:** When using a DSE CAN AVR in a *Dead Bus Synchronising* application, the DSE module is capable of controlling the “*Alternator De-Excite*” via the CAN communication, ensure the “*De-Excite Mode*” is enabled in the DSE CAN AVR. For further details on the DSE CAN AVRs configuration refer to DSE Publication: *057-283 DSEA108 Software Manual* or *057-294 DSEA109 Software Manual* available on our website: [www.deepseaelectronics.com](http://www.deepseaelectronics.com)

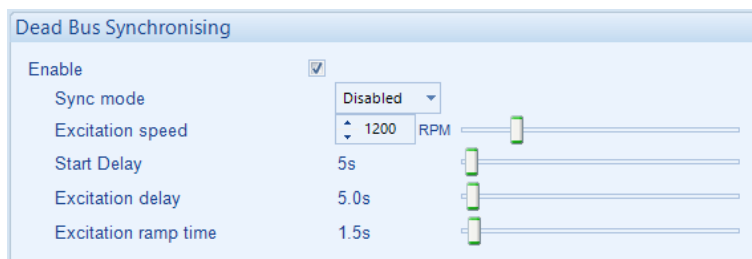

Parameter	Description
Enable	<input type="checkbox"/> = All synchronising is performed ‘the traditional’ way by achieving a slip frequency and waiting for the voltage, frequency and phase to be within configured windows <input checked="" type="checkbox"/> = The Dead Bus Synchronising feature is activated as configured below.
Sync Mode	<p><b>Always:</b> Dead bus sync is always used when the generators are required to be on line and in the <i>Auto</i> mode (Dead bus sync does not operate in <i>Manual</i> mode under any circumstance).</p> <p><b>Disabled:</b> The feature is not active</p> <p><b>On Input:</b> Dead bus sync is used when a digital input configured for <i>Remote Start Dead Bus Synchronising</i> is active.</p> <p><b>On Request From xx60:</b> Dead bus sync is only used when a start request is received from a DSExx60 module.</p>
Excitation Speed	The speed at which the engine is deemed to be running fast enough for the output configured as <i>De-Excite Alternator</i> to be de-energised. Any sets not reaching this speed by the end of the <i>Excitation Delay</i> open their breakers and are removed from the Dead Bus Sync System.
Start Delay	Time delay used at start up to ensure the start request is not simply a fleeting request.
Excitation Delay	During engine run up, if the <i>Excitation Speed</i> is not achieved by the end of the <i>Excitation Delay</i> , the set is removed from the Dead Bus Sync system and attempts to synchronise in the ‘traditional’ way.
Excitation Ramp Time	The time allowed for the excitation field to build after being energised. At the end of this time, all frequency and voltage alarms are active.

## 2.15.2 AVR

**NOTE:** At the time of writing, only the DSEA108 and DSEA109 AVRs are supported. The software versions of the DSEA108 & DSEA109 must be v2.0 or later. For further details, refer to DSE Publication: *057-281 DSEA108 Operator Manual* or *057-295 DSEA109 Operator Manual* available on our website: [www.deepseaelectronics.com](http://www.deepseaelectronics.com)

**NOTE:** The module's ECU port's baud rate is defined by the engine file selected in the *Application* section. Most engines' ECU baud rates are set to be 250 kb/s, ensure the baud rate of the AVR matches the engine ECU's baud rate.

This feature is to allow the DSE module communicate with a supported CAN AVR through its ECU port, to read the AVR instrumentations and to control the AVR for voltage matching during the synchronisation process and to control the reactive power during the load share.

### AVR Options

**AVR Options**

Enable AVR CAN Communications

AVR Type A108

AVR Source Address 230

Module CAN Address 36

Match AVR Alternative Configuration to Controller

Disable CAN Voltage Control

Parameter	Description
Enable AVR CAN Communications	<input type="checkbox"/> = Communications with the CAN AVR is disabled <input checked="" type="checkbox"/> = Enables communication with the CAN AVR through the ECU port.
AVR Type	Select the DSE CAN AVR connected to the module's ECU port. Options are: <ul style="list-style-type: none"> <li>• <b>A108</b></li> <li>• <b>A109</b></li> </ul>
AVR Source Address	<div style="border: 1px solid black; padding: 5px; margin-bottom: 5px;"> <p><b>NOTE:</b> For a full list of the AVR CAN message and instrumentation, refer to DSE Publication: <i>057-281 DSEA108 Operator Manual</i> or <i>057-295 DSEA109 Operator Manual</i> which is found on our website: <a href="http://www.deepseaelectronics.com">www.deepseaelectronics.com</a></p> </div> <div style="border: 1px solid black; padding: 5px; margin-bottom: 5px;"> <p><b>NOTE:</b> For further details on how to configure the DSEA108 CAN Source address, refer to DSE Publication: <i>057-283 DSEA108 Software Manual</i> or <i>057-294 DSEA109 Software Manual</i> which is available on our website: <a href="http://www.deepseaelectronics.com">www.deepseaelectronics.com</a></p> </div> <p>Set the AVR's <i>CAN Source Address</i> to communicate through.</p>
Module CAN Address	The CAN Source address used by the module when sending CAN messages to the AVR.

Parameter descriptions are continued overleaf...

Parameter	Description
Match AVR Alternative Configuration to Controller	<p><b>NOTE:</b> It is the engineer's responsibility to ensure that the DSE module's Alternative Configurations are within the correct range of the CAN AVR's Alternative Configurations. For further details on how to configure the DSEA108 or DSEA109 alternative configurations, refer to DSE Publication: <i>057-283 DSEA108 Software Manual</i> or <i>057-294 DSEA109 Software Manual</i> which is found on our website: <a href="http://www.deepseaelectronics.com">www.deepseaelectronics.com</a></p> <p>This feature is used to send a request to the CAN AVR to switch to an Alternative Configuration. If <i>Alt Config 1</i> is selected in the DSE Module, <i>Alt Config 1</i> is selected in the AVR too regardless of the configured values.</p> <p><input type="checkbox"/> = The module does not send an <i>Alternative Configuration</i> request to the CAN AVR.  <input checked="" type="checkbox"/> = The module sends an <i>Alternative Configuration</i> request to the CAN AVR when required.</p>
Disable CAN Voltage Control	<p><input type="checkbox"/> = The DSE module controls the AVR through the CAN communication. During the synchronisation process the DSE module controls the voltage through the CAN, and when load sharing it controls the reactive power through the CAN.  <input checked="" type="checkbox"/> = The DSE module CAN Voltage Control is disabled. The DSE module does not control the AVR through the CAN communication for voltage matching and does not control the reactive power through the CAN when load sharing.</p>

### AVR Data Fail

Indicates CAN communication failure between the module and the CAN AVR.

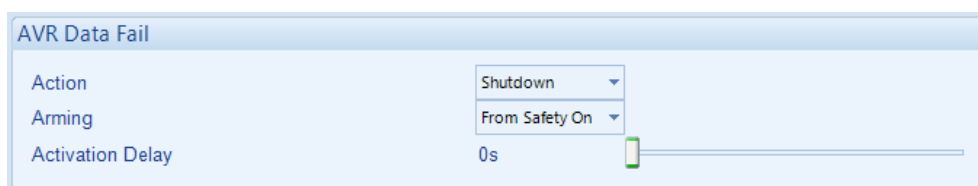

Parameter	Description
Action	Select the action to take when the module detects a communication failure with the CAN AVR. The options are: <b>Electrical Trip</b> <b>Indication</b> <b>Shutdown</b> <b>Warning</b>
Arming	Select when the <i>AVR Data Fail</i> is monitored.  Options are as follows: <b>Always:</b> The alarm is active at anytime the CAN Link is lost <b>From Safety On:</b> Active only after the <i>Safety On</i> delay timer <b>From Starting:</b> Active only after the <i>Crank Relay</i> is energised <b>Loading Alarms Activation:</b> The alarm is monitored after the generator is running, and the voltage and frequency are above their <i>Loading</i> levels, until the generator stops.
Activation Delay	The time delay for the module to wait before activating <i>AVR Data Fail</i> alarm when detected.

**AVR Fault**

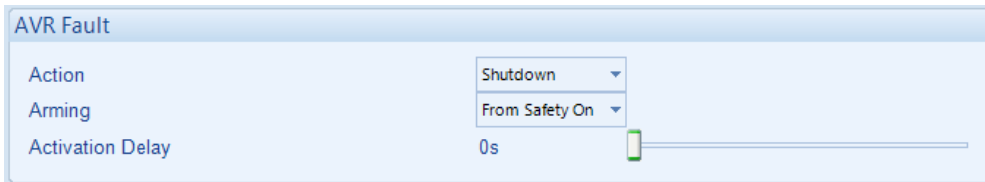

Parameter	Description
Action	Select the action to take after the <i>Activation Delay</i> timer, when the CAN AVR activates an alarm. The options are: <b>Electrical Trip</b> <b>Indication</b> <b>Shutdown</b> <b>Warning</b>
Arming	Select when the <i>AVR Fault</i> is monitored.  Options are as follows: <b>Always:</b> The alarm is active at anytime the CAN Link is lost <b>From Safety On:</b> Active only after the <i>Safety On</i> delay timer <b>From Starting:</b> Active only after the <i>Crank Relay</i> is energised
Activation Delay	The time delay for the module to wait before activating <i>AVR Fault</i> alarm when detected.

**AVR**

**NOTE:** Ensure the generator's AVR has a wide enough range of adjustment to cater for nominal voltage adjustment whilst not affecting normal voltage synchronising or kvar load sharing functionality.

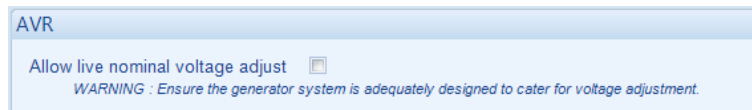



Parameter	Description
Allow Live Nominal Voltage Adjust	<input type="checkbox"/> = Adjustment of nominal voltage is disabled. <input checked="" type="checkbox"/> = The nominal voltage is adjusted through the running editor on the module display.

### 2.15.3 RESET ELECTRICAL TRIP

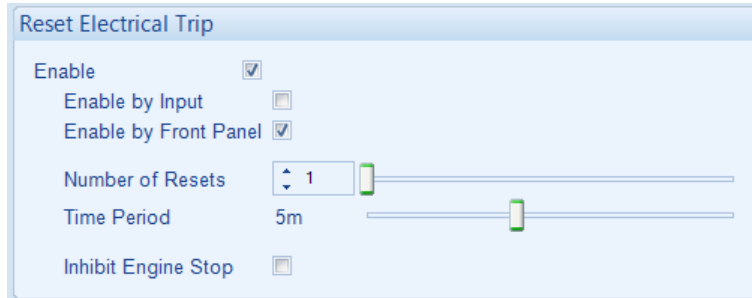
This feature is provided to assist the system designer in meeting specifications requirements to ensure the generator (if running) is able to take load again after the *Electrical Trip* alarm has been reset. Depending upon configuration, the generator may go into a cooling run or be inhibited from stopping after the *Electrical Trip* alarm activates.



Parameter	Description
Enable	<p><b>NOTE:</b> Writing a configuration to the controller that has <i>Reset Electrical Trip</i> enabled, results in a warning message appearing on the PC screen for the user to acknowledge before the controller's configuration is changed. This prevents inadvertent activation of the feature.</p> <p><input type="checkbox"/> = If an Electrical Trip alarm is reset, the generator must continue to cooldown before it becomes available again.  <input checked="" type="checkbox"/> = If an Electrical Trip alarm is reset, the generator is placed back on load if requested.</p>
Enable by Input	<p><b>NOTE:</b> Only possible to enable if an input is configured to <i>Reset Electrical Trip</i>.</p> <p><input type="checkbox"/> = <i>Reset Electrical Trip</i> only by pressing the <b>Close Generator</b>  button (if enabled).  <input checked="" type="checkbox"/> = <i>Reset Electrical Trip</i> by an input configured for <i>Reset Electrical Trip</i> and/or by pressing the <b>Close Generator</b>  button (if enabled).</p>
Enable by Front Panel	<p><input type="checkbox"/> = <i>Reset Electrical Trip</i> only by activating an input configured for <i>Reset Electrical Trip</i> (if enabled).  <input checked="" type="checkbox"/> = <i>Reset Electrical Trip</i> by pressing the <b>Close Generator</b>  button and/or activating an input configured for <i>Reset Electrical Trip</i> (if enabled).</p>
Number of Resets	The number of times any electrical trips can be reset whilst the generator is running to enable it to go back on load. The counter goes to zero upon the generator stopping.
Time Period	The time interval for the <i>Number of Resets</i> . If the <i>Number of Resets</i> is reached within configured <i>Time Period</i> , no more resets can occur until the generator has stopped.
Inhibit Engine Stop	<p><b>NOTE:</b> Writing a configuration to the controller that has <i>Inhibit Engine Stop</i> enabled, results in a warning message appearing on the PC screen for the user to acknowledge before the controller's configuration is changed. This prevents inadvertent activation of the feature.</p> <p><input type="checkbox"/> = When an Electrical Trip alarm activates, the generator's load switch opens and the generator goes into a cooling run before shutting down.  <input checked="" type="checkbox"/> = When an Electrical Trip alarm activates, the generator's load switch opens and the generator continues to run with the <i>Electrical Trip Stop Inhibited Warning</i> alarm active.</p>

## 2.15.4 PLC

**NOTE:** For further details and instructions on the *PLC Editor*, refer to DSE Publication: *057-314 Advanced PLC Software Manual* which is found on our website: [www.deepseaelectronics.com](http://www.deepseaelectronics.com)

**NOTE:** For the earlier software versions pre-V5 of the module, refer to DSE Publication: *057-175 PLC Programming Guide* which is found on our website: [www.deepseaelectronics.com](http://www.deepseaelectronics.com)

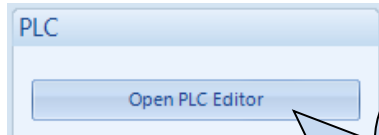

Click to open the *PLC Editor*, then the *PLC Editor* opens as shown below.

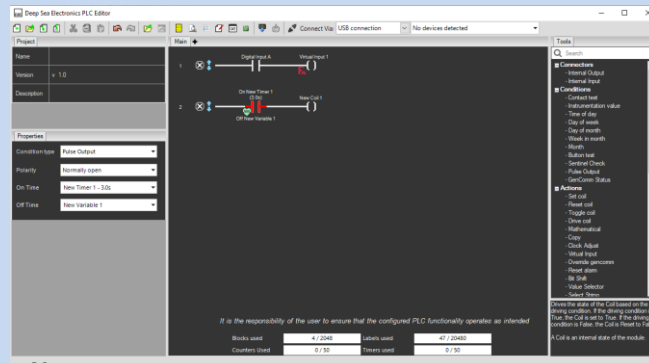

## 2.15.5 CONFIGURABLE GENCOMM PAGES 166 TO 169

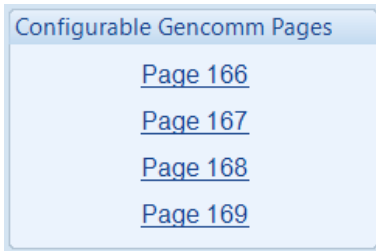

For advanced MODBUS users of the controller, configurable Gencomm pages are available. The intention is to allow the user to create personal collections of data in subsequent registers to minimise the number of MODBUS reads required by the master, and hence speed up data collection.

All configurable Gencomm registers are 32-bit unsigned format.

Gencomm Page 166							
Register	Value	Register	Value	Register	Value	Register	Value
0-1	<Not Used>	64-65	<Not Used>	128-129	<Not Used>	192-193	<Not Used>
2-3	<Not Used>	66-67	<Not Used>	130-131	<Not Used>	194-195	<Not Used>
4-5	<Not Used>	68-69	<Not Used>	132-133	<Not Used>	196-197	<Not Used>
6-7	<Not Used>	70-71	<Not Used>	134-135	<Not Used>	198-199	<Not Used>
8-9	<Not Used>	72-73	<Not Used>	136-137	<Not Used>	200-201	<Not Used>
10-11	<Not Used>	74-75	<Not Used>	138-139	<Not Used>	202-203	<Not Used>
12-13	<Not Used>	76-77	<Not Used>	140-141	<Not Used>	204-205	<Not Used>
14-15	<Not Used>	78-79	<Not Used>	142-143	<Not Used>	206-207	<Not Used>
16-17	<Not Used>	80-81	<Not Used>	144-145	<Not Used>	208-209	<Not Used>
18-19	<Not Used>	82-83	<Not Used>	146-147	<Not Used>	210-211	<Not Used>
20-21	<Not Used>	84-85	<Not Used>	148-149	<Not Used>	212-213	<Not Used>
22-23	<Not Used>	86-87	<Not Used>	150-151	<Not Used>	214-215	<Not Used>
24-25	<Not Used>	88-89	<Not Used>	152-153	<Not Used>	216-217	<Not Used>
26-27	<Not Used>	90-91	<Not Used>	154-155	<Not Used>	218-219	<Not Used>
28-29	<Not Used>	92-93	<Not Used>	156-157	<Not Used>	220-221	<Not Used>
30-31	<Not Used>	94-95	<Not Used>	158-159	<Not Used>	222-223	<Not Used>
32-33	<Not Used>	96-97	<Not Used>	160-161	<Not Used>	224-225	<Not Used>
34-35	<Not Used>	98-99	<Not Used>	162-163	<Not Used>	226-227	<Not Used>
36-37	<Not Used>	100-101	<Not Used>	164-165	<Not Used>	228-229	<Not Used>
38-39	<Not Used>	102-103	<Not Used>	166-167	<Not Used>	230-231	<Not Used>
40-41	<Not Used>	104-105	<Not Used>	168-169	<Not Used>	232-233	<Not Used>
42-43	<Not Used>	106-107	<Not Used>	170-171	<Not Used>	234-235	<Not Used>
44-45	<Not Used>	108-109	<Not Used>	172-173	<Not Used>	236-237	<Not Used>
46-47	<Not Used>	110-111	<Not Used>	174-175	<Not Used>	238-239	<Not Used>

The configurable MODBUS pages are:

Page	Hex Address	Decimal Address
166	A600	42496
167	A700	42752
168	A800	43008
169	A900	43264

**Example of Gencomm Page Configuration:**

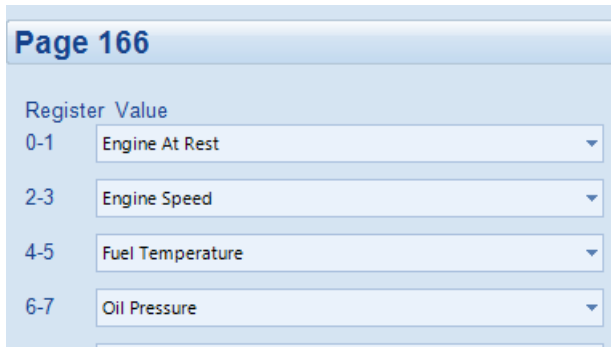

The screenshot shows a configuration page titled "Page 166". Under the heading "Register Value", there are four rows, each with a register address range and a dropdown menu:

Register Address	Register Value
0-1	Engine At Rest
2-3	Engine Speed
4-5	Fuel Temperature
6-7	Oil Pressure

The register address is obtained from the formula:  
 $register\_address = page\_number * 256 + register\_offset$ .

To read the *Engine Speed* from the above register, the MODBUS master device needs to read the data in two registers and then combine the data from the Most Significant Bit and the Least Significant Bit.

MSB address in Decimal =  $(166 * 256) + 2 = 42498$

LSB address in Decimal =  $(166 * 256) + 3 = 42499$

### 2.15.6 CONFIGURABLE EDITOR SCREENS

The *Configurable Editor Screens* enables the user to select six parameters to be editable through the module display. The editing of these parameters is not protected by the PIN (if enabled).

The screenshot shows a window titled "User Editable Module Parameters" with a light blue background. It contains six rows, each with a label "Editable Item X" and a dropdown menu. The dropdown menus are currently set to the following values: "Config Select", "Load Level Less Sets", "Load Level More Sets", "MSC Compatibility Enable", "Nominal Voltage", and "Nominal Frequency".

Parameter	Description
Editable Item 1 to 6	Select the required parameter to be shown and be editable from the module's screen.

### 3 SCADA

SCADA stands for Supervisory Control And Data Acquisition and is provided both as a service tool and also as a means of monitoring / controlling the generator set. As a service tool, the SCADA pages are to check the operation of the controller's inputs and outputs as well as checking the generators operating parameters.

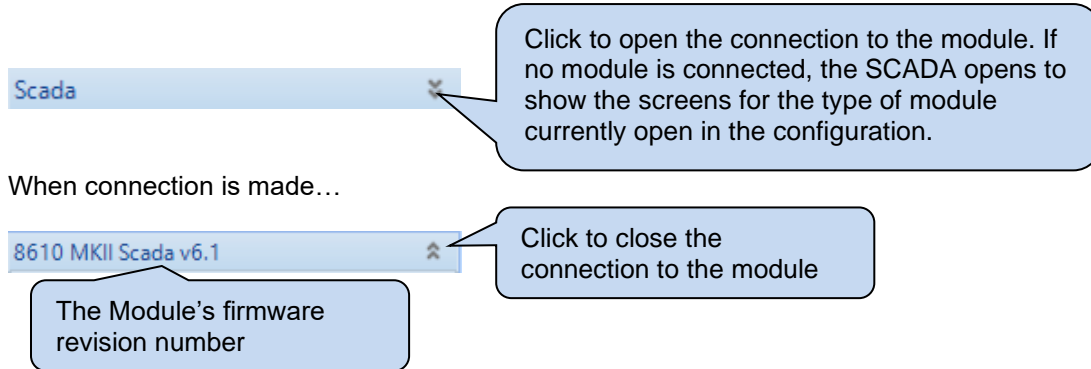

The SCADA page is subdivided into smaller sections. Select the required section with the mouse.

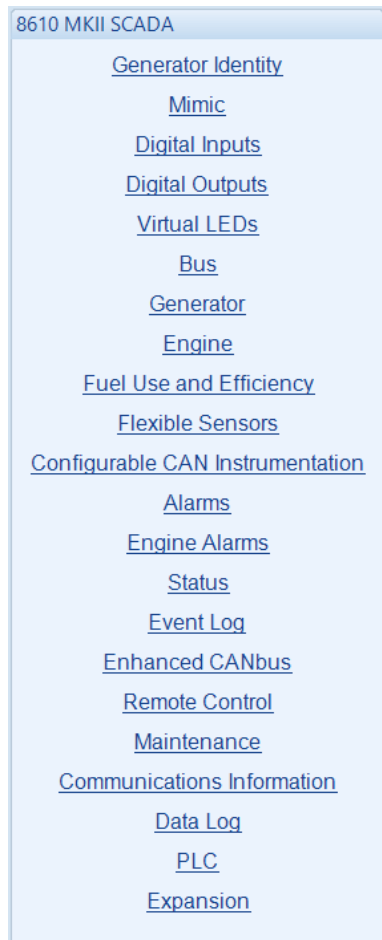

### 3.1 GENERATOR IDENTITY

This section displays the module's configuration settings for *Site ID* and *Genset ID*. For further details on how to configure these items, refer to section entitled *Communications Options* elsewhere within this document.

<b>Generator Identity</b>	
Site Identity	Deep Sea Electronics Head Office
Genset Identity	Volvo TAD941 GE

### 3.2 MIMIC

This section provides a mimic of the module's fascia and allows the operator to change the control mode of the module. For information in regards to operating the DSE module, refer to DSE publication: **057-254 DSE8610 MKII Operation Manual** which is found on the DSE website: [www.deepseaelectronics.com](http://www.deepseaelectronics.com)



**Hint:** Buttons may not operate if this has been locked out by the *Access Permissions* security feature of the Configuration Suite software. Refer to the system supplier for

Click the mimic buttons to control the module remotely

### 3.3 DIGITAL INPUTS

This section displays the status of the module's digital inputs and the functions they are configured for. For further details on how to configure these items, refer to section entitled *Digital Inputs* elsewhere within this document.

The screenshot shows a 'Digital Inputs' panel with the following data:

Label	Active	Open / Closed
A Remote Start On Load Demand	Green circle	Switch (open)
B Mains Parallel Mode	Green circle	Switch (open)
C Digital Input C	Green circle	Switch (open)
D Generator Closed Auxiliary	Green circle	Switch (open)
E Digital Input E	Green circle	Switch (open)
F Digital Input F	Green circle	Switch (open)
G Simulate Auto Button	Green circle	Switch (open)
H Digital Input H	Green circle	Switch (open)
I External Panel Lock	Green circle	Switch (open)
J Digital Input J	Green circle	Switch (open)
K Digital Input K	Green circle	Switch (open)
L Digital Input L	Green circle	Switch (open)
Emergency Stop	Red stop symbol	Switch (closed)

**Callout 1 (top left):** Shows if the input channel is active or not. This input is open and not active. The input is configured to be *Close to Activate*

**Callout 2 (middle right):** State of the input (open or closed to battery negative)

**Callout 3 (bottom):** State of the *Emergency Stop* input (open or closed to battery positive). This input **MUST** be closed to battery positive for *normal* operation. If the input is open, the generator is stopped if it's already running and not allowed to start.

### 3.4 DIGITAL OUTPUTS

This section displays the status of the module's digital outputs and the functions they are configured for. For further details on how to configure these items, refer to section entitled *Digital Outputs* elsewhere within this document.

Digital Outputs (Supplied From Emergency Stop Input)			
		Active	Open / Closed
A	Fuel Relay		
B	Start Relay		

Digital Outputs (Volts Free)			
		Active	Open / Closed
C (N/C)	Not Used		
D	Close Gen Output		

Digital Outputs (DC Supply Out)			
		Active	Open / Closed
E	ECU (ECM) Stop		
F	Generator Available		
G	ECU (ECM) Power		
H	Audible Alarm		
I	Not Used		
J	Not Used		
K	Not Used		
L	Not Used		

Shows if the output channel is active or not. This output is closed and is active. The output is configured to be *Generator Available Energise*. As the generator is available, the output is *Energised*.

### 3.5 VIRTUAL LEDS

This section displays the status of the module's *Virtual LEDs* and the functions they are configured for. These LEDs are not fitted to the module or expansion modules, they are not physical LEDs. They are provided to show status and appear only in the SCADA section of the DSE Configuration Suite, or read by third party PLC or Building Management Systems (for example) using the MODBUS protocol. For further details on how to configure these items, refer to section entitled *Digital Outputs* elsewhere within this document.

The screenshot shows a window titled "LED Status" with a list of 20 virtual LEDs. Each LED is associated with a specific function. To the right of the list is a vertical column of 20 green circular indicators. The word "Active" is positioned above the top indicator. Two callout boxes provide additional information: one points to the top indicator, stating "State of the LED (on or off)", and another points to the indicator for LED 6, stating "Shows what the virtual LED is configured to indicate.".

LED ID	Function	Status
LED 1	System In Auto Mode	Active
LED 2	Fuel Relay	Off
LED 3	Start Relay	Off
LED 4	Not Used	Off
LED 5	Common Alarm	Off
LED 6	Common Shutdown	Off
LED 7	Not Used	Off
LED 8	Not Used	Off
LED 9	Not Used	Off
LED 10	Not Used	Off
LED 11	Not Used	Off
LED 12	Not Used	Off
LED 13	Not Used	Off
LED 14	Not Used	Off
LED 15	Not Used	Off
LED 16	Not Used	Off
LED 17	Not Used	Off
LED 18	Not Used	Off
LED 19	Not Used	Off
LED 20	Not Used	Off

### 3.6 BUS

This section displays the module's measurement of the *Bus* supply and the *FRT event* counter.

Frequency		
50.06 Hz		

Phase Rotation		
L1-L2-L3		

Phase To Neutral Voltages		
L1 - N 230.0 V	L2 - N 229.2 V	L3 - N 231.4 V

Phase To Phase Voltages		
L1 - L2 397.4 V	L2 - L3 398.8 V	L3 - L1 400.0 V

Fault Ride Through		
5 Events		

### 3.7 GENERATOR

The *Generator* section is subdivided into smaller sections. Select the required section with the mouse.

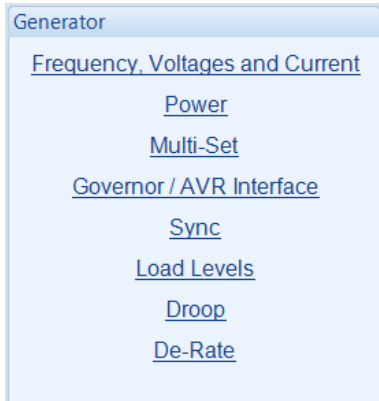

#### 3.7.1 FREQUENCY, VOLTAGES AND CURRENT

This section displays the module's measurement of the *Generator* frequency, voltage and current supply.

<b>Frequency</b>		
50.01 Hz		
<b>Phase To Neutral Voltages</b>		
L1 - N 240.1 V	L2 - N 240.1 V	L3 - N 240.2 V
<b>Phase To Phase Voltages</b>		
L1 - L2 415.9 V	L2 - L3 415.0 V	L3 - L1 415.4 V
<b>Current</b>		
L1 36.0 A	L2 36.0 A	L3 36.0 A
<b>Earth Current</b>		
0.0 A		
<b>Phase Rotation</b>		
L1-L2-L3		

### 3.7.2 POWER

This section displays the module's measurement of the *Power* the *Generator* is supplying.

Watts			
L1	L2	L3	Total
8.62 kW	8.67 kW	8.62 kW	25.91 kW
9.9 %	10.0 %	9.9 %	9.9 %

VA			
L1	L2	L3	Total
8.6 kVA	8.7 kVA	8.7 kVA	26.0 kVA

VAr			
L1	L2	L3	Total
0.1 kVAr	0.0 kVAr	0.1 kVAr	0.2 kVAr

Power factor			
L1	L2	L3	Average
0.99	1.00	1.00	0.99

Accumulated Power			
-kWh	kWh	kVAh	kVArh
	69036.7 kWh	75913.8 kVAh	8096.8 kVArh

### 3.7.3 MULTI-SET

**NOTE:** These settings are not saved within the module’s configuration file. They are stored in a different memory area and not transferred with the configuration file. The *Backup Module* feature transfers both the configuration file AND the settings of the Multi-set, Governor / AVR interface and Sync page.

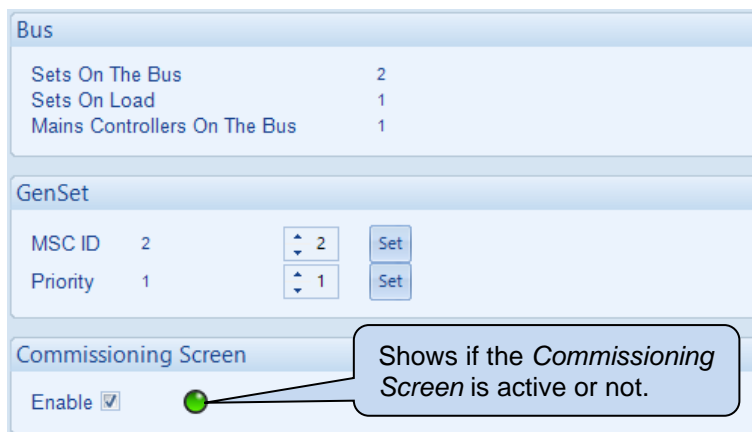

#### Bus

Parameter	Description
Set On The Bus	The number of DSExx10 controllers that are connected on the MSC link.
Sets On Load	The number of DSExx10 controllers that are connected on the MSC link and closed onto the generator bus.
Mains Controllers On The Bus	The number of DSExx60 and DSExx80 controllers that are connected on the MSC link.

#### GenSet

Parameter	Description
MSC ID	Select the MSC ID of the DSE module’s MSC port. Every module connected on the MSC link must have a unique MSC ID. The MSC ID is automatically set when all the modules are powered up “one at a time”. If all the modules a powered up together, this may result in the <i>MSC ID Error</i> alarm activating. Manually setting the MSC ID allows this alarm to be reset and prevents this from occurring.
Priority	<div style="border: 2px solid black; padding: 5px; margin-bottom: 5px;"> <p><b>NOTE:</b> For further details and instructions on the <i>DSE Load Demand Scheme</i>, refer to DSE Publication: <i>056-013 Load Demand Scheme</i> which is found on our website: <a href="http://www.deepseaelectronics.com">www.deepseaelectronics.com</a></p> </div> <p>Select the Priority of the module when running on the <i>Load Demand Scheme</i>. Every device on the MSC link must have an individual MSC ID.</p>

#### Commissioning Screen

Parameter	Description
Enable	<input type="checkbox"/> = Commissioning screens are not shown on the module display <input checked="" type="checkbox"/> = The commissioning screens are shown at the bottom of the <i>Generator</i> section on the module display. These pages are useful for the commissioning and troubleshooting of a load share system.

### 3.7.4 GOVERNOR / AVR INTERFACE

**NOTE:** These settings are not saved within the module's configuration file. They are stored in a different memory area and not transferred with the configuration file. The **Backup Module** feature transfers both the configuration file AND the settings of the Multi-set, Governor / AVR interface and Sync page.

This section allows the user to calibrate the SW1 (Switch 1) and SW2 (Switch 2) settings for the *Analogue Governor Output* and *Analogue AVR Output* which the DSE module uses to control synchronising and load sharing. For information in regards to calibrating these settings, refer to DSE publication: **057-254 DSE8610 MKII Operation Manual** which is found on the DSE website: [www.deepseaelectronics.com](http://www.deepseaelectronics.com).

As the input requirements of governors and AVRs vary from manufacturer to manufacturer, and even from model to model, the DSE module is configurable to allow connection to these devices. For information in regards to typical wiring diagrams and suggested SW1 / SW2 settings for common governors and AVRs, refer to DSE publication: **057-046 DSE Guide to Synchronising and Load Sharing (Part 2)** which is found on the DSE website: [www.deepseaelectronics.com](http://www.deepseaelectronics.com).

**Governor**

Centre (SW1) 4.9  4.9

Range (SW2) 6.8  6.8

**Speed And Frequency**

Engine Speed	1499 RPM
Generator Frequency	49.98 Hz
Governor Analogue	3.0 %
AVR Analog	-1.1 %

Governor and AVR Analogue percentage of drive.

**AVR**

Centre (SW1) 0.0  0.0

Range (SW2) 7.0  7.0

**Phase To Neutral Voltages**

L1 - N	L2 - N	L3 - N
239.9 V	240.3 V	239.8 V

**Phase To Phase Voltages**

L1 - L2	L2 - L3	L3 - L1
416.8 V	415.8 V	415.3 V

#### 3.7.4.1 SW1

SW1 is also known as *Centre*. SW1 sets the voltage produced by the DSE module's *Analogue Governor / AVR Outputs* for 'nominal' running condition. For example SW1 = 5 for the *Analogue Governor Output*, means that the *Analogue Governor Output* is 2.5 V<sub>DC</sub> when the generator is required to run at it's nominal speed.

### 3.7.4.2 SW2

SW2 is also known as *Range*. SW2 sets the range of adjustment around the SW1 (*Centre*) voltage to adjust engine speed or generator voltage away from nominal conditions. For example SW2 = 3 for the *Analogue Governor Output*, means that the *Analogue Governor Output* is made to change by  $\pm 2 V_{DC}$  around the SW1 (*Centre*) voltage to make the engine run at lower/higher speed to synchronise or to increase/decrease kW for load sharing.

### 3.7.4.3 SETTINGS

The *Analogue Governor Output* and *Analogue AVR Output* are both isolated from ground and battery negative, allowing compatibility with devices with inputs that are not referenced to ground or battery negative. The tables below specify the relationship between the SW1 / SW2 setting and the voltage set point.

SW1 Setting	Centre Voltage of Analogue Output
0	0.0 V <sub>DC</sub>
1	0.5 V <sub>DC</sub>
2	1.0 V <sub>DC</sub>
3	1.5 V <sub>DC</sub>
4	2.0 V <sub>DC</sub>
5	2.5 V <sub>DC</sub>
6	3.0 V <sub>DC</sub>
7	3.5 V <sub>DC</sub>
8	4.0 V <sub>DC</sub>
9	4.5 V <sub>DC</sub>

SW2 Setting	Voltage Range of Analogue Output
0	$\pm 0.5 V_{DC}$
1	$\pm 1.0 V_{DC}$
2	$\pm 1.5 V_{DC}$
3	$\pm 2.0 V_{DC}$
4	$\pm 2.5 V_{DC}$
5	$\pm 3.0 V_{DC}$
6	$\pm 3.5 V_{DC}$
7	$\pm 4.0 V_{DC}$
8	$\pm 4.5 V_{DC}$
9	$\pm 5.0 V_{DC}$

### 3.7.4.4 SUMMARY

Consider the settings for the *Analogue Governor / AVR Output* as  $SW1 \pm SW2$

In the example mentioned previously this means the *Analogue Governor Output* is  $2.5 V_{DC} \pm 2 V_{DC}$  (based upon the settings of SW1 = 5 and SW2 = 3), effectively giving a range of adjustment between 0.5 V<sub>DC</sub> to 4.5 V<sub>DC</sub>.

SW1 is the voltage above or below 0 V<sub>DC</sub> that the *Analogue Governor / AVR Output* produces to instruct the generator to operate at 'nominal' running condition

SW2 is the maximum voltage adjustment above and below SW1 that the *Analogue Governor / AVR Output* produces to instruct the voltage / frequency of the generator to change.

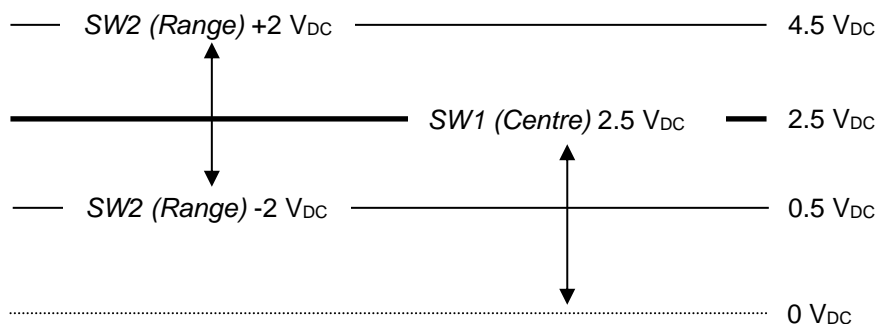

### 3.7.5 SYNC

The *Sync* section is subdivided into smaller sections. Select the required section with the mouse.

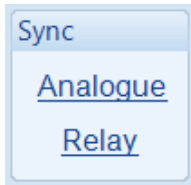

#### 3.7.5.1 ANALOGUE

##### Governor / AVR Interface

This section displays how the DSE module is set up to control the generators governor and AVR. For further details on how to configure these items, refer to section entitled *Sync Options* elsewhere within this document.

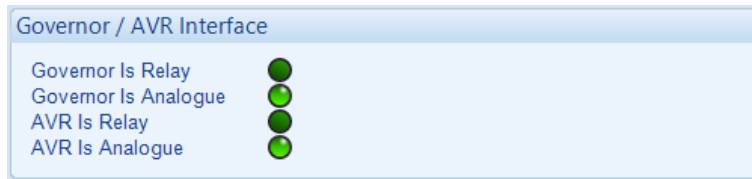

Parameter	Description
Governor Is Relay	<ul style="list-style-type: none"> <li> = The governor interface has been configured for Internal Analogue.</li> <li> = The governor interface has been configured for Internal Relays. In this case the <i>Relay</i> section's <i>Frequency Synchroniser</i> and <i>Governor Load Share</i> settings are available.</li> </ul>
Governor Is Analogue	<ul style="list-style-type: none"> <li> = The governor interface has been configured for Internal Relays.</li> <li> = The governor interface has been configured for Internal Analogue. In this case the <i>Analogue</i> section's <i>Frequency Synchroniser</i>, and <i>Governor Load Share &amp; Mains Parallel Mode</i> settings are available.</li> </ul>
AVR Is Relay	<ul style="list-style-type: none"> <li> = The AVR interface has been configured for Internal Analogue.</li> <li> = The AVR interface has been configured for Internal Relays. In this case the <i>Relay</i> section's <i>Voltage Matcher</i> and <i>AVR Load Share</i> settings are available.</li> </ul>
AVR Is Analogue	<ul style="list-style-type: none"> <li> = The AVR interface has been configured for Internal Relays.</li> <li> = The AVR interface has been configured for Internal Analogue. In this case the <i>Analogue</i> section's <i>Voltage Matcher</i>, and <i>AVR Load Share &amp; Mains Parallel Mode</i> settings are available.</li> </ul>

**Frequency Synchroniser**

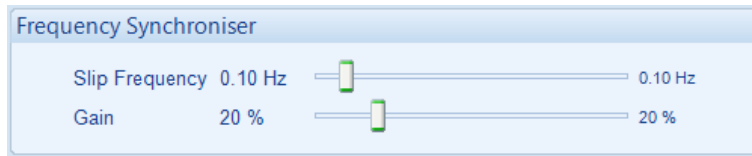

Parameter	Description
Slip Frequency	This is the frequency difference between the generator and the bus which the module adjusts to during synchronising. This is done to match the phase of the generator supply to bus supply. The phase of the supplies then drifts in and out of synchronism at a rate of $1/Slip\ Frequency$ times per second. e.g. with a <i>Slip Frequency</i> of 0.2 Hz, the supplies are in phase once every five seconds.
Gain	The setting for the gain of the control loop used for the frequency synchroniser. In general, a lower setting results in a slow frequency matching process. Having a high a setting may cause instability (hunting), if this occurs lower the gain setting.

**Voltage Matcher**



Parameter	Description
Gain	The setting for the gain of the control loop used for the voltage synchroniser. In general, a lower setting results in a slow frequency matching process. Having a high a setting may cause instability (hunting), if this occurs lower the gain setting.

**Load Share Mode**

For information in regard to calibrating these settings, refer section entitled *Adjusting Gain (P), Stability (I) and Derivative (D)* elsewhere within this document.

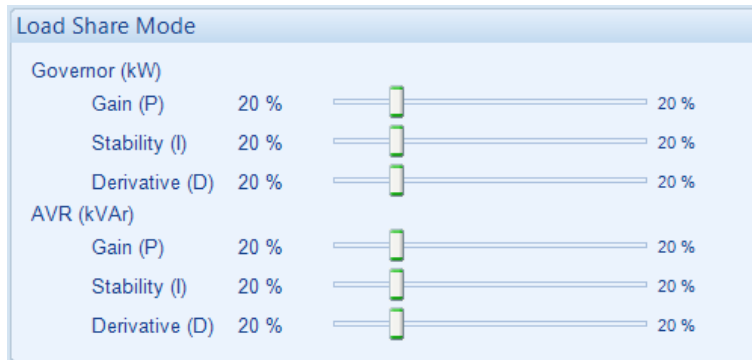

Parameter	Description
Governor (kW) Gain (P) Stability (I) Derivative (D)	The setting for the Gain (P), Stability (I) and Derivative (D) of the control loop used for the isochronous kW load sharing.
AVR (kvar) Gain (P) Stability (I) Derivative (D)	The setting for the Gain (P), Stability (I) and Derivative (D) of the control loop used for the isochronous kvar load sharing.

**Mains Parallel Mode**

**NOTE:** The *Mains Parallel Mode* PID settings only have effect when a digital input is configured for *Mains Parallel Mode* instructing the module to operate in fixed export mode with the utility supply. For more information on this application, refer to DSE Publication: *056-054 DSE8x10 in Fixed Export (Base Load)* which is found on our website: [www.deepseaelectronics.com](http://www.deepseaelectronics.com)

The user has the ability to configure different *Gain (P)*, *Stability (I)* and *Derivative (D)* settings for *Mains Parallel Operation*. Typically, engine governors need lower gain when in parallel with the Mains supply than they do for single set operation or paralleling with other generators.

For information in regard to calibrating these settings, refer section entitled *Adjusting Gain (P)*, *Stability (I)* and *Derivative (D)* elsewhere within this document.

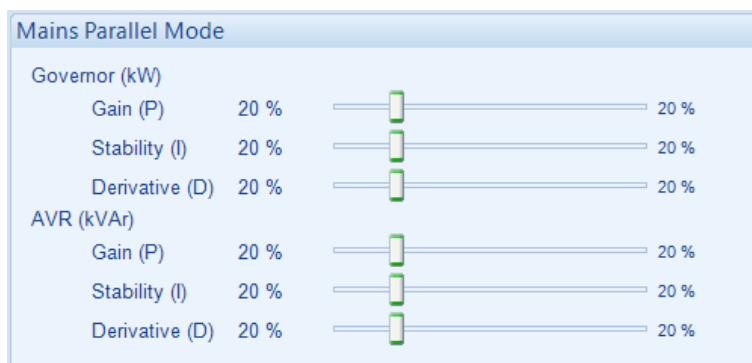

Parameter	Description
Governor (kW) Gain (P) Stability (I) Derivative (D)	The setting for the <i>Gain (P)</i> , <i>Stability (I)</i> and <i>Derivative (D)</i> of the control loop used for the kW control when running in <i>Mains Parallel Mode</i> .
AVR (kvar) Gain (P) Stability (I) Derivative (D)	The setting for the <i>Gain (P)</i> , <i>Stability (I)</i> and <i>Derivative (D)</i> of the control loop used for the kvar control when running in <i>Mains Parallel Mode</i> .

### 3.7.5.1.1 ADJUSTING GAIN (P), STABILITY (I) AND DERIVATIVE (D)

#### Initial Setup

In most cases the DSE factory settings of 20% for *Gain (P)*, *Stability (I)* and 0 % for *Derivative (D)* are suitable for most systems. This is because the DSE module's control is limited by the *Gain (P)*, *Stability (I)* and *Derivative (D)* settings of the engine's governor / alternator's AVR. Before adjusting the DSE module's settings, adjust the *Gain (P)*, *Stability (I)* and *Derivative (D)* settings of the engine's governor / alternator's AVR in accordance with the manufacturer's recommendations.

#### Calibration

If the loadsharing response of the system is not satisfactory after adjusting the *Gain (P)*, *Stability (I)* and *Derivative (D)* settings of the engine's governor / alternator's AVR, then start to adjust the DSE's settings by:

1. Starting with the *Gain (P)*, *Stability (I)* at 5 % and *Derivative (D)* at 0%. Place the generators in parallel with no load.
2. Gradually increase the *Gain (P)* setting until the generator power production becomes unstable. Very slowly decrease the *Gain (P)* setting, until the power production stabilises. Reduce the setting further by approximately 10 %.
3. Gradually increase the *Stability (I)* setting until the generator power production becomes unstable. Very slowly decrease the *Stability (I)* setting, until the power production stabilises.
4. Apply and remove load to the generators using a loadbank to test response and ensure no oscillation of power between generators. If a load bank is not available repeat the synchronising process several times to see the effect of the changes. Also attempt to 'knock' the governor actuator or change the 'slip frequency' setting to disturb the engine speed and force the controller into making further changes.
5. To improve the load change reponse, increase the *Derivative (D)* setting to decrease the overshoot and settling time.

The affect the *Gain (P)*, *Stability (I)* and *Derivative (D)* settings have on the response of a load step being applied to the generator are shown below.

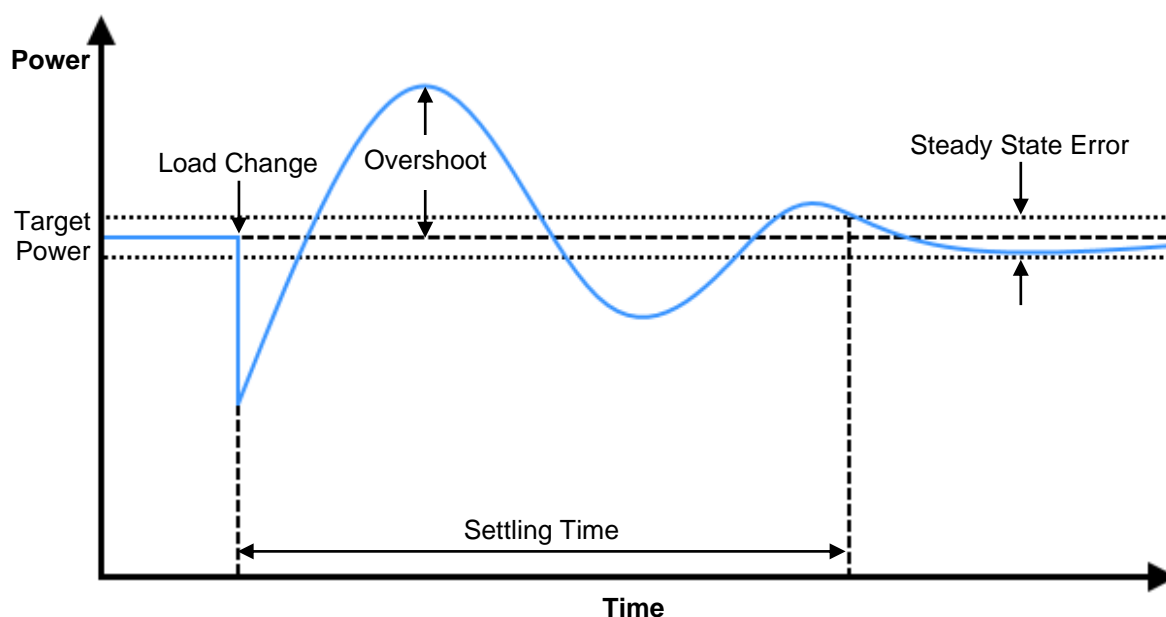

PID Adjustment	Overshoot	Settling Time	Steady State Error
Increase Gain (P)	Increases	Minimal Effect	Decreases
Increase Stability (I)	Increases	Increases	Eliminates
Increase Derivative (D)	Decrease	Decreases	No Effect

## Troubleshooting

 **NOTE: An over damped response results in a slower control process. An under damped response (overshooting the target) leads to an unstable control process. Either case leads to undesirable consequences such as overcurrent or reverse power, resulting in generator shutdown, and loss of supply to the load.**

If the load is oscillating quickly between the generators it suggests that the setting for the *Gain (P)* on the generator(s) is too high or too low. A slow rolling oscillation usually indicates that the *Stability (I)* is too high or too low. These oscillations are caused by incorrect settings on the engine's governor / alternator's AVR and/or the DSE module.

It is possible for the loadsharing stability to change as different generators are go in and out of parallel with one another. Ensure that the *Gain (P)*, *Stability (I)* and *Derivative (D)* are calibrated to give a stable condition when all generators are running in parallel.

### 3.7.5.2 RELAY

#### Governor / AVR Interface

This section displays how the DSE module is set up to control the generators governor and AVR. For further details on how to configure these items, refer to section entitled *Sync Options* elsewhere within this document.



Parameter	Description
Governor Is Relay	<ul style="list-style-type: none"> <li><input checked="" type="radio"/> = The governor interface has been configured for Internal Analogue.</li> <li><input type="radio"/> = The governor interface has been configured for Internal Relays. In this case the <i>Relay</i> section's <i>Frequency Synchroniser</i> and <i>Governor Load Share</i> settings are available.</li> </ul>
Governor Is Analogue	<ul style="list-style-type: none"> <li><input type="radio"/> = The governor interface has been configured for Internal Relays.</li> <li><input checked="" type="radio"/> = The governor interface has been configured for Internal Analogue. In this case the <i>Analogue</i> section's <i>Frequency Synchroniser</i>, and <i>Governor Load Share &amp; Mains Parallel Mode</i> settings are available.</li> </ul>
AVR Is Relay	<ul style="list-style-type: none"> <li><input type="radio"/> = The AVR interface has been configured for Internal Analogue.</li> <li><input checked="" type="radio"/> = The AVR interface has been configured for Internal Relays. In this case the <i>Relay</i> section's <i>Voltage Matcher</i> and <i>AVR Load Share</i> settings are available.</li> </ul>
AVR Is Analogue	<ul style="list-style-type: none"> <li><input checked="" type="radio"/> = The AVR interface has been configured for Internal Relays.</li> <li><input type="radio"/> = The AVR interface has been configured for Internal Analogue. In this case the <i>Analogue</i> section's <i>Voltage Matcher</i>, and <i>AVR Load Share &amp; Mains Parallel Mode</i> settings are available.</li> </ul>

#### Frequency Synchroniser

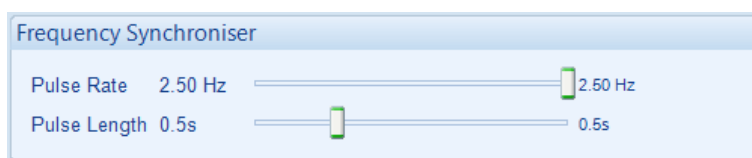

Parameter	Description
Pulse Rate	The rate at which the <i>Speed Raise</i> and <i>Speed Lower</i> outputs activate to maintain nominal frequency. A setting of 2.5 Hz results in the <i>Speed Raise</i> and <i>Speed Lower</i> outputs activating every 0.4 seconds (1/Hz). The pulse rate is the equivalent setting to <i>Gain</i> for PID control.
Pulse Length	The duration which the <i>Speed Raise</i> and <i>Speed Lower</i> outputs remain active for when maintaining nominal frequency. The pulse length is the equivalent setting to <i>Stability</i> for PID control.

**Voltage Matcher**

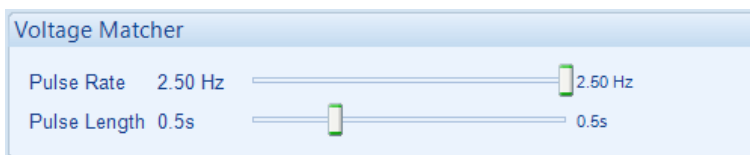

Parameter	Description
Pulse Rate	The rate at which the <i>Voltage Raise</i> and <i>Voltage Lower</i> outputs activate to maintain nominal voltage. A setting of 2.5 Hz results in the <i>Voltage Raise</i> and <i>Voltage Lower</i> outputs activating every 0.4 seconds (1/Hz). The pulse rate is the equivalent setting to Gain for PID control.
Pulse Length	The duration which the <i>Voltage Raise</i> and <i>Voltage Lower</i> outputs remain active for when maintaining nominal voltage. The pulse length is the equivalent setting to Stability for PID control.

**Load Control**

The same *Pulse Rate* and *Pulse Length* settings are used when using the Raise and Lower outputs to control the generator's power when in parallel.

For information in regard to calibrating these settings, refer section entitled *Adjusting Gain (P), Stability (I) and Derivative (D)* elsewhere within this document.

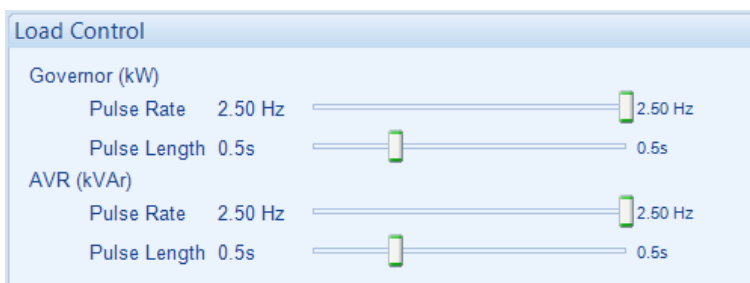

Parameter	Description
Governor (kW) Pulse Rate	The rate at which the <i>Speed Raise</i> and <i>Speed Lower</i> outputs activate to adjust the kW output of the generator. A setting of 2.5 Hz results in the <i>Speed Raise</i> and <i>Speed Lower</i> outputs activating every 0.4 seconds (1/Hz). The pulse rate is the equivalent setting to Gain for PID control.
Governor (kW) Pulse Length	The duration which the <i>Speed Raise</i> and <i>Speed Lower</i> outputs remain active for when adjusting the kW output of the generator. The pulse length is the equivalent setting to Stability for PID control.
AVR (kvar) Pulse Rate	The rate at which the <i>Voltage Raise</i> and <i>Voltage Lower</i> outputs activate to adjust the kvar output of the generator. A setting of 2.5 Hz results in the <i>Voltage Raise</i> and <i>Voltage Lower</i> outputs activating every 0.4 seconds (1/Hz). The pulse rate is the equivalent setting to Gain for PID control.
AVR (kvar) Pulse Length	The duration which the <i>Voltage Raise</i> and <i>Voltage Lower</i> outputs remain active when adjusting the kvar output of the generator. The pulse length is the equivalent setting to Stability for PID control.

### 3.7.6 LOAD LEVELS

#### Analogue Drive

Analogue Drive	
Governor	0.0 %
AVR	0.0 %

Parameter	Description
Governor Analogue Drive	<p>Shows the percentage of the module's range of adjustment over the governor (set by SW2) to run the generator at the required frequency or kW level for load sharing.</p> <p>For example, with an SW2 = 3 (<math>\pm 2 V_{DC}</math>) for the <i>Analogue Governor Output</i> and a <i>Governor Analogue Drive Percentage</i> = -50% , means that the <i>Analogue Governor Output</i> is made to change by -1 <math>V_{DC}</math> from the SW1 (Centre) voltage</p> <p>Typical magnitudes at full load, with the switchgear closed and running in <i>Isochronous Load Sharing</i> or <i>Mains Parallel Mode</i> operation are as follows:</p> <ul style="list-style-type: none"> <li>• No more than 10% when there is no external governor droop enabled</li> <li>• No more than 30% when external governor droop is enabled</li> </ul> <p>Typical magnitude at no load, with the switchgear closed and <i>Frequency Droop</i> enabled within the module's configuration are follows:</p> <ul style="list-style-type: none"> <li>• No more than 85%</li> </ul>
AVR Analogue Drive	<p>Shows the percentage of the module's range of adjustment over the AVR (set by SW2) to run the generator at the required voltage or kvar level for load sharing.</p> <p>For example, with an SW2 = 3 (<math>\pm 2 V_{DC}</math>) for the <i>Analogue AVR Output</i> and a <i>AVR Analogue Drive Percentage</i> = +75% , means that the <i>Analogue AVR Output</i> is made to change by +1.5 <math>V_{DC}</math> from the SW1 (Centre) voltage</p> <p>Typical magnitudes at full load, with the switchgear closed and running in <i>Isochronous Load Sharing</i> or <i>Mains Parallel Mode</i> operation are as follows:</p> <ul style="list-style-type: none"> <li>• No more than 10% when there is no external AVR droop enabled</li> <li>• No more than 30% when external AVR droop is enabled</li> </ul> <p>Typical magnitude at no load, with the switchgear closed and <i>Voltage Droop</i> enabled within the module's configuration are follows:</p> <ul style="list-style-type: none"> <li>• No more than 85%</li> </ul>

**Levels**

**NOTE:** The *Load Level* settings (excluding the *Minimum Load Level* setting) only have effect when a digital input is configured for *Mains Parallel Mode* instructing the module to operate in fixed export mode with the utility supply. For more information on this application, refer to DSE Publication: *056-054 DSE8x10 in Fixed Export (Base Load)* which is found on our website: [www.deepseaelectronics.com](http://www.deepseaelectronics.com)

For further details on how to configure the different power modes and their operation, refer to section entitled *Power Control* and *Voltage and Reactive Power Control* elsewhere within this document.

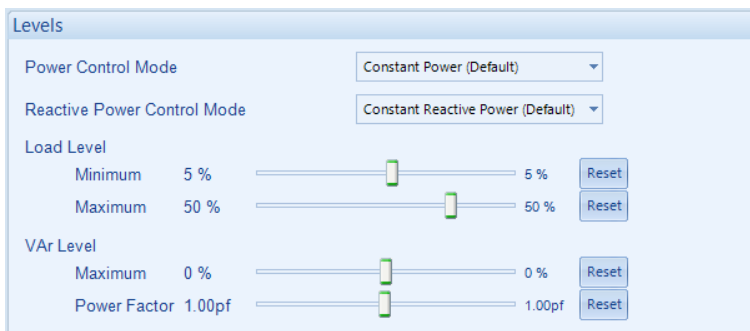

Parameter	Description
Power Control Mode	Allows selection of the <i>Power Control Mode</i> when running in <i>Mains Parallel Mode</i> . This is also selectable by activation of a configured digital input or via the <i>Running Editor</i> .
Reactive Power Control Mode	Allows selection of the <i>Reactive Power Control Mode</i> when running in <i>Mains Parallel Mode</i> . This is also selectable by activation of a configured digital input or via the <i>Running Editor</i> .
Minimum Load Level	The kW load level the generator starts to ramp from when its switchgear closes. It is also the kW load level when the generator's switchgear opens during ramping down and going off load.
Maximum Load Level	The maximum kW load level to be produced when running in <i>Mains Parallel Mode</i> .
Maximum var Level	The maximum kvar load level to be produced when running in <i>Mains Parallel Mode</i> .
Power Factor	The power factor the generator is to maintain when running in <i>Mains Parallel Mode</i>

**Ramp Rates**

**NOTE:** These adjustable parameters do not change the module’s configuration settings. These settings enable the user to change the values dynamically via SCADA or the module’s internal PLC based on operating requirements.

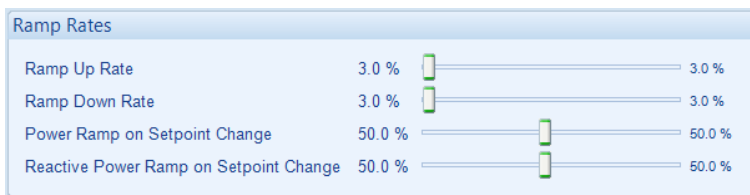

Parameter	Description
Ramp Up Rate	The rate at which the generator is ramped onto the load when not running in droop.
Ramp Down Rate	The rate at which the generator is ramped off the load when not running in droop.
Power Ramp on Setpoint Change	When changing between <i>Power Control</i> modes or changing the set point, the <i>Ramp Rate</i> defines how fast the output power changes in percentage points per second.
Reactive Power Ramp on Setpoint Change	When changing between <i>Reactive Power Control</i> modes or changing the set point, the <i>Ramp Rate</i> defines how fast the output power changes in percentage points per second.

### 3.7.7 DROOP

**NOTE:** The *Droop* PI settings only take affect when the unit is configured to operate in *Droop* mode. For further details on how the different methods to enable *Droop*, refer to section entitled *Load Control* elsewhere within this document.

The user has the ability to configure different *Gain (P)* and *Stability (I)* settings for *Droop Operation*. For information regarding calibrating these settings, refer section entitled *Adjusting Gain (P), Stability (I) and Derivative (D)* elsewhere within this document.

#### Frequency Droop

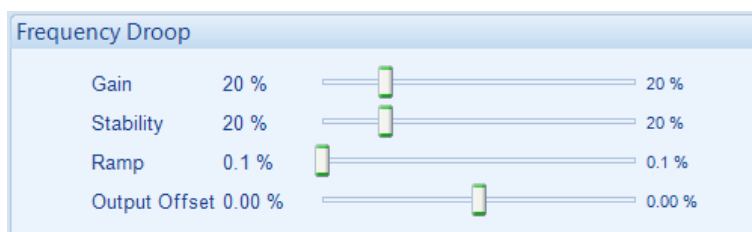

Parameter	Description
Gain (P) Stability (I)	The setting for the <i>Gain (P)</i> and <i>Stability (I)</i> of the control loop used for the frequency / kW control when running in <i>Droop</i> .
Ramp	The rate at which the generator kW is ramped onto and off the load when using <i>Droop</i> .
Output Offset	A positive/negative offset that is applied across the entire <i>Frequency Droop Curve</i> as percentage <i>Nominal Frequency</i> setting.  An <i>Output Offset</i> of +2% with a <i>Nominal Frequency</i> of 50 Hz would result in the entire <i>Frequency Droop Curve</i> being offset by 1 Hz.

#### Voltage Droop

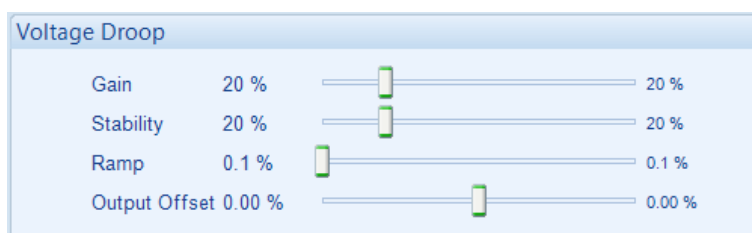

Parameter	Description
Gain (P) Stability (I)	The setting for the <i>Gain (P)</i> and <i>Stability (I)</i> of the control loop used for the voltage / kvar control when running in <i>Droop</i> .
Ramp	The rate at which the generator kvar is ramped onto and off the load when using <i>Droop</i> .
Output Offset	A positive/negative offset that is applied to the entire <i>Voltage Droop Curve</i> as percentage <i>Nominal Voltage</i> setting.  An <i>Output Offset</i> of -1% with a <i>Nominal Voltage</i> of 400 V would result in the entire <i>Voltage Droop Curve</i> being offset by -4 V.

### 3.7.8 DE-RATE

#### Watts

The screenshot shows a control panel titled 'Watts'. It contains four rows of data: 'De-Rate' is set to 80% with a slider; 'Current De-Rated Power %' is 80%; 'Configured Power Rating' is 500 kW; and 'Current De-Rated Power Rating' is 400 kW.

Parameter	Description
De-Rate	Select with the mouse and move the cursor to override the De-Rate % to the desired level. 100% represents Full kw Load Rating. Reducing the % reduces the generator's kw capacity to limit the power produced when in Mains Parallel Mode, or when load sharing over the MSC.
Current De-Rated Power %	The de-rated kw power in percent (%).
Configured Power Rating	The kW Rating of the generator, as configured in the <i>Generator Rating</i> section.
Current De-Rated Power Rating	The kw rating after the De-Rate

#### Var

**NOTE:** The *-kvar Rating* is also derated by the *same De-Rate %* which is used to derate the *+kvar Rating*.

The screenshot shows a control panel titled 'VAr'. It contains four rows of data: 'De-Rate' is set to 92% with a slider; 'Current De-Rated VAr %' is 92%; 'Configured VAr Rating' is 375 kVAr; and 'Current De-Rated VAr Rating' is 345 kVAr.

Parameter	Description
De-Rate	Select with the mouse and move the cursor to override the De-Rate % to the desired level. 100% represents Full kvar Rating. Reducing the % reduces the generator's kvar capacity to limit the kvar produced when in Mains Parallel Mode, or when load sharing over the MSC.
Current De-Rated var %	The de-rated kvar power in percent (%).
Configured var Rating	The kvar Rating of the generator, as configured in the <i>Generator Rating</i> section.
Current De-Rated var Rating	The kvar rating after the De-Rate

### 3.8 ENGINE

This section displays the measurement of the *Engine* parameters. These measurements come from either the module's inputs or from the engine ECU/ECM. For further details on how to configure these items, refer to section entitled *Application* elsewhere within this document.

<b>Coolant Temperature</b> 81 °C, 178 °F	<b>Plant Battery</b> 13.2 V DC
<b>Oil Pressure</b> 5.16Bar, 74.8 PSI, 516 kPa	<b>Charge Alternator</b> 28.2 V DC
<b>Speed</b> 1499 RPM	<b>Hours Run</b> 1821:33
<b>Fuel Level</b> 73 %	<b>Number Of Starts</b> 578

#### 3.8.1 FUEL USE AND EFFICIENCY

This section displays the measurement of the *Fuel Use and Efficiency* parameters. These measurements come from either the module's inputs or from the engine ECU/ECM. For further details on how to configure these items, refer to section entitled *Fuel Use and Efficiency* under the *Engine* section elsewhere within this document.

<b>Fuel Consumption</b>		
Instantaneous 9.90 l/hr	Trip 10.26 l/hr	
<b>Fuel Use</b>		
Trip 1 litres		Accumulated 29978 litres
<b>Fuel Efficiency</b>		
Instantaneous 2.60 kWh/l	Trip 2.59 kWh/l	Accumulated 2.30 kWh/l
<b>Run Time Until Empty</b>		
25:13 hh:mm		

### 3.9 FLEXIBLE SENSORS

This section displays the status and instrumentation measured by the module's analogue inputs and the functions they are configured for. For further details on how to configure these items, refer to section entitled *Analogue Inputs* elsewhere within this document.

<p>Flexible Sensor A</p> <p>Not Used</p>
<p>Flexible Sensor B</p> <p>Not Used</p>
<p>Flexible Sensor C</p> <p>Flexible Sensor C 44 °C</p>
<p>Flexible Sensor D</p> <p>Configured As Digital Input</p>

### 3.10 CONFIGURABLE CAN INSTRUMENTATION

This section displays the module's readings of the configured *CAN Instrumentation*. This is only available if the module is configured for *Configurable CAN Instrumentation*, the *Enhanced Canbus* option is enabled, and the message is available over the relevant configured CAN bus. For further details on how to configure these items, refer to section entitled *Configurable CAN Instrumentation* in the *Edit Config* section elsewhere within this document.

Configurable CAN Instrumentation		
1	Engine Coolant Temp - ET1	21 °C
2	Engine Oil Pressure - EFL_P1	500 kPa
3	Engine Fuel Used - LFC	Bad Data
4	Engine Speed - EEC1	1500.000 RPM
5	Engine Hours - Hours	0.0 hr
6	Engine Fuel Pressure - EFL_P1	124 kPa
7	Engine Oil Temperature - ET1	32.14723 °C
8	Engine Coolant Pressure - EFL_P1	0.62 kPa
9	Engine Inlet Temp - IC1	Bad Data
10	Engine Coolant Level - EFL_P1	100 %

### 3.11 ALARMS

This section displays the alarms that are currently active on the module. For information in regards to alarm descriptions, refer to DSE publication: **057-254 DSE8610 MKII Operation Manual** which is found on the DSE website: [www.deepseaelectronics.com](http://www.deepseaelectronics.com).

For information in regards to alarm severity, refer to section entitled *Alarm Types* elsewhere within this document.

#### Alarms

**Shutdown Alarms**

- Emergency Stop
- Oil Pressure Sensor Open Circuit
- Temp Sender Open Circuit Alarm

**Electrical Trip Alarms**

**Warning Alarms**

Alarms that are active on the unit are grouped based on their type. For example, the *Emergency Stop* alarm appears in the *Shutdown Alarms* list because it has generated a *Shutdown* alarm type.

#### Reset Electrical Trip

**NOTE:** For further details on how this function is configured, refer to section entitled *Reset Electrical Trip* elsewhere within this document.

**Reset Electrical Trip**

Reset Count	Time Period
0	05:00

Parameter	Description
Reset Count	The number of times any electrical trips has been reset whilst the generator is running to enable it to go back on load. The counter goes to zero upon the generator stopping.
Time Period	The time interval for the <i>Reset Count</i> . If the <i>Reset Count</i> limit is reached within configured <i>Time Period</i> , no more resets can occur until the generator has stopped.

### 3.12 ENGINE ALARMS

The *Engine Alarms* page is subdivided into smaller sections. Select the required section with the mouse.

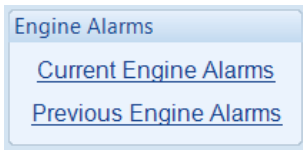

#### 3.12.1 CURRENT ENGINE ALARMS

This section displays the list of active *ECU Current DTCs* (Diagnostic Trouble Codes) which are being read from the engine's ECU. *ECU Current DTCs* are DM1 messages and are only read when the engine's ECU is awake (powered up). For information, refer to DSE publication: **057-004 Electronic Engines And DSE Wiring** which is found on the DSE website: [www.deepseaelectronics.com](http://www.deepseaelectronics.com).

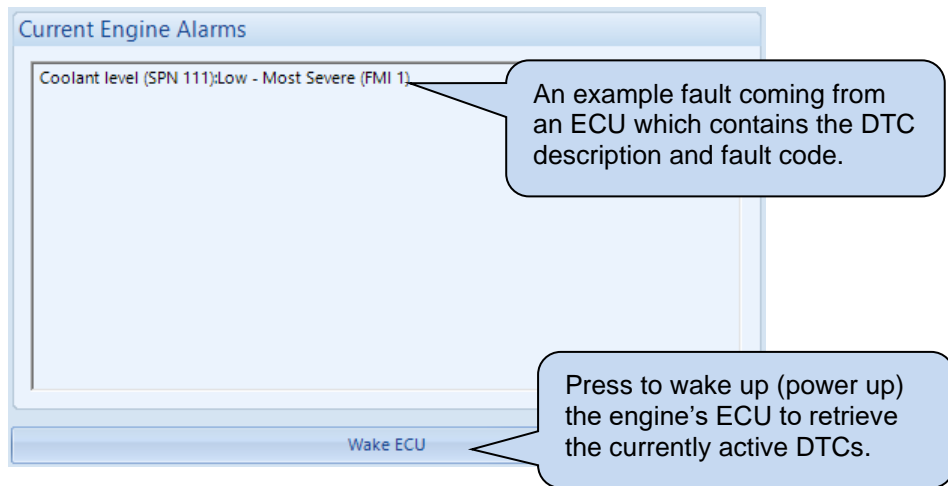

#### 3.12.2 PREVIOUS ENGINE ALARMS

This section displays the list of active *ECU Previous DTCs* (Diagnostic Trouble Codes) which are being read from the engine's ECU. *ECU Previous DTCs* are DM2 messages and are only read when the engine's ECU is awake (powered up). For information, refer to DSE publication: **057-004 Electronic Engines And DSE Wiring** which is found on the DSE website: [www.deepseaelectronics.com](http://www.deepseaelectronics.com).

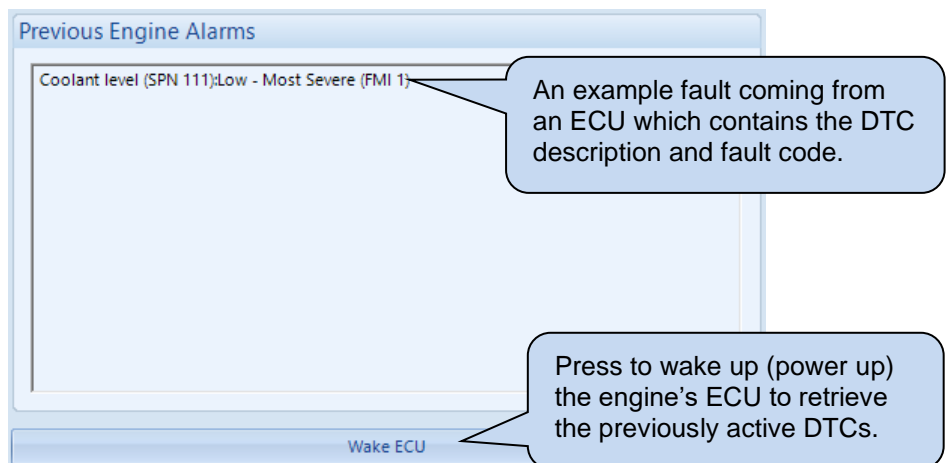

### 3.13 STATUS

This section displays the status information about the module.

<b>Supervisor State</b> Running On Load	<b>Software Version</b> Main version: 4.1.2 Bootloader: 3.0.23 Co-Processor: 1.2.3 Auxiliary: 2.0.22
<b>Engine/Generator State</b> Running	<b>Module ID</b> 671EC0713E
<b>Load Switching State</b> Generator On Load	<b>Mode</b> 
<b>Protections</b> Enabled	
<b>Heater Fitted</b> No Heater Fitted	

### 3.14 EVENT LOG

This section displays the events which are recorded with the module's event log along with the time, date and engine hours in which they occurred. For further details on how what events are recorded, refer to section entitled *Event Log* elsewhere within this document.

For information in regards to alarm descriptions, refer to DSE publication: **057-254 DSE8610 MKII Operation Manual** which is found on the DSE website: [www.deepseaelectronics.com](http://www.deepseaelectronics.com).

#	Date	Time	Hours Run	Event	Details
1	12/02/2019	11:00:26	1821:21	Start	Engine Started
2	12/02/2019	10:46:37	1821:21	Stop	Engine Stopped
3	12/02/2019	10:46:01	1821:21	Start	Engine Started
4	12/02/2019	10:45:56	1821:21	Warning	ECU Amber
5	12/02/2019	10:41:31	1821:21	Warning	MSC Failure
6	12/02/2019	10:38:08	1821:21	Stop	Engine Stopped
7	12/02/2019	10:37:08	1821:21	Start	Engine Started
8	12/02/2019	10:19:37	1821:21	Stop	Engine Stopped
9	12/02/2019	10:19:15	1821:21	Start	Engine Started
10	11/02/2019	16:40:25	1821:21	Stop	Engine Stopped
11	11/02/2019	16:31:28	1821:12	Start	Engine Started
12	11/02/2019	16:20:21	1821:12	Stop	Engine Stopped
13	11/02/2019	16:14:34	1821:06	Start	Engine Started
14	11/02/2019	15:49:13	1821:06	Stop	Engine Stopped
15	11/02/2019	15:43:30	1821:00	Start	Engine Started
16	11/02/2019	09:56:56	1821:00	Stop	Engine Stopped
17	11/02/2019	09:02:56	1820:06	Start	Engine Started
18	11/02/2019	08:53:26	1820:06	Warning	MSC Failure
19	08/02/2019	14:48:53	1820:06	Stop	Engine Stopped
20	08/02/2019	14:40:40	1819:57	Start	Engine Started
21	08/02/2019	14:26:48	1819:57	Stop	Engine Stopped
22	08/02/2019	13:03:46	1818:36	Start	Engine Started
23	08/02/2019	12:03:59	1818:36	Stop	Engine Stopped
24	08/02/2019	11:30:45	1818:03	Start	Engine Started
25	08/02/2019	11:29:54	1818:03	Stop	Engine Stopped
26	08/02/2019	11:27:29	1818:00	Start	Engine Started

Export to Excel
Export to CSV
Export to PDF
Print event log

Click to save the log to an Excel or csv file for use in an external spreadsheet

Click to save the log to a pdf (Adobe Acrobat) file.

Click to print the log

### 3.15 ENHANCED CANBUS

This section displays the measurement of the *Engine* parameters. These measurements come from the engine ECU/ECM. For further details on how to configure engine ECU/ECM, refer to section entitled *Application* elsewhere within this document.

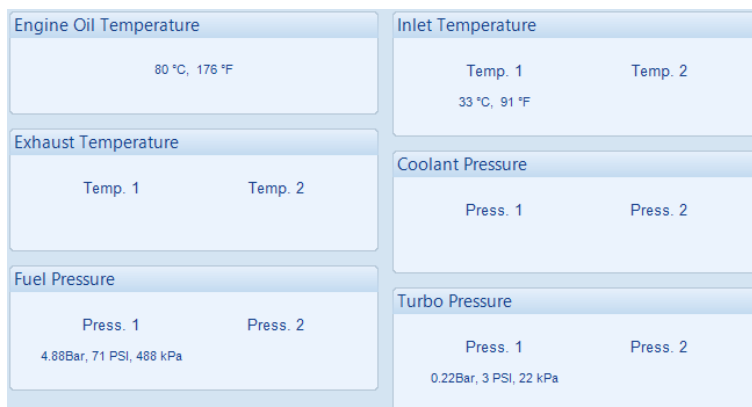

### 3.16 REMOTE CONTROL

This section displays and controls the status of the module's *Remote Control* functions. Any of the module's outputs, expansion outputs, LED indicators, expansion LEDs indicators or PLC Flag Tests are to be configured to *Remote Control 1 to 10*. They are provided to enable control using the SCADA section of the DSE Configuration Suite or by third party PLC or Building Management Systems (for example) using the MODBUS protocol. For further details on how to configure these items, refer to section entitled *Digital Outputs* elsewhere within this document.

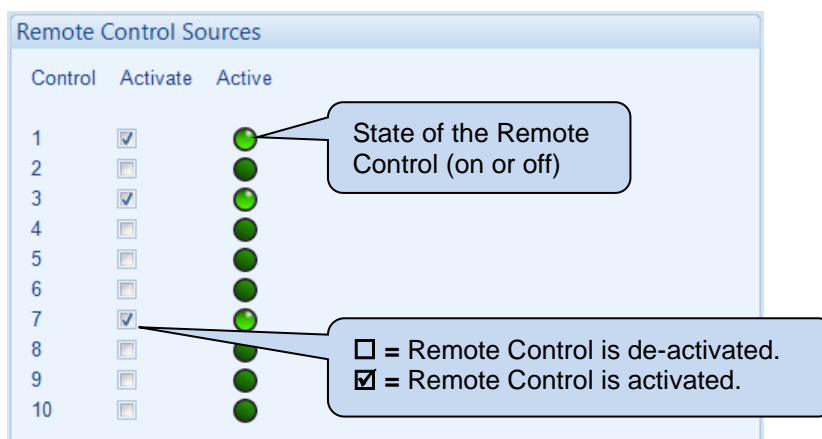

### 3.17 MAINTENANCE

The *Maintenance* section is subdivided into smaller sections. Select the required section with the mouse.



### 3.17.1 RECALIBRATE TRANSDUCERS

This section allows the analogue sensor inputs of the module to be calibrated to remove inaccuracies caused by the tolerance of the sensor devices. While the engine is running, the instruments are calibrated and reference needs to be made to a third party accurate sensing device to ensure accurate recalibration.

The screenshot displays a user interface for recalibrating transducers. It consists of five main sections:

- Analogue Input A:** Shows a slider with a green handle positioned at the left end, labeled "0 Bar". A callout box points to this label with the text: "The value for the sensor as displayed on the module's display".
- Analogue Input B:** Shows a slider with a green handle positioned in the middle, labeled "Not configured". A callout box points to the slider with the text: "Adjust the slider to alter the module's calibration for the sensor".
- Analogue Input C:** Shows a slider with a green handle positioned in the middle, labeled "Fault".
- Analogue Input D:** Shows a slider with a green handle positioned at the left end, labeled "20 %".
- Reset:** Contains a button labeled "Reset to Default". A callout box points to this button with the text: "Click to reset all the recalibration settings back to default."

### 3.17.2 EXPANSION CALIBRATION

This section allows the analogue sensor inputs of the DSE2130 and DSE2131 expansion modules to be calibrated to remove inaccuracies caused by the tolerance of the sensor devices. While the engine is running, the instruments are calibrated and reference needs to be made to a third party accurate sensing device to ensure accurate recalibration.

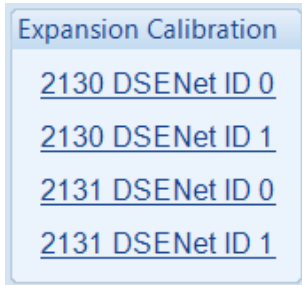

### 3.17.3 HOURS RUN AND NUMBER OF STARTS

This section allows the Hours Run and Number of Starts to be customised on the controller. Typically, this is used when fitting a new controller to an older engine so that the controller display matches the amount of work previously done by the system.

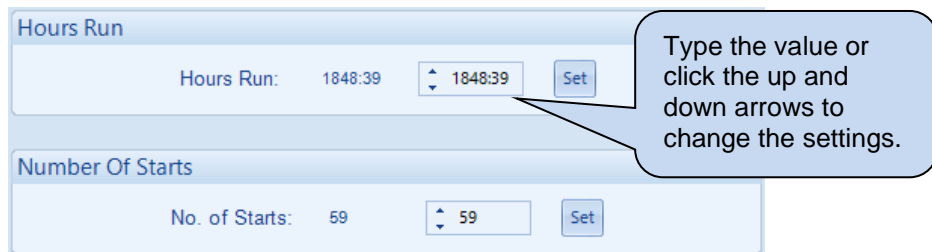

### 3.17.4 TIME

This section allows the date and time to be adjusted on the controller.

The screenshot displays a SCADA interface for time adjustment, divided into four sections:

- Module Date:** Shows the current date as 05/04/2019. A callout indicates: "Display of the module's current date and time".
- Module Time:** Shows the current time as 12:38:16. A callout indicates: "Type the new date / time or click the up and down arrows to change the settings".
- Set Date And Time:** Contains two dropdown menus for "Date" (05/04/2019) and "Time" (12:38:12), and a "Set" button. A callout points to the "Set" button: "Click Set to adjust the module to the selected date/time."
- Set To PC Time:** Shows "Date 05/04/2019" and "Time 13:38:00" with a "Set To PC Time" button. A callout points to the button: "Click Set to adjust the module to the date/time that the PC is set to."

### 3.17.5 ACCUMULATED INSTRUMENTATION

This section allows the generators accumulated instrumentation and the Fault Ride Through Events counter to be adjusted on the controller.

The screenshot displays a control interface for accumulated instrumentation, organized into five horizontal panels. Each panel contains a label, a current value, a numeric input field with up/down arrows, and a 'Set' button. The panels are: kWh (30.6 kWh), kVAh (38.2 kVAh), kVArh (22.7 kVArh), Fault Ride Through (19 Events), and a Reset panel with a 'Reset all values to zero' button. Callout boxes provide instructions: 'Display of the module's current value for the parameter.' points to the kWh value; 'Type the new value or click the up and down arrows to change the settings.' points to the kVAh input field; 'Click Set to adjust the module to the selected value.' points to the kWh Set button; and 'Click to reset all the accumulated instrumentation counters to zero.' points to the Reset button.

### 3.17.6 ACCUMULATED FUEL USE

This section allows the total fuel used value to be adjusted on the controller.

The screenshot displays two sections of the SCADA interface. The top section, titled 'Fuel Use', shows a label 'Fuel Use: 61 litres' followed by a numeric input field containing '61' and a 'Set' button. A callout box points to the input field and the up/down arrows, stating: 'Type the new value or click the up and down arrows to change the settings.' The bottom section, titled 'Reset', contains a button labeled 'Reset all values to zero'. A callout box points to this button, stating: 'Click to reset all the accumulated instrumentation counters to zero.'

### 3.17.7 MAINTENANCE ALARM RESET

This section allows the module's three maintenance alarms to be reset and when the alarm is due to activate.

The screenshot displays three stacked panels for maintenance alarm management:

- Oil Filter:** Shows 'Running Time Until Next Maintenance' as 500:00 and 'Date Of Next Maintenance' as 04/10/2019 22:38:13. A callout box states: 'The number of engine hours or date until the maintenance alarm activates.'
- Fuel Filter:** Shows 'Running Time Until Next Maintenance' as 1000:00 and 'Date Of Next Maintenance' as 04/10/2019 22:38:13. A callout box states: 'Reset the maintenance alarm based upon the module's configuration.'
- Air Filter:** Shows 'Running Time Until Next Maintenance' as 1000:00 and 'Date Of Next Maintenance' as 04/04/2020 08:14:13.

Each panel contains a 'Reset' button and the instruction: 'Press reset to schedule next maintenance, based upon module's maintenance configuration.'

### 3.17.8 ELECTRONIC ENGINE CONTROLS

This section allows settings within the engine's ECU to be altered when supported.

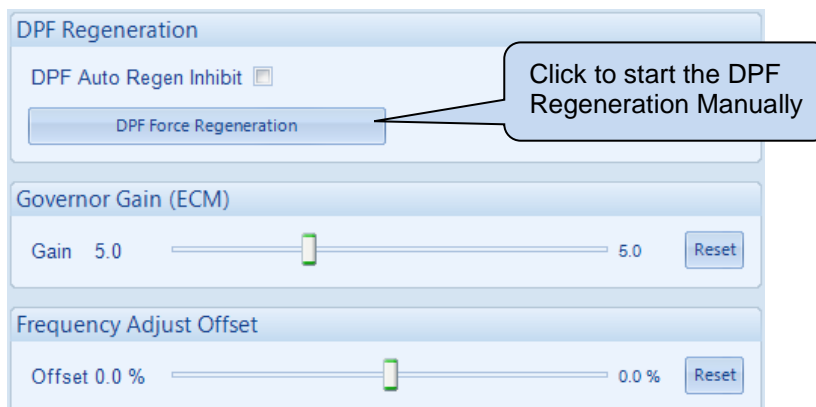

Parameter	Description
DPF Auto Regen Inhibit	<input type="checkbox"/> = The ECU's DPF Auto Regeneration happens automatically. <input checked="" type="checkbox"/> = The ECU's DPF Auto Regeneration is inhibited from activating.
Governor Gain (ECM)	The setting for the <i>Gain (P)</i> of the ECU/ECM's control loop over the engine speed.
Frequency Adjust Offset	A positive/negative offset that is applied to the entire ECU/ECM's droop setting as percentage its configured nominal speed.  An <i>Offset</i> of -1% with a nominal speed of 1500 RPM would result in the entire ECU's droop curve being offset by 15 RPM.

### 3.17.9 MODULE PIN

**⚠ CAUTION!: If the module PIN is lost or forgotten, it is no longer possible to access or make changes to the module!**

This section allows the user to configure a PIN (Personal Identification Number) within the module. This PIN must be entered to access the modules *Main Front Panel Configuration Editor* or, when writing a configuration / changing a value in SCADA using the DSE Configuration Suite PC Software.

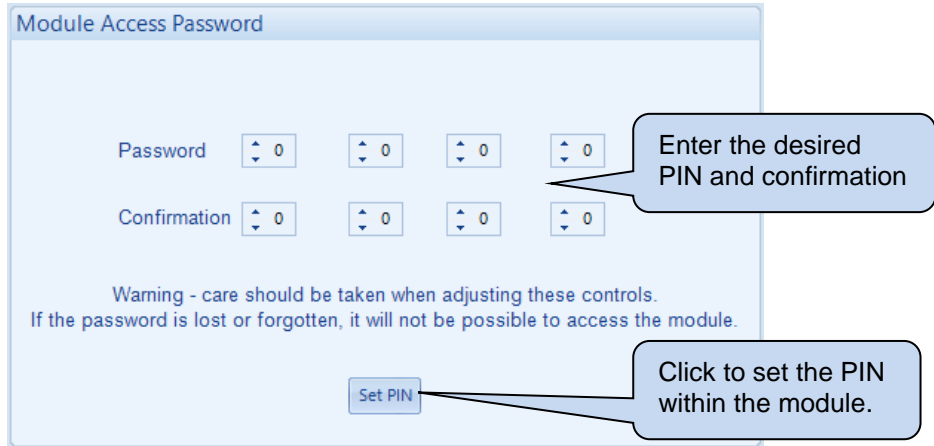

### 3.18 COMMUNICATIONS INFORMATION

This section displays the information about the configuration of the module's ethernet port. For further details on how to configure the module's ethernet port, refer to section entitled *Ethernet* elsewhere within this document.

<b>IP address</b> 192 . 168 . 1 . 100	<b>MAC Address</b> E8 : A4 : C1 : 2 : 8D : 7
<b>Subnet Mask</b> 255 . 255 . 255 . 0	<b>DNS</b> 8 . 8 . 8 . 8
<b>Host</b> DSE Host	<b>MODBUS Preferred IP Address</b> 192 . 168 . 1 . 99
<b>Domain</b> DSE Module	<b>MODBUS Connection Port</b> 502
<b>Gateway</b> 192 . 168 . 1 . 1	<b>DHCP</b> Off
	<b>TCP Vendor</b> DSE Vender

### 3.19 DATA LOG

This section displays and temporarily records the instruments configured within the module's *Data Logging* facility to the PC. The data which is temporarily recorded is only for the duration in which the *Data Log* section is viewed. For further details on how to configure these items, refer to section entitled *Data Logging* elsewhere within this document.

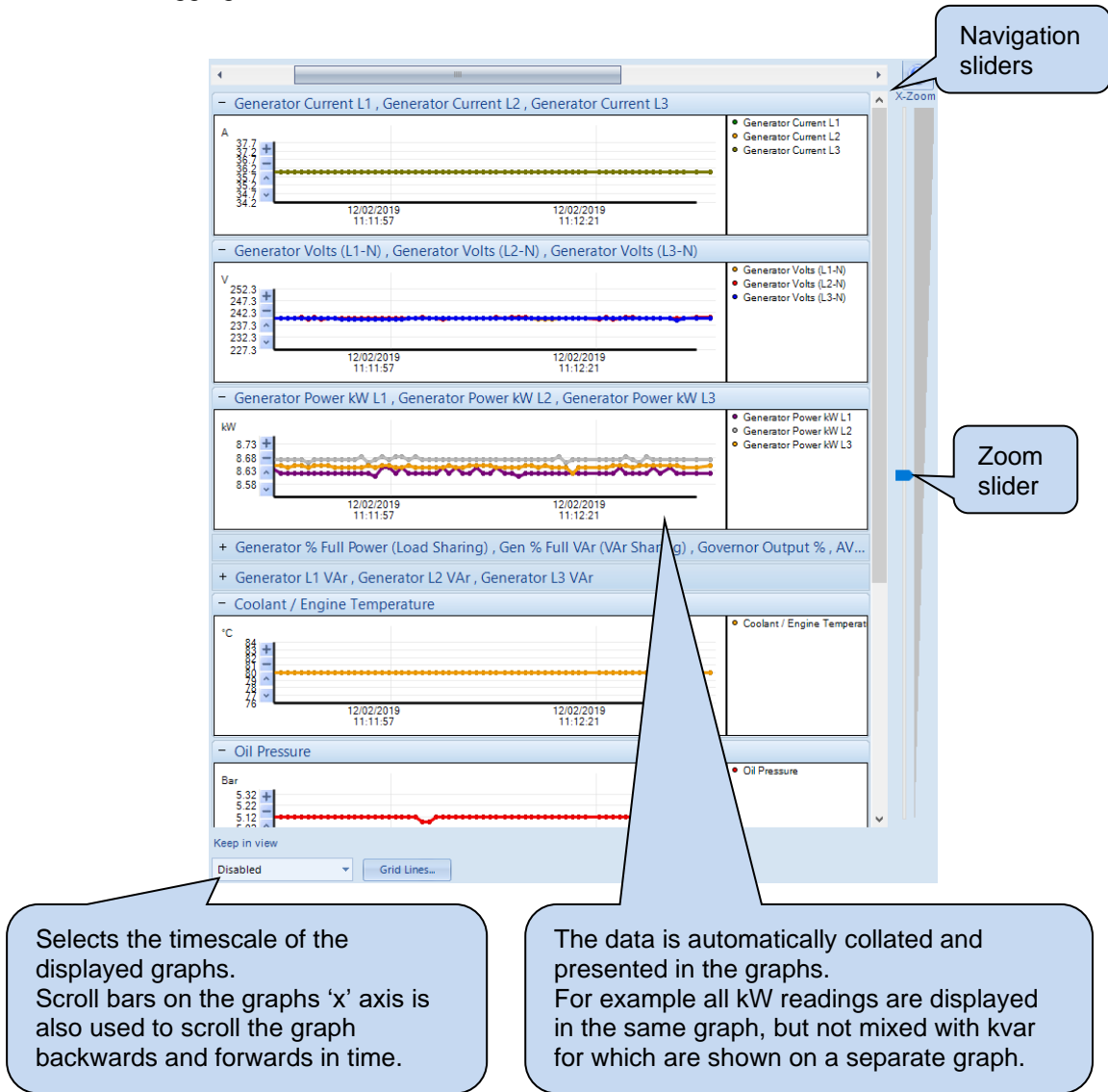

### 3.19.1 DATA LOG STATUS

This section displays the information module's *Data Logging* function. For further details on how to configure the module's Data Logging function, refer to section entitled *Data Logging* elsewhere within this document.

<b>Internal Memory Capacity</b> 2048 kB	<b>Data Logging Status</b> Logging
<b>Remaining Data Log Memory</b> Space remaining in Internal memory: 2032 kB	<b>Data Log Mode</b> Keep New
<b>Remaining Data Log Time</b> 7h 30m	<b>USB Drive Status</b> Not Fitted
<b>Total Log Pages Available</b> 128	<b>Data Log Destination</b> Internal
<b>Current Page Usage</b> 4.473 kB	

### 3.20 AVR

The AVR section is subdivided into smaller sections.  
Select the required section with the mouse.

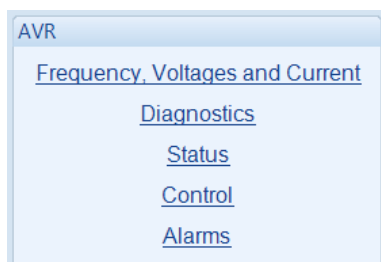

#### 3.20.1 FREQUENCY, VOLTAGES AND CURRENT

**NOTE:** The *Feedback Voltages* might not indicate the true *Generator Voltage* values. The *Feedback Voltage* instruments reading depend on the CAN AVR device being used and the way it is connected to the AC alternator. The DSEA108 supports only single phase voltage sensing connected as *Ph-N* or *Ph-Ph*. The DSEA109 supports single phase or three phase voltage sensing. For further details, refer to DSE Publication: *057-281 DSEA108 Operator Manual* or *057-295 DSEA109 Operator Manual* available on our website: [www.deepseaelectronics.com](http://www.deepseaelectronics.com)

Frequency		
50.1 Hz		
Feedback Voltage		
L1 - L2 209.4 V	L2 - L3 209.3 V	L3 - L1 209.2 V
Average 209.3 V		
Droop Current		
0.00 A		
Excitation Voltage		
12.9 V		
Auxiliary Voltage		
173.7 V		

### 3.20.2 DIAGNOSTICS

<b>External Control</b>		
Potentiometer +++	Voltage 0.02 V	
<b>Set Points</b>		
Voltage 120.0 V	Droop 3.0 %	UFRO Knee 42.7 Hz
Proportional 80.6	Integral 9.7	Derivative 50.0
<b>Excitation Output</b>		
Off Load Duty Cycle 8.0 %	Maximum Duty Cycle 100.0 %	
<b>Soft Start</b>		
Ramp Start Point (% of set point) 27.0 %	Ramp Rate (%/s) 30.0 %	

### 3.20.3 STATUS

<b>Status</b>	
<b>Software Version</b>	
2.0.2	
<b>Configuration</b>	
Active Configuration 0	Active Stability Configuration 1

### 3.20.4 CONTROL

**NOTE:** The *Active Configuration Selection* and the *Active Stability Configuration Selection* SCADA settings are only adjustable if they are enabled within the DSE CAN AVR's configuration. For further details, refer to DSE Publication: *057-283 DSEA108 Software Manual* or *057-294 DSEA109 Software Manual* available on our website: [www.deepseaelectronics.com](http://www.deepseaelectronics.com)

Set Points			
Droop	3.0 %		3.0 %
Proportional	80.6		80.6
Integral	9.7		9.7
Derivative	50.0		50.0

Excitation Output			
Off Load Duty Cycle	8.0 %		8.0 %
Maximum Duty Cycle	100.0 %		100.0 %

Soft Start			
Ramp Start Point (% of set point)	27.0 %		27.0 %
Ramp Rate (%/s)	30.0 %		30.0 %

Configuration			
Active Configuration	0		0
Active Stability Configuration	1		1

### 3.20.5 AVR ALARMS

AVR Alarms
Start-up failed trip

### 3.21 PLC

**NOTE:** This section is only available on the pre-version 5 software of the module.  
 For further details and instructions on how to utilise the *PLC*, refer to DSE publication: *057-175 PLC Programming Guide for DSE Controllers*, which is found on the DSE website: [www.deepseaelectronics.com](http://www.deepseaelectronics.com).

**NOTE:** On module software versions 6.1 and later, the *Connect SCADA* is available within the *PLC Editor* accessed from the main configuration's PLC section.  
 For further details and instructions on the *PLC Editor*, refer to DSE Publication: *057-314 Advanced PLC Software Manual* which is found on our website: [www.deepseaelectronics.com](http://www.deepseaelectronics.com)

The *PLC* section is subdivided into smaller sections.  
 Select the required section with the mouse.

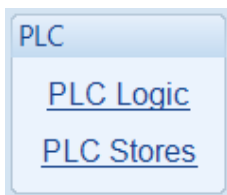

#### 3.21.1 PLC LOGIC

This section displays the real-time status of the *PLC Logic* configured within the module. This section is useful for assisting with fault finding issues relating to or caused by the *PLC Logic*.

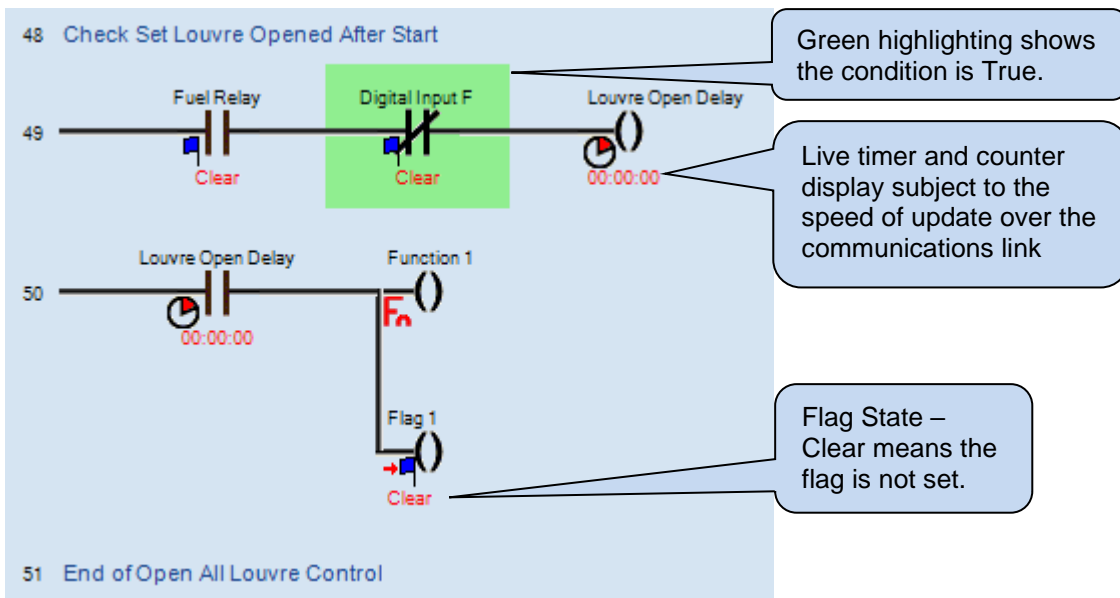

### 3.21.2 PLC STORES

The *PLC Stores* section is subdivided into smaller sections. Select the required section with the mouse.



The selected section displays the value currently set for each *Store* and provides the user with the ability to change that value. *Stores* are used within the module's PLC to affect mathematical equations or change set points within the created PLC functions.

PLC Stores

Store 1	0		
Store 2	0	▲ 0 ▼	Set
Store 3	0	▲ 0 ▼	Set
Store 4	0	▲ 0 ▼	Set
Store 5	0	▲ 0 ▼	Set
Store 6	0	▲ 0 ▼	Set
Store 7	0	▲ 0 ▼	Set
Store 8	0	▲ 0 ▼	Set
Store 9	0	▲ 0 ▼	Set
Store 10	0	▲ 0 ▼	Set
Store 11	0	▲ 0 ▼	Set
Store 12	0	▲ 0 ▼	Set
Store 13	0	▲ 0 ▼	Set
Store 14	0	▲ 0 ▼	Set
Store 15	0	▲ 0 ▼	Set
Store 16	0	▲ 0 ▼	Set
Store 17	0	▲ 0 ▼	Set
Store 18	0	▲ 0 ▼	Set
Store 19	0	▲ 0 ▼	Set
Store 20	0	▲ 0 ▼	Set

Display of the module's current value for the parameter.

Type the new value or click the up and down arrows to change the settings.

Click Set to adjust the module to the selected value.

### 3.22 EXPANSION

The *Expansion* section is subdivided into smaller sections. Select the required section with the mouse.

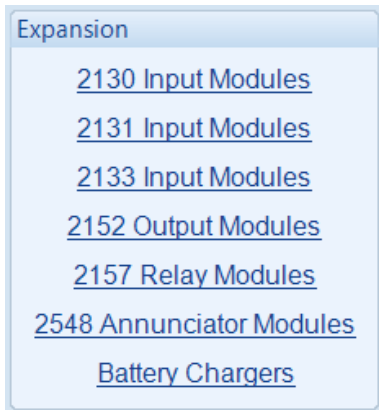

The selected section displays the status of the expansion module's inputs/outputs/LEDs etc and the functions they are configured for. For further details on how to configure these items, refer to section entitled *Expansion* in the *Edit Config* section elsewhere within this document. An example status of a DSE2157 Output Expansion is shown below.

Communications

Communications OK ● State of communication to the expansion module

---

Relay Outputs (Normally Open)

	Active	Open / Closed
A Fuel Pump Control	●	⚡
B Close Gen Output	●	⚡
C Not Used	●	⚡
D Not Used	●	⚡

State of the output (open or closed)

---

Relay Outputs (Changeover)

	Active	Open / Closed
E PLC Output Flag 1	●	⚡
F PLC Output Flag 2	●	⚡
G PLC Output Flag 3	●	⚡
H Not Used	●	⚡

Shows if the output channel is active or not. This output is open and is active. The output is configured to be *PLC Output Flag 3 De-Energise*.

## 4 ALARM TYPES

The protection included with the DSE control modules provides increasing levels of notification, depending upon the severity of the situation:

Alarm Type	Description
Indication	No audible alarm or common warning signal occurs. <i>Indication</i> alarms are only used to illuminate indicators, activate outputs or checked by the module's internal PLC.
Warning	Audible alarm and common alarm signal is generated. The set continues to run. <i>Warning alarms</i> are used to draw the operator's attention to a minor issue or to a problem that may escalate to an Electrical Trip or Shutdown Alarm if left untreated.
Electrical Trip	Audible alarm and common alarm signal is generated. The set is taken off load and the cooling timer begins, after which the set is stopped. <i>Electrical Trip alarms</i> are series issues that require the set to be taken off load. As the name implies, this is often electrical faults that occur 'after' the load switch. The set is allowed to cool before stopping.
Shutdown	Audible alarm and common alarm signal is generated. The set is taken off load and immediately stopped. <i>Shutdown alarms</i> are serious issues that demand immediate stopping of the generator. For instance Emergency Stop or Overspeed alarms require immediate shutdown.

## 5 ALARM ARMING

The protections on the DSE module are active during their configured *Alarm Arming* setting. The table below shows the timing segment for the different *Alarm Arming* options with regards to the generator status.

Timing Segment	Stopped	Start Delay	ECU Wake Up Delay	Preheat	Cranking	Safety on Delay	Smoke Limiting	Smoke Limiting Off	Warming Up	Gen Available	Gen On Load	Cooling	Cooling in Idle
Never													
Always													
When Stationary													
From Starting													
Overfrequency / Overspeed Overshoot													
From Safety On													
From Breaker Closed													
From Mains Parallel													

## 5.1 NEVER

The protection is never active on the controller. This is used to disable the protection.

## 5.2 ALWAYS

The protection is always active on the controller. This is used to constantly monitor statuses such as a fuel level switch irrespective of the engine running state.

## 5.3 WHEN STATIONARY

The protection is active from the moment the engine stops until the beginning of engine cranking.

## 5.4 FROM STARTING

The protection is active from the beginning of engine cranking, until the engine stops.

## 5.5 OVERSHOOT

Active during the *Safety Delay* timer, this allows for a temporary raise of the overspeed/overfrequency trip points during start-up.

Protection Level	Over Frequency Trip Level	Over Speed Trip Level
Immediate Shutdown	Over Frequency + Overshoot %	Over Speed + Overshoot %
Delayed Shutdown (Overspeed Overshoot Delay)	Over Frequency	Over Speed

### Example

57 Hz *Over Frequency* setting, 10% *Overspeed Overshoot*

During *Safety Delay* a generator frequency above  $(57 \text{ Hz} \times 1.1) = 62.7 \text{ Hz}$  results in an immediate shutdown without delay.

After *Safety delay*, a generator frequency above 57 Hz for the period of the *Generator Transient Delay* results in a shutdown

## **5.6 FROM SAFETY ON**

The protection is active when the set is running at nominal speed, until the engine stops.

## **5.7 FROM BREAKER CLOSED**

The protection is active when the set is running with its switchgear closed .

## **5.8 FROM MAINS PARALLEL**

The protection is active when the set is running with its switchgear closed and a digital input configured for *Mains Parallel Mode* is active.

*Page is Left Intentionally Blank*

*Page is Left Intentionally Blank*