



DEEP SEA ELECTRONICS
DSE4510 MKII & DSE4520 MKII
Configuration Suite PC Software Manual

Document Number: 057-258

Author: Ashley Senior





Deep Sea Electronics Ltd.

Highfield House
Hunmanby
North Yorkshire
YO14 0PH
England

Sales Tel: +44 (0) 1723 890099

E-mail: sales@deepseaelectronics.com

Website: www.deepseaelectronics.com

DSE4510 MKII & DSE4520 MKII Configuration Suite PC Software Manual

© Deep Sea Electronics Ltd.

All rights reserved. No part of this publication may be reproduced in any material form (including photocopying or storing in any medium by electronic means or other) without the written permission of the copyright holder except in accordance with the provisions of the Copyright, Designs and Patents Act 1988.

Applications for the copyright holder's written permission to reproduce any part of this publication must be addressed to Deep Sea Electronics Ltd. at the address above.

The DSE logo and the names DSEGenset®, DSEATS®, DSEPower® and DSEControl® are UK registered trademarks of Deep Sea Electronics Ltd.

Any reference to trademarked product names used within this publication is owned by their respective companies.

Deep Sea Electronics Ltd. reserves the right to change the contents of this document without prior notice.

Amendments Since Last Publication

Issue No.	Comments
1	Initial release
2	Updated for version 2 of the DSE45xx MKII.
3	Updated for version 3 of the DSE45xx MKII. 0V-10V Voltage sensor support added to the Analogue input A for the Oil Pressure.
4	Updated for version 4 of the DSE45xx MKII.
5	Updated for version 5 of the DSE45xx MKII. 4 mA to 20mA sensor support added to the Analogue input A.
6	Add custom icons for user configured inputs and wait to start.
7	Updated style of document. Added Transducer Supply, Text Icons and High Coolant Temperature Pre-Alarm.

Typeface: The typeface used in this document is *Arial*. Care must be taken not to mistake the upper case letter I with the numeral 1. The numeral 1 has a top serif to avoid this confusion.

TABLE OF CONTENTS

SECTION	PAGE
1 INTRODUCTION.....	5
1.1 CLARIFICATION OF NOTATION.....	6
1.2 GLOSSARY OF TERMS	6
1.3 BIBLIOGRAPHY	8
1.3.1 INSTALLATION INSTRUCTIONS	8
1.3.2 MANUALS.....	8
1.3.3 TRAINING GUIDES.....	8
1.3.4 THIRD PARTY DOCUMENTS	9
1.4 INSTALLATION AND USING THE DSE CONFIGURATION SUITE SOFTWARE	9
2 EDITING THE CONFIGURATION	10
2.1 SCREEN LAYOUT	10
2.2 MODULE.....	11
2.3 APPLICATION	15
2.4 INPUTS.....	16
2.4.1 ANALOGUE INPUT CONFIGURATION	16
2.4.2 ANALOGUE INPUTS.....	18
2.4.2.1 CREATING / EDITING THE SENSOR CURVE	20
2.4.3 DIGITAL INPUTS.....	22
2.4.3.1 DIGITAL INPUTS.....	22
2.4.3.1.1 CUSTOM ICON FOR DIGITAL INPUTS	23
2.4.3.2 ANALOGUE INPUTS.....	24
2.4.3.3 INPUT FUNCTIONS	25
2.5 OUTPUTS.....	28
2.5.1 OUTPUT SOURCES	28
2.6 TIMERS.....	34
2.6.1 START TIMERS	34
2.6.2 LOAD / STOPPING TIMERS	36
2.6.3 MODULE TIMERS.....	38
2.7 GENERATOR	39
2.7.1 GENERATOR OPTIONS	39
2.7.2 GENERATOR VOLTAGE	40
2.7.3 GENERATOR FREQUENCY.....	42
2.7.4 GENERATOR CURRENT.....	44
2.8 MAINS	46
2.8.1 MAINS OPTIONS	46
2.8.2 MAINS ALARMS	47
2.9 ENGINE	48
2.9.1 ENGINE PROTECTION.....	48
2.9.2 OIL PRESSURE	50
2.9.3 ENGINE COOLANT.....	51
2.9.3.1 COOLANT TEMPERATURE ALARMS.....	51
2.9.3.2 COOLANT TEMPERATURE CONTROL.....	53
2.9.3.3 COOLANT LEVEL ALARMS.....	54
2.9.4 FUEL OPTIONS	56
2.9.4.1 FUEL LEVEL	57
2.9.4.2 FUEL USAGE ALARM.....	61
2.9.5 ENGINE OPTIONS.....	62
2.9.6 ECU (ECM) OPTIONS.....	65
2.9.7 ECU (ECM) ALARMS	67
2.9.7.1 ECU (ECM) DATA FAIL.....	67
2.9.7.2 DM1 SIGNALS	68
2.9.7.3 OTHER SPECIFIC SIGNALS.....	70
2.9.8 GAS ENGINE OPTIONS.....	73
2.9.9 CRANK DISCONNECT.....	74
2.9.10 SPEED SETTINGS.....	75

2.9.11	PLANT BATTERY.....	76
2.10	SCHEDULER.....	78
2.11	MAINTENANCE ALARM.....	79
2.12	ALTERNATIVE CONFIGURATIONS.....	80
2.12.1	ALTERNATIVE CONFIGURATION OPTIONS.....	80
2.12.2	ALTERNATIVE CONFIGURATION 1 TO 3.....	81
2.12.2.1	CONFIGURATION OPTIONS.....	81
2.12.2.2	GENERATOR / MAINS / ENGINE.....	81
2.13	ADVANCED.....	82
2.13.1	CONFIGURABLE CAN INSTRUMENTATION.....	82
2.13.2	RECEIVED INSTRUMENTATION.....	82
2.13.2.1	DETAILS.....	83
2.13.3	TRANSMITTED INSTRUMENTATION.....	85
2.13.3.1	DETAILS.....	85
2.13.4	CONFIGURABLE CAN INSTRUMENTATION EXPORT/IMPORT.....	87
3	SCADA.....	88
3.1	MIMIC.....	89
3.2	DIGITAL INPUTS.....	90
3.3	DIGITAL OUTPUTS.....	90
3.4	MAINS.....	91
3.5	GENERATOR.....	92
3.6	POWER.....	93
3.7	ENGINE.....	94
3.8	FLEXIBLE SENSOR.....	95
3.9	CONFIGURABLE CAN INSTRUMENTATION.....	95
3.10	ALARMS.....	96
3.11	STATUS.....	97
3.12	EVENT LOG.....	98
3.13	ENHANCED CANBUS.....	99
3.14	MAINTENANCE.....	100
3.14.1	MAINTENANCE ALARM RESET.....	100
3.14.2	HOURS RUN AND NUMBER OF STARTS.....	101
3.14.3	DATE AND TIME.....	101
3.14.4	ACCUMULATED INSTRUMENTATION.....	102
3.14.5	DPF REGENERATION.....	102
3.14.6	MODULE PIN.....	103
3.14.7	LCD CONTRAST.....	103
4	ALARM TYPES.....	104
5	ALARM ARMING.....	105
5.1	NEVER.....	106
5.2	ALWAYS.....	106
5.3	WHEN STATIONARY.....	106
5.4	FROM STARTING.....	106
5.5	OVERSHOOT.....	106
5.6	FROM SAFETY ON.....	106

1 INTRODUCTION

This document details the use of the *DSE Configuration Suite PC Software* with the DSE4510 MKII and DSE4520 MKII modules, which are part of the DSEGenset® range of products.

The manual forms part of the product and should be kept for the entire life of the product. If the product is passed or supplied to another party, ensure that this document is passed to them for reference purposes.

This is not a *controlled document*. DSE do not automatically inform on updates. Any future updates of this document are included on the DSE website at www.deepseaelectronics.com



The *DSE Configuration Suite PC Software* allows the DSE45xx MKII modules to be connected to a PC via USB A to USB B cable (USB printer cable). Once connected, the software allows easy, controlled access to various operating parameters within the module which can then be viewed and edited as required.

The *DSE Configuration Suite PC Software* must only be used by competent, qualified personnel, as changes to the operation of the module may have safety implications on the panel / generating set to which it is fitted. Access to critical operational sequences and settings for use by qualified engineers, may be barred by a security code set by the generator provider.



The information contained in this manual must be read in conjunction with the information contained in the appropriate module documentation. This manual only details which settings are available and how they may be used. Separate manuals deal with the operation of the individual module and its ancillaries, refer to section entitled *Bibliography* elsewhere in this document for further information.

1.1 CLARIFICATION OF NOTATION

Clarification of notation used within this publication.

	NOTE:	Highlights an essential element of a procedure to ensure correctness.
	CAUTION!	Indicates a procedure or practice, which, if not strictly observed, could result in damage or destruction of equipment.
	WARNING!	Indicates a procedure or practice, which could result in injury to personnel or loss of life if not followed correctly.

1.2 GLOSSARY OF TERMS

Term	Description
DSE4xxx MKII	All modules in the DSE4xxx MKII range.
DSE4500 MKII, DSE45xx MKII	All modules in the DSE45xx MKII range.
DSE4510 MKIII 	DSE4510 MKII module/controller
DSE4520 MKIII 	DSE4520 MKII module/controller
CAN	Controller Area Network Vehicle standard to allow digital devices to communicate to one another.
CT	Current Transformer An electrical device that takes a large AC current and scales it down by a fixed ratio to a smaller current.
DEF	Diesel Exhaust Fluid (AdBlue) A liquid used as a consumable in the SCR process to lower nitric oxide and nitrogen dioxide concentration in engine exhaust emissions.
DM1	Diagnostic Message 1 A DTC that is currently active on the engine ECU.
DM2	Diagnostic Message 2 A DTC that was previously active on the engine ECU and has been stored in the ECU's internal memory.
DPF	Diesel Particulate Filter A filter fitted to the exhaust of an engine to remove diesel particulate matter or soot from the exhaust gas.
DPTC	Diesel Particulate Temperature Controlled Filter A filter fitted to the exhaust of an engine to remove diesel particulate matter or soot from the exhaust gas which is temperature controlled.
DTC	Diagnostic Trouble Code The name for the entire fault code sent by an engine ECU.
ECU/ECM	Engine Control Unit/Management An electronic device that monitors engine parameters and regulates the fuelling.
FMI	Failure Mode Indicator A part of DTC that indicates the type of failure, e.g. high, low, open circuit etc.

Continued over page...

Introduction

Term	Description
Fuel Tank Bund	An external tank used to collect fuel that may leak or overflow from the fuel tank. This tank may also be integral to the main fuel tank. A level switch is usually located within the Bund to indicate the presence of the leak or overflow condition. May be called Retention Tank in some locales.
HEST	High Exhaust System Temperature Initiates when DPF filter is full in conjunction with an extra fuel injector in the exhaust system to burn off accumulated diesel particulate matter or soot.
HMI	Human Machine Interface A device that provides a control and visualisation interface between a human and a process or machine.
IEEE	Institute of Electrical and Electronics Engineers
LED	Light Emitting Diode
OC	Occurrence Count A part of DTC that indicates the number of times that failure has occurred.
PGN	Parameter Group Number A CANbus address for a set of parameters that relate to the same topic and share the same transmission rate.
SCADA	Supervisory Control And Data Acquisition A system that operates with coded signals over communication channels to provide control and monitoring of remote equipment
SCR	Selective Catalytic Reduction A process that uses DEF with the aid of a catalyst to convert nitric oxide and nitrogen dioxide into nitrogen and water to reduce engine exhaust emission.
SPN	Suspect Parameter Number A part of DTC that indicates what the failure is, e.g. oil pressure, coolant temperature, turbo pressure etc.

1.3 BIBLIOGRAPHY

This document refers to, and is referred by the following DSE publications which are obtained from the DSE website: www.deepseaelectronics.com or by contacting DSE technical support: support@deepseaelectronics.com.

1.3.1 INSTALLATION INSTRUCTIONS

Installation instructions are supplied with the product in the box and are intended as a 'quick start' guide only.

DSE Part	Description
053-190	DSE4510 MKII & DSE4520 MKII Installation Instructions

1.3.2 MANUALS

Product manuals are obtained from the DSE website: www.deepseaelectronics.com or by contacting DSE technical support: support@deepseaelectronics.com.

DSE Part	Description
057-151	DSE Configuration Suite PC Software Installation & Operation Manual
057-004	Electronic Engines and DSE Wiring
057-260	DSE4510 MKII & DSE4520 MKII Operator Manual

1.3.3 TRAINING GUIDES

Training guides are provided as 'hand-out' sheets on specific subjects during training sessions and contain specific information regarding to that subject.

DSE Part	Description
056-005	Using CTs With DSE Products
056-006	Introduction to Comms
056-010	Over Current Protection
056-022	Switchgear Control
056-023	Adding New CAN Files
056-026	kVA, kW, kvar and Power Factor
056-029	Smoke Limiting
056-030	Module PIN Codes
056-051	Sending DSEGencomm Control Keys
056-055	Alternate Configurations
056-069	Firmware Update
056-076	Reading DSEGencomm Alarms
056-079	Reading DSEGencomm Status
056-080	MODBUS
056-081	Screen Heaters
056-082	Override Gencomm PLC Example
056-091	Equipotential Earth Bonding
056-092	Best Practices for Wiring Restive Sensors
056-095	Remote Start Input Functions
056-097	USB Earth Loops and Isolation
056-099	Digital Output to Digital Input Connection

1.3.4 THIRD PARTY DOCUMENTS

The following third party documents are also referred to:

Reference	Description
ISBN 1-55937-879-4	IEEE Std C37.2-1996 IEEE Standard Electrical Power System Device Function Numbers and Contact Designations. Institute of Electrical and Electronics Engineers Inc
ISBN 0-7506-1147-2	Diesel generator handbook. L.L.J. Mahon
ISBN 0-9625949-3-8	On-Site Power Generation. EGSA Education Committee.

1.4 INSTALLATION AND USING THE DSE CONFIGURATION SUITE SOFTWARE

For information in regards to installing and using the *DSE Configuration Suite PC Software*, refer to DSE publication: **057-151 DSE Configuration Suite PC Software Installation & Operation Manual** found on the DSE's website: www.deepseaelectronics.com

2 EDITING THE CONFIGURATION

This menu allows module configuration, to change the function of Inputs, Outputs and LED's, system timers and level settings to suit a particular application.

2.1 SCREEN LAYOUT

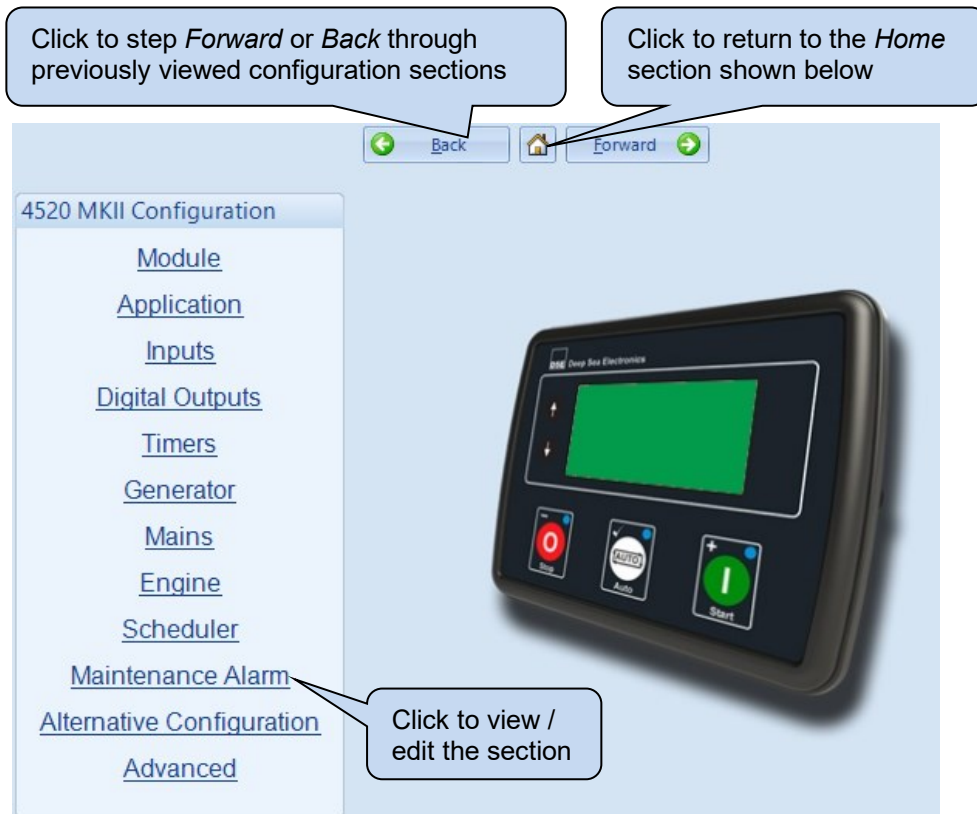
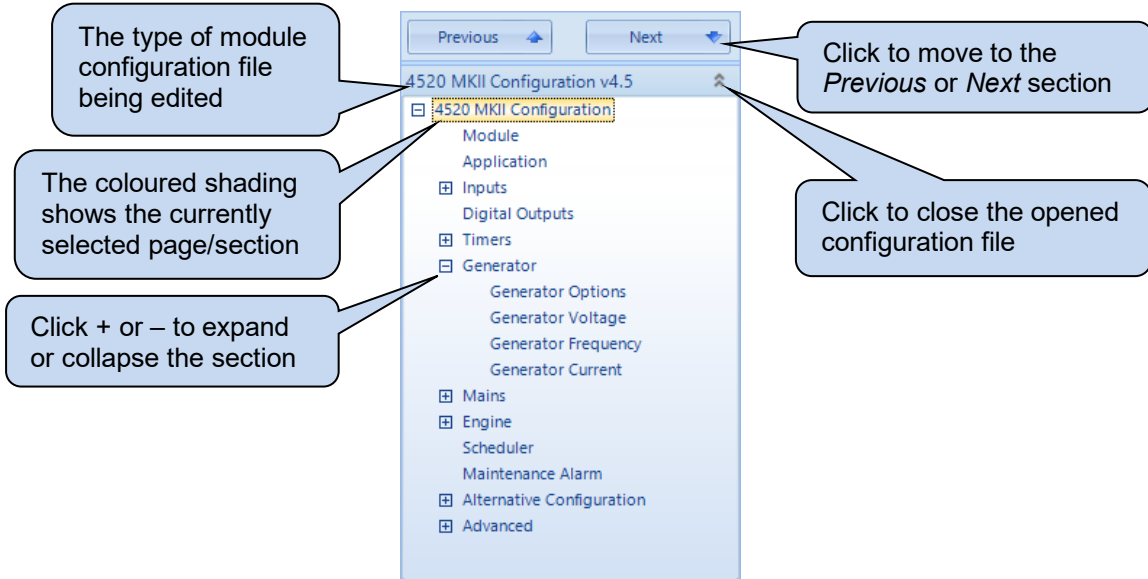

2.2 MODULE

Module Type

Parameter	Description
Module Type (DSE4520 MKII only)	Select the type of the module: Auto Start: Converts the DSE4520 MKII into a DSE4510 MKII. This allows the module to start in manual mode, and on activation of remote start signal when in auto mode. AMF: Allows the module to start in manual mode, and on activation of remote start signal or mains failure detection when in auto mode.

Module Options

Parameter	Description
Lamp Test At Power Up	<input type="checkbox"/> = Feature disabled <input checked="" type="checkbox"/> = All the LEDs on the module's fascia illuminate when the DC power is applied as a 'lamp test' feature.
Protected Start Mode	<input type="checkbox"/> = Pressing the Start button on the module initiates the starting sequence <input checked="" type="checkbox"/> = The Start button needs to be pressed twice to confirm a manual start request. When the Start button is pressed once the module waits for 30 seconds for the next press to start the generator in Manual mode, if the Start button is not pressed a second time within the next 30 seconds, the mode changes to Stop mode for safety.
Event Log in Hours Run	<input type="checkbox"/> = Recorded events in the module's event log include the date/time stamp <input checked="" type="checkbox"/> = The engine run hours is added to the recorded event in the event log
Display SPN Strings	<input type="checkbox"/> = The module displays CAN messages in manufacturer numerical code. <input checked="" type="checkbox"/> = The module displays CAN messages in ENGLISH text alongside the manufacturer numerical code.

Parameters are continued overleaf...

Parameter	Description
Enable Fast Loading	<p> NOTE: Enabling Fast Loading is only recommended where steps have been taken to ensure rapid start up of the engine is possible. (For example when fitted with engine heaters, electronic governors etc.)</p> <p><input type="checkbox"/> = Normal Operation, the safety on timer is observed in full. This feature is useful if the module is to be used with some small engines where premature termination of the delay timer leads to overspeed alarms on start up.</p> <p><input checked="" type="checkbox"/> = The module terminates the safety on timer once all monitored parameters have reached their normal settings. This feature is useful if the module is to be used as a standby controller as it allows the generator to start and go on load in the shortest possible time.</p>
Maintenance PIN Protected Enable	<p><input type="checkbox"/> = PIN is not required to reset maintenance alarms through the front panel.</p> <p><input checked="" type="checkbox"/> = Maintenance alarm reset through the front panel is PIN protected.</p>
Enable Cooldown in Stop Mode	<p><input type="checkbox"/> = Normal operation. Pressing the Stop button instantly opens the load switch and stops the generator.</p> <p><input checked="" type="checkbox"/> = Alternative operation. Pressing the Stop button instantly opens the load switch and puts the generator into a cooling run. Pressing the Stop button again instantly stops the generator.</p>
Power Up in Mode	<p>Select the mode that the module enters when DC power is applied. Available modes to select from: Auto, Manual, Stop mode</p>
All warnings are latched	<p><input type="checkbox"/> = Normal Operation, the warnings and pre-alarms automatically reset once the triggering condition has cleared.</p> <p><input checked="" type="checkbox"/> = Warnings and pre-alarms latch when triggered. Resetting the alarm is performed by either an external reset applied to one of the inputs or, the 'Stop/Reset' pushbutton operated (once the triggering condition has been cleared).</p>
Enhanced Tier IV Home Screen	<p><input type="checkbox"/> = Normal operation, the module shows the default home screen</p> <p><input checked="" type="checkbox"/> = The module's home screen is changed to show the Tier IV Lamps</p>
Show Load Switching Icons	<p><input type="checkbox"/> = The Single Line Diagram on the module's display is removed to allow larger space for the instrumentations</p> <p><input checked="" type="checkbox"/> = The Single Line Diagram is added on the module's display indicating the <i>Load Switching</i> status</p>
Limit Audible Alarm Duration	<p><input type="checkbox"/> = Normal operation, the configured <i>Audible Alarm</i> digital output is active when any alarm is active on the controller. The <i>Audible Alarm</i> digital output is inactive when the alarm is muted or reset.</p> <p><input checked="" type="checkbox"/> = The configured <i>Audible Alarm</i> digital output is active when any alarm is active on the controller for the duration of the <i>Audible Alarm Duration</i> timer. The <i>Audible Alarm</i> digital output is inactive when the alarm is muted or reset or when the <i>Audible Alarm Duration</i> timer expires.</p>
Enable Text Mode	<p><input type="checkbox"/> = Normal operation, all icons that appear on the module's display are pictorial images. .</p> <p><input checked="" type="checkbox"/> = Some of the icons that appear on the module's display are in English text rather than pictorial images.</p>

Power Saving Options

Power Saving Options

Backlight Power Save Mode Enable

Power Save Mode Enable

Deep Sleep Mode Enable

Parameter	Description
Backlight Power Save Mode Enable	<input type="checkbox"/> = Normal operation <input checked="" type="checkbox"/> = Enables DC power saving by turning off the LCD Backlight when the module is not operated for the duration of the <i>Backlight Timer</i> .
Power Save Mode Enable	<div style="border: 1px solid black; padding: 2px;"> <p>NOTE: Available only when Backlight Power Save Mode is enabled.</p> </div> <input type="checkbox"/> = Normal operation <input checked="" type="checkbox"/> = Module goes into power save (low current) mode after inactivity in STOP mode for the duration of the configurable Power Save Mode Delay timer. Press any button to 'wake' the module.
Deep Sleep Mode Enable	<div style="border: 1px solid black; padding: 2px;"> <p>NOTE: Available only when Power Save Mode is enabled.</p> </div> <div style="border: 1px solid black; padding: 2px;"> <p>NOTE: When the module is in <i>Deep Sleep Mode</i>, activating Digital Input A regardless of what it is configured to, awakes the module.</p> </div> <input type="checkbox"/> = Normal operation <input checked="" type="checkbox"/> = The module goes into a deeper sleep state with maximum power saving after inactivity in Power Save Mode for the duration of the configurable Deep Sleep Delay timer.

Instrumentation Suppression

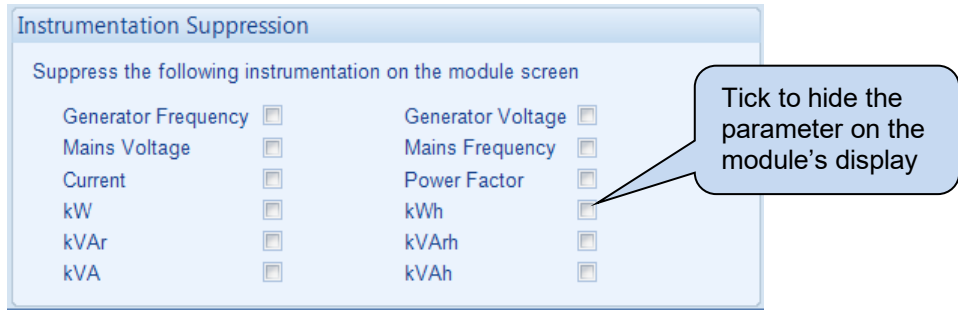

Parameter	Description
Generator Frequency	<input type="checkbox"/> = The <i>Generator Frequency Instrumentation</i> is displayed. <input checked="" type="checkbox"/> = The <i>Generator Frequency Instrumentation</i> is suppressed.
Generator Voltage	<input type="checkbox"/> = The <i>Generator Voltage Instrumentation</i> is displayed. <input checked="" type="checkbox"/> = The <i>Generator Voltage Instrumentation</i> is suppressed.
Mains Supply Frequency	<input type="checkbox"/> = The <i>Mains Frequency Instrumentation</i> is displayed. <input checked="" type="checkbox"/> = The <i>Mains Frequency Instrumentation</i> is suppressed.
Mains Supply Voltage	<input type="checkbox"/> = The <i>Mains Voltage Instrumentation</i> is displayed. <input checked="" type="checkbox"/> = The <i>Mains Voltage Instrumentation</i> is suppressed.
Current	<input type="checkbox"/> = The <i>Current Instrumentation</i> is displayed. <input checked="" type="checkbox"/> = The <i>Current Instrumentation</i> is suppressed.
Power Factor	<input type="checkbox"/> = The <i>Power Factor Instrumentation</i> is displayed. <input checked="" type="checkbox"/> = The <i>Power Factor Instrumentation</i> is suppressed.
kW	<input type="checkbox"/> = The <i>kW Instrumentation</i> is displayed. <input checked="" type="checkbox"/> = The <i>kW Instrumentation</i> is suppressed.
kWh	<input type="checkbox"/> = The <i>kWh Instrumentation</i> is displayed. <input checked="" type="checkbox"/> = The <i>kWh Instrumentation</i> is suppressed.
kvar	<input type="checkbox"/> = The <i>kvar Instrumentation</i> is displayed. <input checked="" type="checkbox"/> = The <i>kvar Instrumentation</i> is suppressed.
kvarh	<input type="checkbox"/> = The <i>kvarh Instrumentation</i> is displayed. <input checked="" type="checkbox"/> = The <i>kvarh Instrumentation</i> is suppressed.
kVA	<input type="checkbox"/> = The <i>kVA Instrumentation</i> is displayed. <input checked="" type="checkbox"/> = The <i>kVA Instrumentation</i> is suppressed.
kVAh	<input type="checkbox"/> = The <i>kVAh Instrumentation</i> is displayed. <input checked="" type="checkbox"/> = The <i>kVAh Instrumentation</i> is suppressed.

2.3 APPLICATION

 **NOTE:** For further details and instructions on ECU (ECM) options and connections, refer to DSE Publication: *057-004 Electronic Engines and DSE Controllers* which are found on our website: www.deepseaelectronics.com

ECU (ECM) Options

Engine Type Conventional Diesel ▾

Alternative Engine Speed

Parameter	Description
Engine Type	<p>Select the appropriate engine type...</p> <p>Conventional Engine: Select this for a traditional (non-electronic) engine, either Energise to Run or Energise to Stop.</p> <p>Conventional Gas Engine: Select this for a traditional (non-electronic) engine and require Gas engine functionality. This enables control of configurable outputs for <i>Gas Choke and Gas Ignition</i> and instructs the module to follow the gas engine timers.</p> <p>Other Engines: The list of supported engine ECUs is constantly updated. To ensure the DSE Configuration Suite is up-to-date to attain the latest releases, navigate to <i>Help</i> menu and <i>Check For Updates</i>.</p>
Alternative Engine Speed	<p><input type="checkbox"/> = The engine is instructed to run at its <i>Nominal Speed</i> as configured by the Engine Manufacturer.</p> <p><input checked="" type="checkbox"/> = The engine is instructed to run at its <i>Alternative Speed</i> as configured by the Engine Manufacturer.</p>

2.4 INPUTS

The *Inputs* section is subdivided into smaller sections. Select the required section with the mouse.

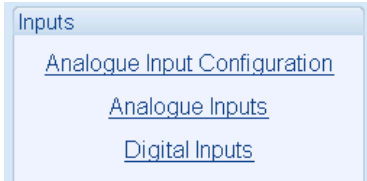

2.4.1 ANALOGUE INPUT CONFIGURATION

ECU (ECM) Options

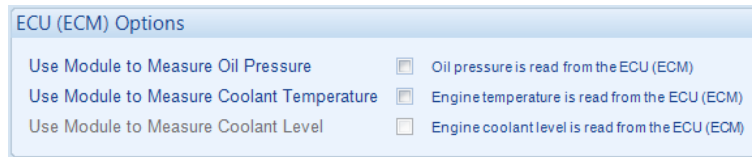

Parameter	Description
Use Module To Measure Oil Pressure	<p>⚠ NOTE: Available only when the module is configured for connection to a CAN engine.</p> <p><input type="checkbox"/> = The measurements are taken from the ECU. <input checked="" type="checkbox"/> = The module ignores the CAN measurement and uses the analogue sensor input.</p>
Use Module To Measure Coolant Temperature	<p>⚠ NOTE: Available only when the module is configured for connection to a CAN engine.</p> <p><input type="checkbox"/> = The measurements are taken from the ECU. <input checked="" type="checkbox"/> = The module ignores the CAN measurement and uses the analogue sensor input.</p>
Use Module To Measure Coolant Level	<p>⚠ NOTE: Available only when the module is configured for connection to a CAN engine.</p> <p><input type="checkbox"/> = The measurements are taken from the ECU. <input checked="" type="checkbox"/> = The module ignores the CAN measurement and uses the analogue sensor input.</p>

Input Configuration

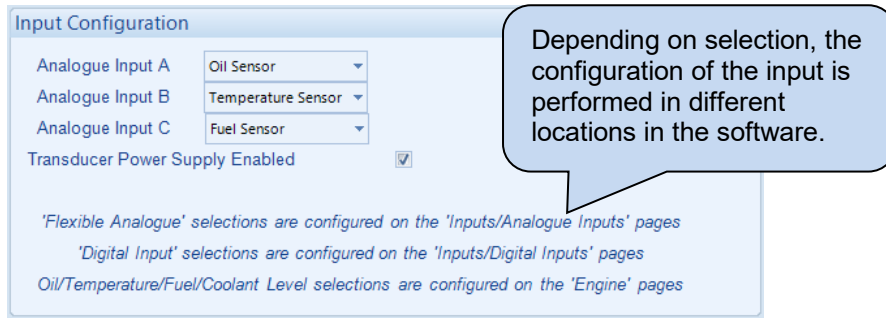

Parameter	Description
Analogue Input A	Select what the analogue input is to be used for: Digital Input: Configured on the <i>Inputs/Digital Inputs</i> pages Flexible Analogue: Configured on the <i>Inputs/Analogue Inputs</i> pages Not Used: The input is disabled Oil Sensor: Configured on the <i>Engine</i> pages Coolant Level: Configured on the <i>Engine</i> pages
Analogue Input B	Select what the analogue input is to be used for: Digital Input: Configured on the <i>Inputs/Digital Inputs</i> pages Temperature Sensor: Configured on the <i>Engine</i> pages Coolant Level: Configured on the <i>Engine</i> pages Not Used: The input is disabled
Analogue Input C	Select what the analogue input is to be used for: Digital Input: Configured on the <i>Inputs/Digital Inputs</i> pages Flexible Analogue : Configured on the <i>Inputs/Analogue Inputs</i> pages Fuel Sensor: Configured on the <i>Engine</i> pages Coolant Level: Configured on the <i>Engine</i> pages Not Used: The input is disabled
Transducer Power Supply Enabled	 NOTE: This option is only available for the 45xx-xxx-07 module variant. <input type="checkbox"/> = Digital Output F operates as a normal user configured digital output. <input checked="" type="checkbox"/> = Digital Output F operates as a 5 V output supply used to power sensors.

2.4.2 ANALOGUE INPUTS

NOTE: An analogue input is only configurable as a flexible sensor if it has been configured as *Flexible Analogue*, refer to section entitled *Analogue Input Configuration* elsewhere in this document for further details.

Input Type

Input Type

VDO Ohm range (10-180) Edit...

Parameter	Description
Input Type	<div style="border: 1px solid black; padding: 5px; margin-bottom: 5px;"> <p>NOTE: Current and Voltage sensor types are only supported on Analogue Input A.</p> </div> <div style="border: 1px solid black; padding: 5px; margin-bottom: 5px;"> <p>NOTE: Current sensor type is only supported on Flexible Sensor A when an external shunt resistor is fitted. For further details on the value and how to connect the shunt resistor, refer to DSE Publication 057-260 DSE4510 MKII & DSE4520 MKII Operator Manual.</p> </div> <p>Select the sensor type and curve from a pre-defined list or create a user-defined curve.</p> <p>Available sensor types: Current: for sensors with maximum range of 0 mA to 20 mA Resistive: for sensors with maximum range of 0 Ω to 240 Ω or 480 Ω Voltage: for sensors with maximum range of 0 V to 10 V</p> <p>Available parameters to be measured: Pressure: The input is configured as a pressure sensor Percentage: The input is configured as a percentage sensor Temperature: The input is configured as a temperature sensor</p>

Sensor Fault Alarm

Sensor Fault Alarm

Enable Alarm

Parameter	Description
Enable Alarm	<p><input type="checkbox"/> = Alarm is disabled.</p> <p><input checked="" type="checkbox"/> = The <i>Flexible Sensor Open Circuit Alarm</i> is active when the module detects an open circuit when the sensor is disconnected</p>

Sensor Alarms

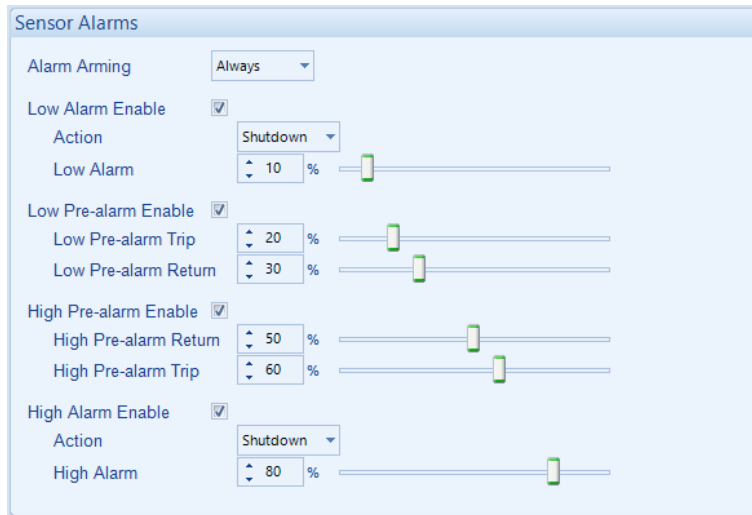

Parameter	Description
Alarm Arming	<p>NOTE: For details of these, see the section entitled <i>Alarm Arming</i> elsewhere in this document.</p> <p>Select when the alarm generated by the analogue input becomes active: Always From Safety On From Starting</p>
Low Alarm Enable	<p><input type="checkbox"/> = The Alarm is disabled. <input checked="" type="checkbox"/> = The <i>Low Alarm</i> activates when the measured quantity drops below the <i>Low Alarm</i> setting.</p>
Low Alarm Action	<p>NOTE: For details of these, see the section entitled <i>Alarm Types</i> elsewhere in this document.</p> <p>Select the type of alarm required from the list: Electrical Trip Shutdown</p>
Low Pre-Alarm Enable	<p><input type="checkbox"/> = The Pre-Alarm is disabled. <input checked="" type="checkbox"/> = The <i>Low Pre-Alarm</i> is active when the measured quantity drops below the <i>Low Pre-Alarm Trip</i> setting. The <i>Low Pre-Alarm</i> is automatically reset when the measured quantity rises above the configured <i>Low Pre-Alarm Return</i> level.</p>
High Pre-Alarm Enable	<p><input type="checkbox"/> = The Pre-Alarm is disabled. <input checked="" type="checkbox"/> = The <i>High Pre-Alarm</i> is active when the measured quantity rises above the <i>High Pre-Alarm Trip</i> setting. The <i>High Pre-Alarm</i> is automatically reset when the measured quantity falls below the configured <i>High Pre-Alarm Return</i> level.</p>
High Alarm Enable	<p><input type="checkbox"/> = The Alarm is disabled. <input checked="" type="checkbox"/> = The <i>High Alarm</i> is active when the measured quantity rises above the <i>High Alarm</i> setting.</p>
High Alarm Action	<p>NOTE: For details of these, see the section entitled <i>Alarm Types</i> elsewhere in this document.</p> <p>Select the type of alarm required from the list: Electrical Trip Shutdown</p>

2.4.2.1 CREATING / EDITING THE SENSOR CURVE

While the *DSE Configuration Suite* holds sensor specifications for the most commonly used resistive sensors, occasionally it is required that the module be connected to a sensor not listed by the *DSE Configuration Suite*. To aid this process, a sensor curve editor is provided.

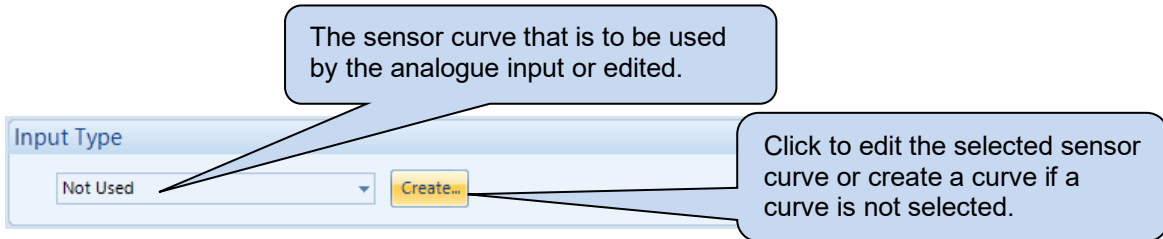

When creating a new sensor curve the measurement quantity and measured parameter are required.

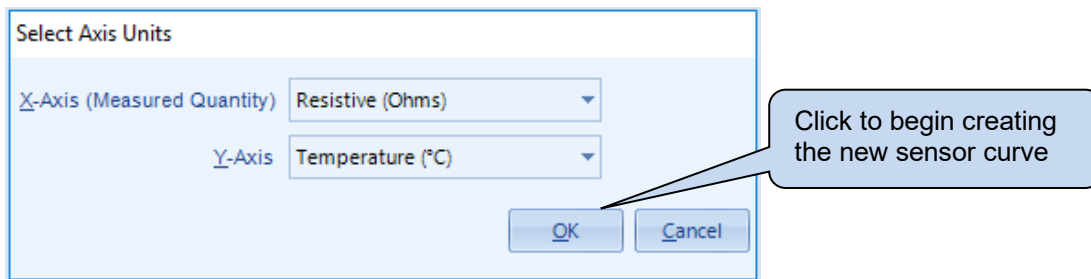

Parameter	Description
X-Axis (Measured Quantity)	Select the electrical quantity that the sensor outputs. Current (mA) : For sensors that output current within a range 0 mA to 20 mA Voltage (Volt) : For sensors that output voltage within a range of 0 V to 10 V Resistive (Ohms) : For sensors that output a resistance within a range 0 Ω to 480 Ω
Y-Axis	Select the parameter that is being monitored by the sensor. Temperature (°C) : For sensors that measure temperature. Pressure (Bar) : For sensors that measure pressure. Percentage (%) : For sensors that measure percentage.

Sensor curve creation / editor descriptions are continued overleaf...

Editing the Configuration

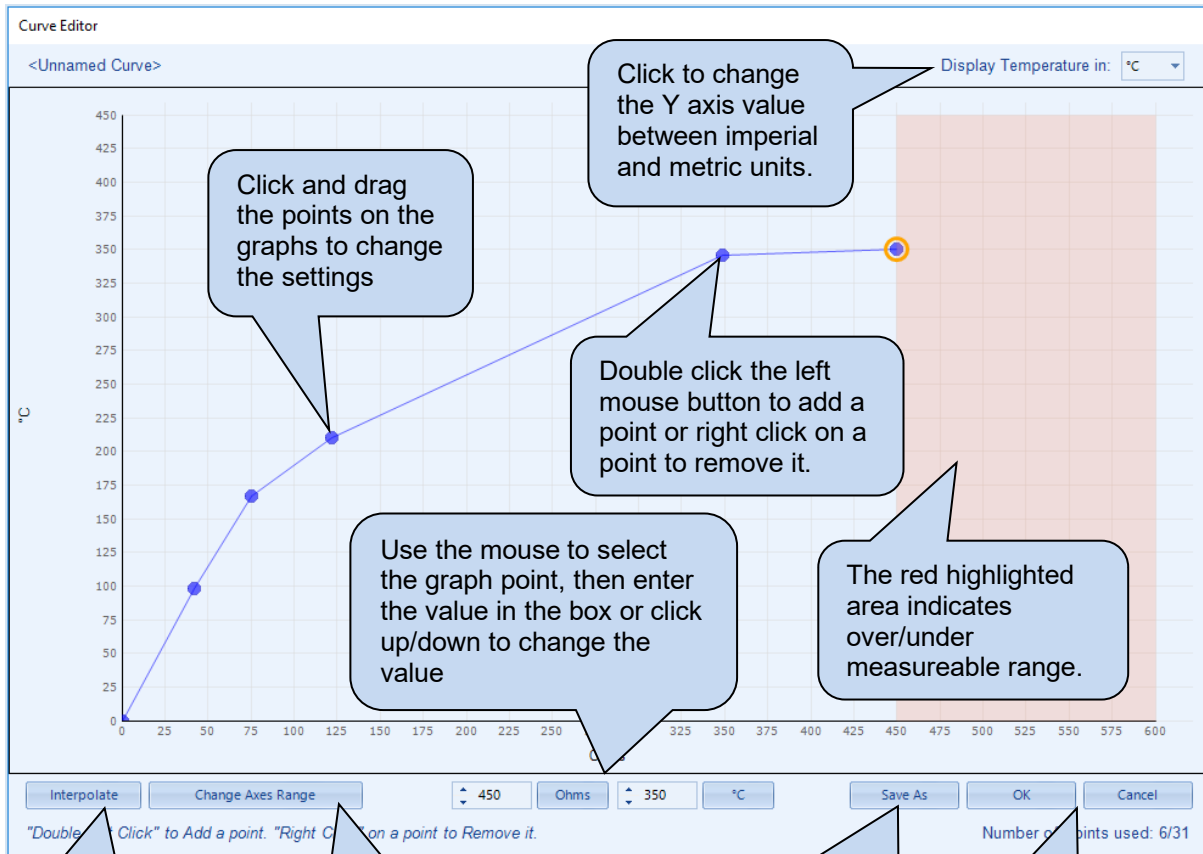

Click *Interpolate* then select two points as prompted to draw a straight line between

Click to change the range of the X and Y Axes of the graph and the level of open circuit

Click **SAVE AS**, a prompt to name the curve...

New Curve Name

Enter a name for the new curve

Click **OK** to accept the changes or **CANCEL** to ignore and lose the

Click **OK** to save the curve.

Any saved curves become selectable in the *Input Type* selection list.

Hint: Deleting, renaming or editing custom sensor curves that have been added is performed in the main menu, select *Tools | Curve Manager*.

2.4.3 DIGITAL INPUTS

The *Digital Inputs* section is subdivided into smaller sections. Select the required section with the mouse.

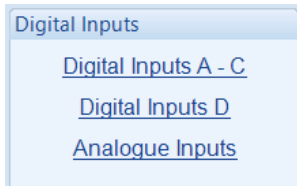

2.4.3.1 DIGITAL INPUTS

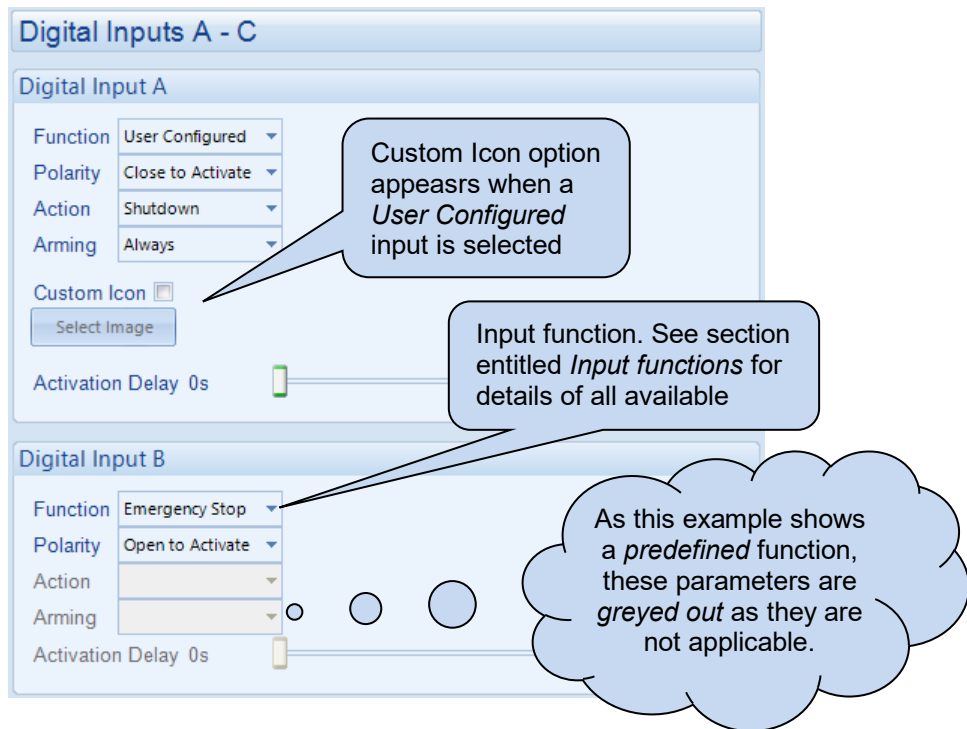

Parameter	Description
Function	Select the input function to activate when the relevant terminal is energised. See section entitled <i>Input functions</i> for details of all available functions
Polarity	Select the digital input polarity: Close to Activate: the input function is activated when the relevant terminal is connected. Open to Activate: the input function is activated when the relevant terminal is disconnected.
Action	<div style="border: 2px solid black; padding: 5px; margin-bottom: 10px;"> <p>NOTE: For details of these, see the section entitled <i>Alarm Types</i> elsewhere in this document.</p> </div> Select the type of alarm required from the list: Electrical Trip Indication Shutdown Warning

Parameter descriptions are continued overleaf...

Parameter	Description
Arming	<p>NOTE: For details of these, see the section entitled <i>Alarm Arming</i> elsewhere in this document.</p> <p>Select when the alarm generated by the input becomes active: Always From Safety On From Starting Never</p>
Custom Icon	<p>Select the icon used for the input when the function is configured as <i>User Configured</i>:</p> <p><input type="checkbox"/> = The <i>Custom Icon</i> is disabled and the standard alarm icons are used. <input checked="" type="checkbox"/> = The <i>Custom Icon</i> is active and is displayed when the input is active.</p>
Select Image	<p>Opens the window to load the <i>Custom Icon</i>. Custom icons must be monochrome bitmap of size (width x height) 24 x 24 pixels.</p>
Activation Delay	<p>This is used to give a delay on acceptance of the input. Useful for liquid level switches or to mask short term operations of the external switch device.</p>

2.4.3.1.1 CUSTOM ICON FOR DIGITAL INPUTS

NOTE: *Custom Icon for Digital Inputs* is only available when the function is configured as *User Configured* input.

The *Custom Icon* function allows the user to upload an alternative icon for *User Configured* digital inputs. The icons are displayed on the modules display when an input is active in place of the default digital input icons.

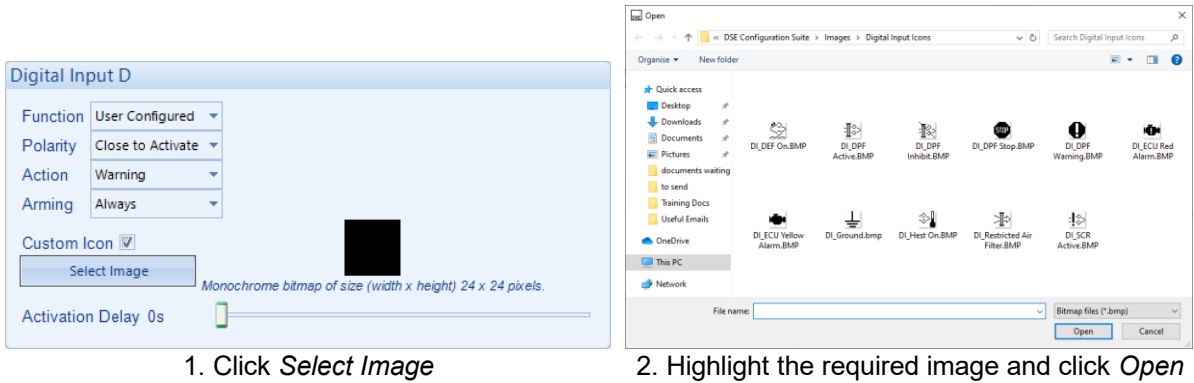

1. Click *Select Image*

2. Highlight the required image and click *Open*

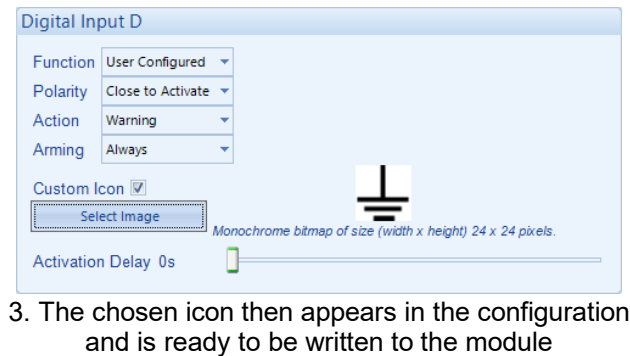

3. The chosen icon then appears in the configuration and is ready to be written to the module

2.4.3.2 ANALOGUE INPUTS

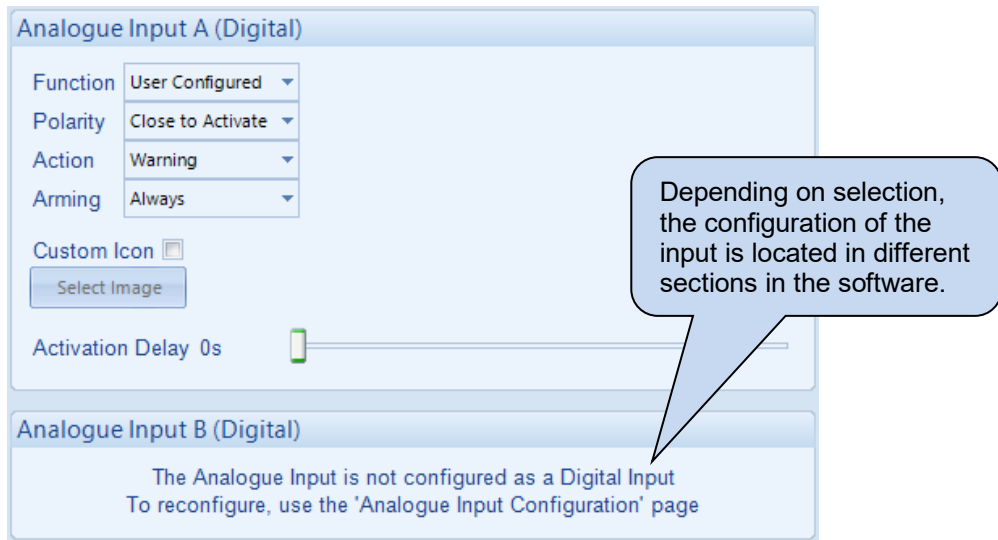



Parameter	Description
Function	Select the input function to activate when the relevant terminal is energised. See section entitled <i>Input functions</i> for details of all available functions
Polarity	Select the digital input polarity: Close to Activate: the input function is activated when the relevant terminal is connected. Open to Activate: the input function is activated when the relevant terminal is disconnected.
Action	<p>NOTE: For details of these, see the section entitled <i>Alarm Types</i> elsewhere in this document.</p> <p>Select the type of alarm required from the list: Electrical Trip Indication Shutdown Warning</p>
Arming	<p>NOTE: For details of these, see the section entitled <i>Alarm Arming</i> elsewhere in this document.</p> <p>Select when the alarm generated by the input becomes active: Always From Safety On From Starting Never</p>
Custom Icon	Select the icon used for the input when the function is configured as <i>User Configured</i> : <input type="checkbox"/> = The <i>Custom Icon</i> is disabled and the standard alarm icons are used. <input checked="" type="checkbox"/> = The <i>Custom Icon</i> is active and is displayed when the input is active.
Select Image	Opens the window to load the <i>Custom Icon</i> . Custom icons must be monochrome bitmap of size (width x height) 24 x 24 pixels.
Activation Delay	This is used to give a delay on acceptance of the input. Useful for liquid level switches or to mask short term operations of the external switch device.

2.4.3.3 INPUT FUNCTIONS

Where a digital input is NOT configured as “user configured”, a selection is made from a list of predefined functions. The selections are as follows:



Under the scope of IEEE 37.2, *function numbers are also used to represent functions in microprocessor devices and software programs.* Where the DSE input functions are represented by IEEE 37.2, the function number is listed below.

Function	Description
Alarm Mute	This input is used to silence the audible alarm from an external source, such as a remote mute switch.
Alarm Reset	This input is used to reset any latched alarms from a remote location. It is also used to clear any latched warnings which may have occurred (if configured) without having to stop the generator.
Alt Config 1, 2 or 3 Select	These inputs are used to instruct the module to follow the relevant <i>alternative</i> configuration settings instead of the <i>main</i> configuration settings.
Auto Restore Inhibit IEEE 37.2 - 3 Checking Or Interlocking Relay 	In the event of a remote start/mains failure, the generator is instructed to start and take load. On removal of the remote start signal/mains return the module continues to run the generator on load until the <i>Auto Restore Inhibit</i> input is removed. This input allows the controller to be fitted as part of a system where the restoration to mains is controlled remotely or by an automated system.
Auto Start Inhibit IEEE 37.2 - 3 Checking Or Interlocking Relay	This input is used to provide an over-ride function to prevent the controller from starting the generator in the event of a remote start/mains out of limits condition occurring. If this input is active and a remote start signal/mains failure occurs the module does not give a start command to the generator. If this input signal is then removed, the controller operates as if a remote start/mains failure has occurred, starting and loading the generator. This function is used to give an ‘AND’ function so that a generator is only called to start if the mains fails and another condition exists which requires the generator to run. If the ‘Auto start Inhibit’ signal becomes active once more it is ignored until the module has returned the mains supply on load and shutdown. This input does not prevent starting of the engine in MANUAL mode.
Auxiliary Mains Fail 	The module monitors the incoming single or three phase supply for Over voltage, Under Voltage, Over Frequency or Under frequency. It may be required to monitor a different mains supply or some aspect of the incoming mains not monitored by the controller. If the devices providing this additional monitoring are connected to operate this input, the controller operates as if the incoming mains supply has fallen outside of limits, the generator is instructed to start and take the load. Removal of the input signal causes the module to act if the mains has returned to within limits providing that the mains sensing also indicates that the mains is within limits.
Coolant Temperature Switch IEEE 37.2 – 26 Apparatus Thermal Device	This input is used to give a <i>Coolant Temperature High</i> shutdown from a digital normally open or closed switch. It allows coolant temperature protection.
DPF Auto Regen Inhibit	This input is used to override the ECU (ECM) function and prevent the automatic regeneration of the diesel particulate filter
DPF Force Regeneration	This input is used to override the ECU (ECM) function and activate the regeneration of the diesel particulate filter
DPF Regeneration Interlock	This input is used to stop a manual regeneration from occurring

Parameter descriptions are continued overleaf...

Function	Description
Emergency Stop	Provides an immediate engine hot shutdown, used in emergency situations
External Panel Lock	<div style="border: 1px solid black; padding: 5px;"> <p>⚠ NOTE: External control sources (i.e. Simulate Start Button) are not affected by the external panel lock input and continue to operate normally.</p> </div> <p>This input is used to provide security to the installation. When the External Panel lock input is active, the module does not respond to operation of the Mode select or Start buttons. This allows the module to be placed into a specific mode (such as Auto) and then secured. The operation of the module is not affected and the operator is still able to view the various instrumentation pages etc. (<i>Front panel configuration access is still possible while the system lock is active</i>).</p>
Fan Speed Low	This input is used where on some engines coolant fans have a switch indicator for low speed or coolant fan failure.
Fuel Tank Bund Level High	A digital normally open or closed fuel tank bund level switch gives this input. It is used to indicate that the fuel tank leaks.
Generator Load Inhibit IEEE 37.2 - 52 AC Circuit Breaker	<div style="border: 1px solid black; padding: 5px;"> <p>⚠ NOTE: This input only operates to control the generator-switching device if the module load switching logic is attempting to load the generator. It does not control the generator switching device when the mains supply is on load.</p> </div> <p>This input is used to prevent the module from loading the generator. If the generator is already on load, activating this input causes the module to unload the generator. Removing the input allows the generator to be loaded again.</p>
Lamp Test	This input is used to provide a test facility for the front panel indicators fitted to the module. When the input is activated all LEDs illuminate.
Low Coolant Level Switch IEEE 37.2 - 71 Liquid Level Switch	This input is used to allow feedback for low coolant level.
Low Fuel Level Switch IEEE 37.2 - 71 Liquid Level Switch	This input is used to allow feedback for low fuel level.
Main Config Select	This input is used to select the <i>Main</i> configuration when <i>Alternative Configurations</i> are enabled.
Mains Load Inhibit IEEE 37.2 - 3 Checking or Interlocking Relay 	<div style="border: 1px solid black; padding: 5px;"> <p>⚠ NOTE: This input only operates to control the mains switching device if the module load switching logic is attempting to load the mains. It does not control the mains switching device when the generator is on load.</p> </div> <p>This input is used to prevent the module from loading the mains supply. If the mains supply is already on load activating this input causes the module to unload the mains supply. Removing the input allows the mains to be loaded again.</p>
Maintenance Reset Alarm Air	Provides an external digital input to reset the maintenance alarm
Maintenance Reset Alarm Fuel	Provides an external digital input to reset the maintenance alarm
Maintenance Reset Alarm Oil	Provides an external digital input to reset the maintenance alarm
Oil Pressure Switch IEEE 37.2 - 63 Pressure Switch	A digital normally open or closed oil pressure switch gives this input. It allows low oil pressure protection.

Parameter descriptions are continued overleaf...

Function	Description
Remote Start Off Load	If this input is active, operation is similar to the 'Remote Start on load' function except that the generator is not instructed to take the load. This function is used where an engine only run is required e.g. for exercise.
Remote Start On Load	When in auto mode, the module performs the start sequence and transfer load to the generator. In Manual mode, the load is transferred to the generator if the engine is already running, however in manual mode, this input does not generate start/stop requests of the engine.
Simulate Auto Button	<div style="border: 1px solid black; padding: 5px; margin-bottom: 5px;"> <p>⚠ NOTE: If a call to start is present when AUTO MODE is entered, the starting sequence begins. Call to Start comes from a number of sources depending upon module type and configuration and includes (but is not limited to) : Remote start input present, Mains failure, Scheduled run, Auxiliary mains failure input present, Telemetry start signal from remote locations.</p> </div> <p>This input mimics the operation of the 'Auto' button and is used to provide a remotely located Auto mode push button.</p>
Simulate Mains Available 	This function is provided to override the module's internal monitoring function. If this input is active, the module does not respond to the state of the incoming AC mains supply.
Simulate Start Button	This input mimics the operation of the 'Start' button and is used to provide a remotely located start push button.
Simulate Stop Button	This input mimics the operation of the 'Stop' button and is used to provide a remotely located stop/reset push button.
Smoke Limiting IEEE 37.2 – 18 Accelerating or Decelerating Device	This input instructs the module to give a <i>run at idle speed</i> command to the engine either via an output configured to <i>smoke limit</i> or by data commands when used with supported electronic engines.
Transfer To Generator/Open Mains IEEE 37.2 - 52 AC Circuit Breaker 	This input is used to transfer the load to the generator when running in MANUAL MODE
Transfer To Mains/ Open Generator IEEE 37.2-52 AC Circuit Breaker 	This input is used to transfer the load to the mains supply when running in MANUAL MODE
Wait To Start	The <i>Wait To Start</i> prevents the starting procedure and is effective in both manual and automatic mode. This delay follows and is in addition to any other configured starting delays.
Water in Fuel	This input is used where on some engines water separators have a switch indicator for water detection. The input is used as normally open or normally closed.

2.5 OUTPUTS

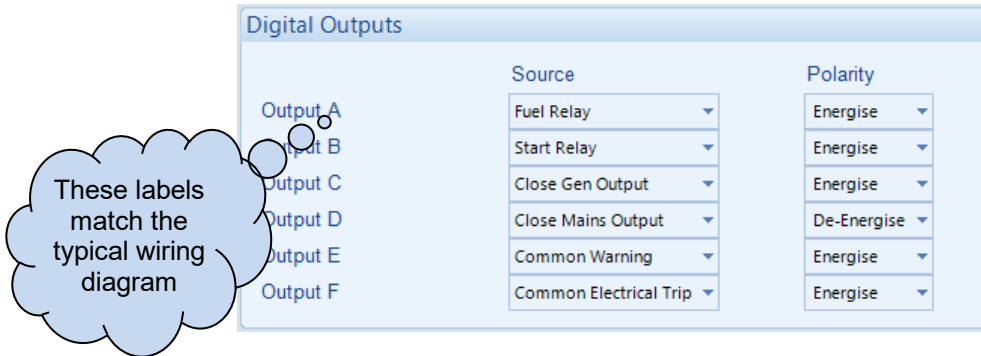

Parameter	Description
Source	Select the output source to control the state of the output See section entitled <i>Output Sources</i> for details of all available functions
Polarity	Select the digital output polarity: De-Energise: When the output source is true, the output deactivates. Energise: When the output source is true, the output activates.

2.5.1 OUTPUT SOURCES



The list of output sources available for configuration of the module digital outputs.

Under the scope of IEEE 37.2, *function numbers* is also used to represent functions in microprocessor devices and software programs. Where the DSE output functions is represented by IEEE 37.2, the function number is listed below.

Output Source	Activates...	Is Not Active...
Not Used	The output does not change state (Unused)	
Air Filter Maintenance	Active when the <i>Air Filter Maintenance Alarm</i> is due.	
Air Flap Relay	Normally used to control an air flap, this output becomes active upon an Emergency Stop or Over-speed situation.	Inactive when the set has come to rest
Alternative Config 1, 2 or 3 Selected	Active when the alternative configuration is selected.	
Analogue Input A, B & C (Digital)	Active when the relevant analogue input is configured as digital and is active	
Audible Alarm IEEE 37.2 – 74 Alarm Relay	Use this output to activate an external sounder or external alarm indicator. Activation of the <i>Alarm Mute</i> input resets this output once activated	Inactive if no alarm condition is active or <i>Alarm Mute</i> input was active
Battery High Voltage IEEE 37.2 – 59 DC Overvoltage Relay	This output indicates that a Battery Over voltage alarm has occurred	Inactive when battery voltage is not High
Battery Low Voltage IEEE 37.2 – 27 DC Undervoltage Relay	This output indicates that a Battery Under Voltage alarm has occurred.	Inactive when battery voltage is not Low
Charge Alternator Failure Shutdown	Active when the charge alternator shutdown alarm is active	
Charge Alternator Failure Warning	Active when the charge alternator warning alarm is active	

Parameter descriptions are continued overleaf...

Editing the Configuration

Output Source	Activates...	Is Not Active...
Close Gen Output IEEE 37.2 – 52 AC Circuit Breaker	Used to control the load switching device. Whenever the module selects the generator to be on load this control source is activated.	Inactive whenever the generator is not required to be on load
Close Gen Output Pulse IEEE 37.2 – 52 AC Circuit Breaker	Used to control the load switching device. Whenever the module selects the generator to be on load this control source is activated for the duration of the Breaker Close Pulse timer, after which it becomes inactive again.	
Close Mains Output IEEE 37.2 – 52 AC Circuit Breaker 	Used to control the load switching device. Whenever the module selects the mains to be on load this control source is activated.	The output is inactive whenever the mains is not required to be on load
Close Mains Output Pulse IEEE 37.2 – 52 AC Circuit Breaker 	Used to control the load switching device. Whenever the module selects the mains to be on load this control source is activated for the duration of the Breaker Close Pulse timer, after which it becomes inactive again.	
Combined Mains Failure 	Active when the mains supply is out of limits OR the input for Auxiliary Mains Failure is active	
Common Alarm	Active when one or more alarms (of any type) are active	The output is inactive when no alarms are present
Common Electrical Trip	Active when one or more <i>Electrical Trip</i> alarms are active	The output is inactive when no shutdown alarms are present
Common Shutdown	Active when one or more <i>Shutdown</i> alarms are active	The output is inactive when no shutdown alarms are present
Common Warning	Active when one or more <i>Warning</i> alarms are active	The output is inactive when no warning alarms are present
Coolant Cooler Control	Active by the <i>Coolant Cooler Control</i> in conjunction with the Coolant Temperature Sensor	
Coolant Heater Control	Active by the <i>Coolant Heater Control</i> in conjunction with the Coolant Temperature Sensor	
Cooling Down	Active when the Cooling timer is in progress	
DEF Level Low	Active when <i>DEF Level Low CAN</i> alarm is active.	
Delayed Load Output 1, 2, 3 & 4	Provide delayed outputs for controlling load switching devices	
Digital Input A, B, C & D	Active when the relevant digital input is active	
Display Heater Fitted and On	Active when the display heater is on	
DPF Auto Regeneration Inhibit Request	Active when the <i>DPF Auto Regeneration Inhibit</i> is active	
DPF Forced Regeneration Interlock Active	Active when the <i>DPF Force Regeneration Interlock</i> is active	
DPF Forced Regeneration Requested	Active when the <i>DPF Force Regeneration</i> is active	
DPF Non Mission State	Active when the <i>DPF Non-Mission State</i> is active	
DPF Regeneration In Progress	Active when the <i>DPF Regeneration</i> is in progress	
DPF Regeneration Interlock Active	Active when the <i>DPF Regeneration Interlock</i> is active	
DPTC Filter	Active when the diesel particulate filter CAN alarm is active	

Parameter descriptions are continued overleaf...

Editing the Configuration

Output Source	Activates...	Is Not Active...
ECU (ECM) Data Fail	Becomes active when no CANbus data is received from the ECU after the safety delay timer has expired	Inactive when: <ul style="list-style-type: none"> CANbus data is being received The set is at rest During the starting sequence before the safety delay timer has expired
ECU (ECM) Power	Used to switch an external relay to power the CANbus ECU (ECM). Exact timing of this output is dependent upon the type of the engine ECU (ECM)	
ECU (ECM) Shutdown	The engine ECU (ECM) has indicated that a Shutdown alarm is present.	Inactive when no Shutdown alarm from the ECU (ECM) is present
ECU (ECM) Stop	Active when the DSE controller is requesting that the CANbus ECU (ECM) stops the engine.	
ECU (ECM) Warning	The engine ECU (ECM) has indicated that a Warning alarm is present.	Inactive when no Warning alarm from the ECU (ECM) is present
ECU Pre-Heat	Active when the <i>ECU Pre-Heat</i> is active	
Emergency Stop IEEE 37.2 – 5 Stopping Device	Active when the <i>Emergency Stop</i> input has been activated	
Energise To Stop	Normally used to control an <i>Energise to Stop</i> solenoid, this output becomes active when the controller wants the set to stop running.	Becomes inactive a configurable amount of time after the set has stopped. This is the <i>ETS hold time</i> .
Fail To Start IEEE 37.2 - 48 Incomplete Sequence Relay	Becomes active if the set is not seen to be running after the configurable number of start attempts	
Fail To Stop IEEE 37.2 - 48 Incomplete Sequence Relay	If the set is still running a configurable amount of time after it has been given the stop command, the output becomes active. This configurable amount of time is the <i>Fail to Stop Timer</i> .	
Fan Speed Low	Active when the <i>Fan Speed Low</i> alarm input is active	
Flexible Sensor A and C Low/High – Alarm/Pre- Alarm	Active when the relevant flexible sensor alarm is active	
Fuel Bund Level High	Active when the <i>Fuel Bund Level High Alarm</i> input is active.	
Fuel Filter Maintenance	Indicates that the fuel filter maintenance alarm is due	
Fuel Level High Alarm/Pre-Alarm	Active when the relevant High Fuel Level alarm is active	
Fuel Level Low Alarm/Pre-Alarm	Active when the relevant Low Fuel Level alarm is active	
Fuel Pull in Coil	Becomes active for the <i>Fuel Pull Coil Duration</i> amount of time when the <i>Fuel Relay</i> output is energised.	Becomes inactive when the <i>Fuel Pull Coil Duration</i> timer expires, or when the Fuel Relay output is de-energised.
Fuel Relay	Becomes active when the controller requires the governor/fuel system to be active.	Becomes inactive whenever the set is to be stopped, including between crank attempts, upon controlled stops and upon fault shutdowns.
Fuel Tank Bund Level High	Active when the digital input configured for <i>Fuel Tank Bund Level High</i> is active.	
Fuel Usage Alarm	Becomes active when the controller detects excess fuel usage.	



Parameter descriptions are continued overleaf...

Editing the Configuration

Output Source	Activates...	Is Not Active....
Gen Over Frequency Overshoot Alarm <i>IEEE 37.2 – 81 Frequency Relay</i>	Becomes active when the <i>Over Frequency Overshoot</i> alarm is active	
Generator At Rest	Becomes active when the generator is at rest.	
Generator Available	Becomes active when the generator is available to take load.	Inactive when <ul style="list-style-type: none"> • <i>Loading voltage</i> and <i>loading frequency</i> have not been reached • After <i>electrical trip</i> alarm • During the starting sequence before the end of the warming timer.
Generator High Voltage Alarm/Warning <i>IEEE 37.2 – 59 AC Overvoltage Relay</i>	Active when the <i>High Voltage Shutdown / High Voltage Warning</i> alarm is active	
Generator Low Voltage Alarm <i>IEEE 37.2 – 27 AC Undervoltage Relay</i>	Active when the generator voltage falls below the <i>Under Voltage Alarm Trip</i> level	Inactive when <ul style="list-style-type: none"> • The set is stopped • During starting sequence before the safety delay time has expired.
Generator Low Voltage Warning	Active when the generator voltage falls below the <i>Under Voltage Alarm Pre-Alarm</i> level	Inactive when <ul style="list-style-type: none"> • The set is stopped • During starting sequence before the safety delay time has expired.
Generator Over Frequency Shutdown <i>IEEE 37.2 – 81 Frequency Relay</i>	Active when the generator frequency exceeds the <i>Over Frequency Shutdown Trip</i> level.	
Generator Over Frequency Warning	Active when the generator frequency exceeds the <i>Over Frequency Pre-Alarm Trip</i> level.	
Generator Under Frequency Shutdown <i>IEEE 37.2 – 81 Frequency Relay</i>	Active when the generator frequency drops below the <i>Under Frequency Shutdown Trip</i> level.	
Generator Under Frequency Warning	Active when the generator frequency drops below the <i>Under Frequency Pre-Alarm Trip</i> level.	
HEST Active	Active when the High Exhaust System Temperature CAN alarm is active	
High Coolant Temperature Shutdown <i>IEEE 37.2 – 26 Apparatus Thermal Device</i>	Active when the <i>Coolant Temperature</i> exceeds the configured <i>High Coolant Temperature Shutdown</i> level	
High Coolant Temperature Shutdown <i>IEEE 37.2 – 26 Apparatus Thermal Device</i>	Active when the <i>Coolant Temperature</i> exceeds the configured <i>High Coolant Temperature Warning</i> level	
kW Overload Alarm	Active when the measured kW are above the setting of the <i>kW overload alarm</i> . Used to give alarms on overload, control a dummy load switch or for load shedding functionality.	
Low Coolant Level <i>IEEE 37.2 - 71 Liquid Level Switch</i>	Active when the <i>Low Coolant Level</i> alarm is active.	
Low Coolant Level Switch <i>IEEE 37.2 - 71 Liquid Level Switch</i>	Active when the <i>Low Coolant Level Switch</i> alarm is active.	

Parameter descriptions are continued overleaf...

Editing the Configuration

Output Source	Activates...	Is Not Active....
Low Coolant Level Open Circuit	Active when the <i>Low Coolant Level Switch</i> alarm is active.	
Low Oil Pressure Shutdown IEEE 37.2 - 63 Pressure Switch	Active when the <i>Oil Pressure</i> falls below the <i>Low Oil Pressure Shutdown</i> setting	Inactive when <ul style="list-style-type: none"> • The set is stopped • During starting sequence before the safety delay time has expired.
Main Config Selected	Active when the main configuration is active	
Mains High Frequency IEEE 37.2 - 81 Frequency Relay	Active when the mains frequency exceeds the <i>High Frequency</i> setting	
Mains High Voltage IEEE 37.2 - 59 AC Overvoltage Relay	Active when the mains voltage exceeds the <i>High Voltage</i> setting	
Mains Low Frequency IEEE 37.2 - 81 Frequency Relay	Active when the mains frequency falls below the <i>Low Frequency</i> setting	
Mains Low Voltage IEEE 37.2 - 27 AC Undervoltage Relay	Active when the mains voltage falls below the <i>Low Voltage</i> setting	
Oil Filtler Maintenance	Active when the relevant maintenance alarm is due.	
Oil Pressure Sender Open Circuit	Active when the <i>Oil Pressure Sensor</i> is detected as being open circuit.	
Open Gen Output IEEE 37.2 - 52 AC Circuit Breaker	Used to control the load switching device. Whenever the module selects the generator to be off load this control source is activated.	Inactive whenever the generator is required to be on load
Open Gen Output Pulse IEEE 37.2 - 52 AC Circuit Breaker	Used to control the load switching device. Whenever the module selects the generator to be off load this control source is activated for the duration of the Breaker Open Pulse timer, after which it becomes inactive again.	
Open Mains Output IEEE 37.2 - 52 AC Circuit Breaker 	Used to control the load switching device. Whenever the module selects the mains to be off load this control source is activated.	The output is inactive whenever the mains is required to be on load
Open Mains Output Pulse IEEE 37.2 - 52 AC Circuit Breaker 	Used to control the load switching device. Whenever the module selects the mains to be off load this control source is activated for the duration of the Breaker Open Pulse timer, after which it becomes inactive again.	
Over Current Delayed Alarm	Active when the <i>Over Current Delayed</i> alarm is active	
Over Current Immediate Warning	Active when the <i>Over Current Immediate Warning</i> alarm is active	
Over Speed Shutdown IEEE 37.2 - 12 Over Speed Device	Active when the <i>Over Speed Shutdown</i> alarm is active	
Over Speed Overshoot Alarm IEEE 37.2 - 12 Over Speed Device	Active when the <i>Over Speed Overshoot</i> alarm is active	
Preheat During Preheat Timer	Becomes active when the preheat/postheat timer begins. Normally used to control the engine preheat glow-plugs.	Inactive when : <ul style="list-style-type: none"> • The set is stopped • The preheat timer has expired
Preheat Until End Of Cranking	Becomes active when the preheat/postheat timer begins. Normally used to control the engine preheat glow-plugs.	Inactive when : <ul style="list-style-type: none"> • The set is stopped • The set has reached <i>crank disconnect</i> conditions

Parameter descriptions are continued overleaf...

Editing the Configuration

Output Source	Activates...	Is Not Active....
Preheat Until End Of Safety Timer	Becomes active when the preheat timer begins. Normally used to control the engine preheat glow-plugs.	Inactive when : <ul style="list-style-type: none"> The set is stopped The set has reached the end of the <i>safety delay</i> timer
Preheat Until End of Warming Timer	Becomes active when the preheat timer begins. Normally used to control the engine preheat glow-plugs.	Inactive when : <ul style="list-style-type: none"> The set is stopped The set has reached the end of the <i>warming</i> timer
SCR Inducement	Active when <i>SCR Inducement CAN Alarm</i> is active	
Smoke Limiting	Becomes active when the controller requests that the engine runs at idle speed. As an output, this is used to give a signal to the <i>Idle Speed Input</i> on the engine speed governor (if available)	Becomes inactive when the controller requests that the engine runs at rated speed.
Start Relay IEEE 37.2 – 54 Turning Gear Engaging Device	Active when the controller requires the cranking of the engine.	
System in Auto Mode	Active when Auto mode is selected	
System in Manual Mode	Active when Manual mode is selected	
System in Stop Mode	Active when Stop mode is selected	
Temperature Sensor Open Circuit	Active when the <i>Temperature Sensor Open Circuit</i> alarm is active	
Under Speed Shutdown	Active when any of the <i>Underspeed Shutdown</i> or <i>Electrical Trip</i> alarms are active	
Waiting For Manual Restore 	Becomes active when the generator is on load and the mains supply is healthy but an input configured to Manual Restore is active. This is used to signal to an operator that action is required before the set transfers back to the mains supply.	
Waiting To Start	Active when the <i>Waiting To Start</i> function is active	
Water in Fuel	Active when the <i>Water in Fuel</i> input is active, or when the module is informed of the <i>Water in Fuel</i> CAN message from the ECU.	

2.6 TIMERS

Many timers are associated with alarms. Where this occurs, the timer for the alarm is located on the same page as the alarm setting. Timers not associated with an alarm are located on the timers page. The *Timers* page is subdivided into smaller sections. Select the required section with the mouse.

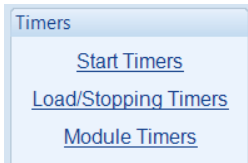

2.6.1 START TIMERS

Timer	Value
Mains Transient Delay	2s
Start Delay	5s
Delay Crank	0.5s
Max Start Pause Time	90m
Cranking	10.0 s
Cranking Rest	10s
Smoke Limiting	0s
Smoke Limiting Off	0s
DPF Ramp	5.0s
Safety On Delay	10s
Warming	1s
Fuel Pull In Coil Duration	1.0s
ECU Override	2m

Timer	Description
 Mains Transient Delay	Used to give a delay between sensing mains failure and acting upon it. This is used to prevent dropouts of the mains load switch and operation of the system due to mains supply transient conditions.
Start Delay	The amount of time delay before starting in AUTO mode. This timer is activated upon the <i>Remote Start On Load/Off Load</i> command being issued or a mains failure detection. Typically this timer is applied to prevent starting upon fleeting start signals.
Delay Crank	The amount of time delay between the fuel relay and the crank relay energising. This is typically used to allow fuel systems to prime.
Max Start Pause Timer	The amount of time the <i>Wait To Start</i> function is active before activating the <i>Fail To Start</i> alarm.
Cranking	The amount of time for each crank attempt
Cranking Rest	The amount of time between multiple crank attempts.

Continued overleaf.....

Editing the Configuration

Timer	Description
Smoke Limiting	The amount of time that the engine is requested to run at idle speed upon starting. This is typically used to limit emissions at startup.
Smoke Limiting Off	The amount of time that the engine takes to run up to rated speed after removal of the command to run at idle speed. If this time is too short, the engine is stopped due to an <i>Underspeed</i> alarm. If the time is too long, <i>Underspeed</i> protection is disabled until the <i>Smoke Limit Time Off</i> time has expired.
DPF Ramp	The amount of time that the engine takes to run up to rated speed after a DPF session.
Safety On Delay	The amount of time at startup that the controller ignores oil pressure and engine speed and other delayed alarms. This is used to allow the engine to run up to speed before protections are activated.
Warming	The amount of time the engine runs before being allowed to take load. This is used to warm the engine to prevent excessive wear.
Fuel Pull in Coil Duration	The amount of time for the <i>Fuel Pull in Coil</i> output stay energised when the <i>Fuel Relay</i> output is energised.
ECU (ECM) Override	The amount of time the CAN ECU Power stays energised when the periodic ECU Wake Up is enabled.

2.6.2 LOAD / STOPPING TIMERS

Load Control Timers

The screenshot shows a configuration window titled "Load Control Timers". It contains three rows, each with a parameter name, a numerical value, and a slider control. The first row is "Transfer Delay" with a value of "0.7s". The second row is "Breaker Trip Pulse" with a value of "0.5s". The third row is "Breaker Close Pulse" with a value of "0.5s".

Timer	Description
 Transfer Delay	The time between one load switch opening and the other closing. Used during transfer to and from the generator.
Breaker Close Pulse	The amount of time that <i>Breaker Close Pulse</i> signal is present when the request to close the load switch is given.
Breaker Trip Pulse	The amount of time that <i>Breaker Open Pulse</i> signal is present when the request to open the load switch is given.

Load Delay Timers

The screenshot shows a configuration window titled "Load Delay Timers". It contains four rows, each with a parameter name, a numerical value, and a slider control. All four rows are "Delay Load Output 1", "Delay Load Output 2", "Delay Load Output 3", and "Delay Load Output 4", all with a value of "0s". A callout box points to the sliders with the text: "Respective digital outputs, when configured, become energised after the respective load delay timer expires."

Timer	Description
Delay Load Output 1, 2, 3 & 4	The time delay before energising the configured "Delayed Load" outputs. These outputs are used to control additional load breakers to provide five stage loading. After the generator load switch is closed, the remaining four outputs are closed after the configurable time delay. This allows for additional loads to be energised in sequence, minimising the size of step loading of the generator

Stopping Timers

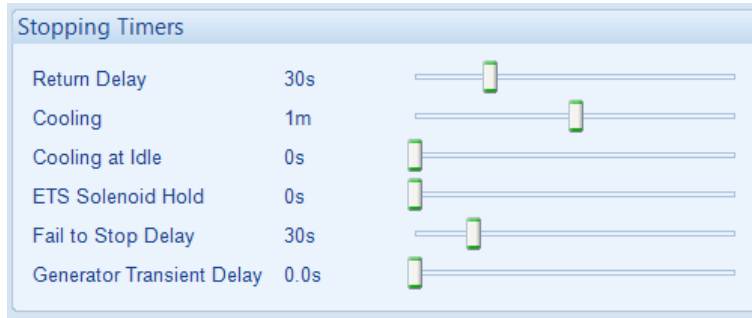

Timer	Description
Return Delay	A delay, used in auto mode only, that allows for short term removal of the request to stop the set before action is taken. This is usually used to ensure the set remains on load before accepting that the start request has been removed.
Cooling	The amount of time that the set is made to run OFF LOAD before being stopped. This is to allow the set to cool down and is particularly important for engines with turbo chargers.
Cooling at Idle	The amount of time the generator runs at an idle speed after the <i>Cooling Time</i> has expired
ETS Solenoid Hold	The amount of time the <i>Energise to stop</i> solenoid is kept energised after the engine has come to rest. This is used to ensure the set has fully stopped before removal of the stop solenoid control signal.
Fail To Stop Delay	If the set is called to stop and is still running after the <i>fail to stop</i> delay, a <i>Fail to Stop</i> alarm is generated.
Generator transient Delay	Used to delay the generator under/over volts/frequency alarms. Typically this is used to prevent spurious shutdown alarms caused by large changes in load levels.

2.6.3 MODULE TIMERS

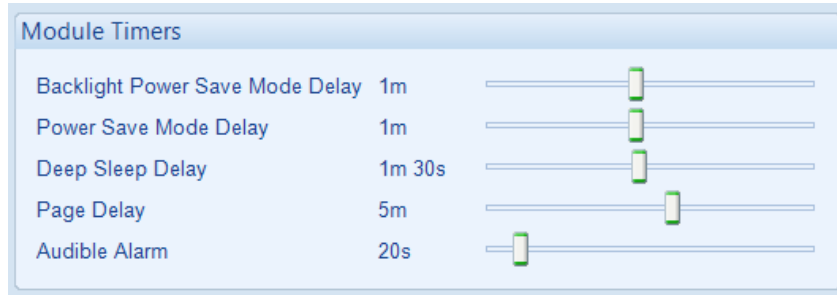

Timer	Description
Backlight Power Save Mode Delay	When the module is left unattended for the duration of the <i>Backlight Power Save Mode Delay</i> time its LCD backlight turns off. Pressing a control button when the LCD backlight is off, causes to turn the backlight on again, and the module changes to the relevant button control mode. And pressing an up/down button turns the backlight on again without changing the screen page.
Power Save Mode Delay	When the module is left unattended in STOP mode for the duration of the <i>Power Save Mode Delay</i> it enters low power consumption mode (Power Save Mode).
Deep Sleep Delay	When the module is in Power Save Mode, if left unattended for the duration of the <i>Deep Sleep Mode Delay</i> timer it will enter a lower power consumption mode (Deep Sleep Mode).
Page Delay	If the module is left unattended for the duration of the Page Delay Timer it will revert to show the Status page.
Audible Alarm	When an alarm is active on the module, this is the time duration during which the <i>Audible Alarm</i> digital output is active. This is configurable when the <i>Limit Audible Alarm Duration</i> option is enabled under <i>Module Options</i> .

2.7 GENERATOR

The *Generator* section is subdivided into smaller sections. Select the required section with the mouse.

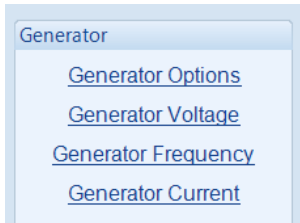

2.7.1 GENERATOR OPTIONS

Alternator

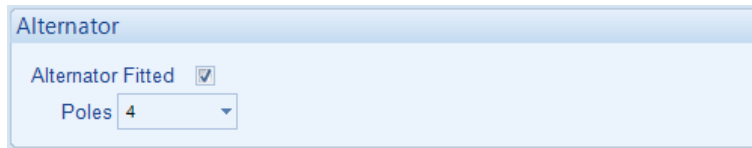

Parameter	Description
Alternator Fitted	<input type="checkbox"/> = There is no alternator in the system, it is an <i>engine only</i> application <input checked="" type="checkbox"/> = An alternator is fitted to the engine, it is a generator application.
Poles	The number of poles on the alternator

System Topology

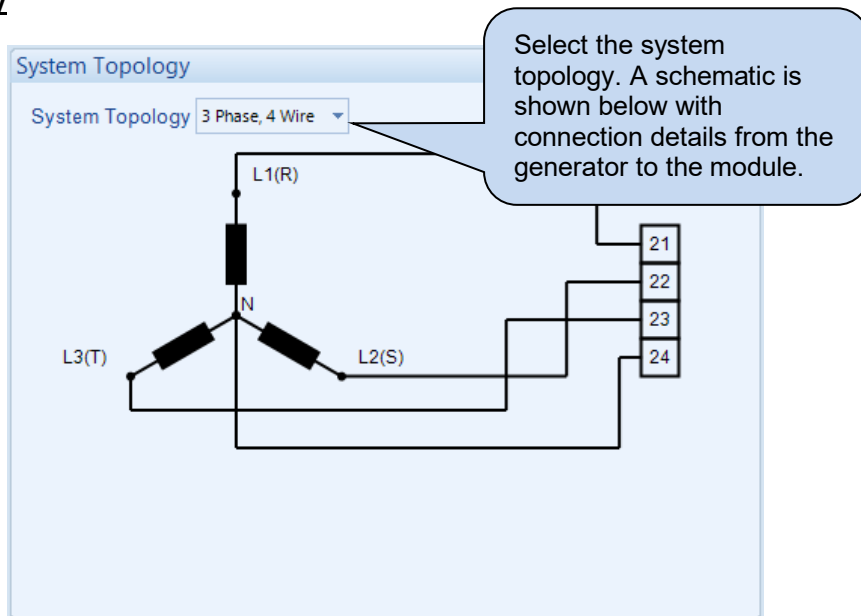

Parameter	Description
System Topology	Select the AC topology of the generator from the following list: 2 Phase, 3 Wire L1 - L2 2 Phase, 3 Wire L1 - L3 3 Phase, 3 Wire 3 Phase, 4 Wire 3 Phase, 4 Wire Delta Single Phase, 2 Wire

2.7.2 GENERATOR VOLTAGE

Under Voltage Alarms

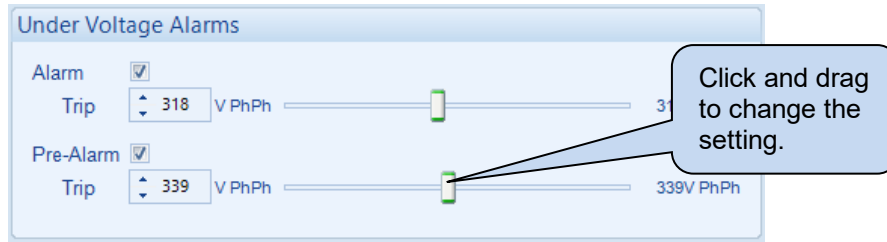

Parameter	Description
Generator Under Voltage Alarm IEEE 37.2 - 27AC Undervoltage Relay	<input type="checkbox"/> = Generator Under Volts does NOT give an alarm <input checked="" type="checkbox"/> = Generator Under Volts gives an alarm in the event of the generator output falling below the configured <i>Under Volts Alarm Trip</i> value for longer than the <i>Generator Transient Delay</i> . The <i>Under-volts Alarm Trip</i> value is adjustable to suit user requirements.
Generator Under Voltage Pre-Alarm IEEE 37.2 - 27AC Undervoltage Relay	<input type="checkbox"/> = Generator Under Volts does NOT give a warning alarm <input checked="" type="checkbox"/> = Generator Under Volts gives a warning alarm in the event of the generator output falling below the configured <i>Under Volts Pre-Alarm Trip</i> value for longer than the <i>Generator Transient Delay</i> . The <i>Under-volts Pre-Alarm Trip</i> value is adjustable to suit user requirements.

Loading Voltage

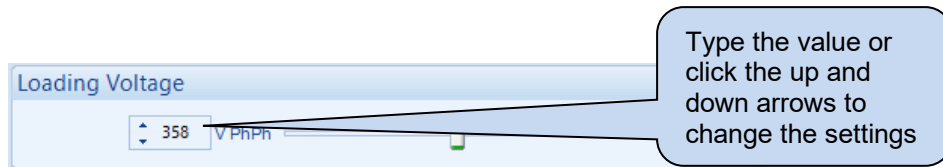

Parameter	Description
Loading Voltage	This is the minimum voltage the generator must be operating at before the module considers it available to take the load. It is also the voltage above the under voltage trip that the generator output must return to before the module considers that the supply is back within limits. (i.e. With an under voltage trip of 184 V and a loading voltage of 207 V, the output voltage must return to 207 V following an under voltage event to be considered within limits.)

Nominal Voltage

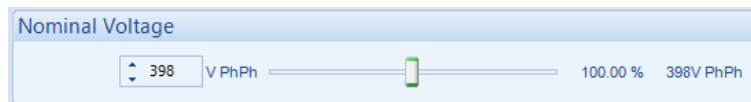

Parameter	Description
Nominal Voltage	This is used to calculate the percentages of the alarm set points

Over Voltage Alarms

Parameter	Description
Generator Over Voltage Pre-Alarm IEEE 37.2 – 59 AC Overvoltage Relay	<input type="checkbox"/> = Alarm is disabled <input checked="" type="checkbox"/> = Generator Over Volts gives a warning alarm in the event of the generator output voltage rising above the configured <i>Over Volts Pre-Alarm Trip</i> value for longer than the <i>Generator Transient Delay</i> . The <i>Warning</i> is automatically reset when the generator output voltage falls below the configured <i>Return</i> level. The <i>Over Volts Pre-Alarm Trip</i> value is adjustable to suit user requirements.
Generator Over Voltage Alarm IEEE 37.2 – 59 AC Overvoltage Relay	Generator Over Volts gives a <i>Shutdown</i> alarm in the event of the generator output rising above the configured <i>Over Volts Alarm Trip</i> value for longer than the <i>Generator Transient Delay</i> . The <i>Over-volts Alarm Trip</i> value is adjustable to suit user requirements.

2.7.3 GENERATOR FREQUENCY

Under Frequency Alarms

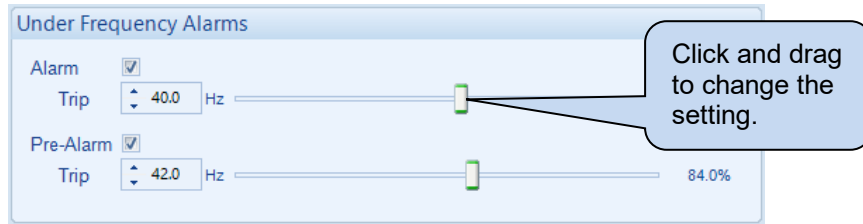

Parameter	Description
Generator Under Frequency Alarm <i>IEEE 37.2 -81 Frequency Relay</i>	<input type="checkbox"/> = Generator Under Frequency does NOT give an alarm <input checked="" type="checkbox"/> = Generator Under Frequency gives an alarm in the event of the generator output frequency falling below the configured <i>Under Frequency Alarm Trip</i> value for longer than the <i>Generator Transient Delay</i> . The <i>Under-frequency Alarm Trip</i> value is adjustable to suit user requirements.
Generator Under Frequency Pre-Alarm <i>IEEE 37.2 -81 Frequency Relay</i>	<input type="checkbox"/> = Generator Under Frequency does NOT give a warning alarm <input checked="" type="checkbox"/> = Generator Under Frequency gives a warning alarm in the event of the generator output frequency falling below the configured <i>Under Frequency Pre-Alarm Trip</i> value for longer than the <i>Generator Transient Delay</i> . The <i>Under Frequency Pre-Alarm Trip</i> value is adjustable to suit user requirements.

Loading Frequency

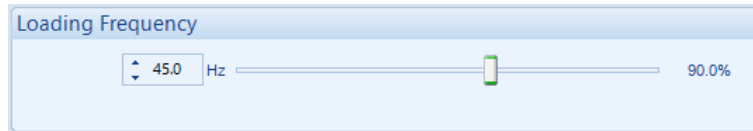

Parameter	Description
Loading Frequency	This is the minimum frequency the generator must be operating at, before the module considers it available to take the load. It is also the frequency above the under frequency trip that the generator output must return to before the module considers that the supply is back within limits. (i.e. With an under-frequency trip of 42.0 Hz and a loading frequency of 45.0 Hz, the output frequency must return to 45.0 Hz following an under frequency event to be considered within limits.)

Nominal Frequency

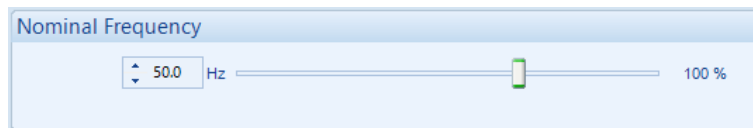

Parameter	Description
Nominal Frequency	This is used to calculate the percentages of the alarm and to instruct the ECU what speed to run the engine at.

Over Frequency Alarms

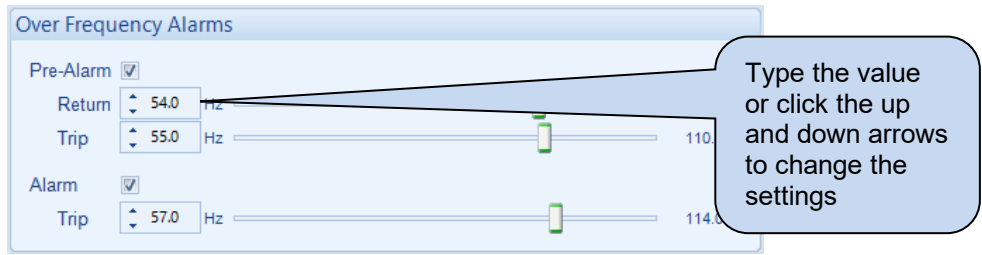

Parameter	Description
Generator Over Frequency Pre-Alarm IEEE 37.2 -81 Frequency Relay	<input type="checkbox"/> = Alarm is disabled <input checked="" type="checkbox"/> = Generator Over Frequency gives a warning alarm in the event of the generator output frequency rising above the configured <i>Over Frequency Pre-Alarm Trip</i> value for longer than the <i>Generator Transient Delay</i> . The <i>Warning</i> is automatically reset when the generator output frequency falls below the configured <i>Return</i> level. The <i>Over Frequency Pre-Alarm Trip</i> value is adjustable to suit user requirements.
Generator Over Frequency Alarm IEEE 37.2 -81 Frequency Relay	<input type="checkbox"/> = Alarm is disabled <input checked="" type="checkbox"/> = Generator Over Frequency gives a <i>Shutdown</i> alarm in the event of the generator output rising above the configured <i>Over Frequency Alarm Trip</i> value for longer than the <i>Generator Transient Delay</i> . The <i>Over Frequency Alarm Trip</i> value is adjustable to suit user requirements.

2.7.4 GENERATOR CURRENT

Generator Current Options

Parameter	Description
Enable CT Support	<input type="checkbox"/> = CTs are disabled, the module does not measure or display current readings. <input checked="" type="checkbox"/> = CTs are enabled, the module displays current readings.
CT Primary	Primary rating of the three phase Current Transformers
CT Secondary	Secondary rating of all the current transformers, options are: 1 Amp 5 Amp
Full Load Rating	This is the full load current rating of the alternator
CT Location	Gen: The CTs are in the feed from the generator, the module provides current instrumentation and protections when the generator is on load Load: The CTs are in the feed to the load, the module provides current instrumentation and protections when the generator is on load, and current instrumentation when the mains is on load.

Overcurrent Alarm

Parameter	Description
Immediate Warning IEEE 37.2 -50 Instantaneous Overcurrent Relay	<input type="checkbox"/> = <i>Immediate Overcurrent Warning</i> is disabled. <input checked="" type="checkbox"/> = The <i>Immediate Overcurrent Warning</i> activates as soon as the <i>Trip</i> level is reached. The alarm automatically resets once the generator loading current falls below the <i>Trip</i> level (unless <i>All Warnings are latched</i> is enabled). For further advice, consult the generator supplier.
Delayed Alarm IEEE 37.2 -51 AC Time Overcurrent Relay	<input type="checkbox"/> = <i>Delayed Overcurrent Alarm</i> is disabled. <input checked="" type="checkbox"/> = The <i>Delayed Overcurrent Alarm</i> activates when the current exceeds the <i>Trip</i> setting for longer than the configured <i>Delay</i> time.
Delayed Alarm Action	Select the type of alarm required from the list: Electrical Trip Shutdown Warning For details of these, see the section entitled <i>Alarm Types</i> elsewhere in this document.

Generator Rating

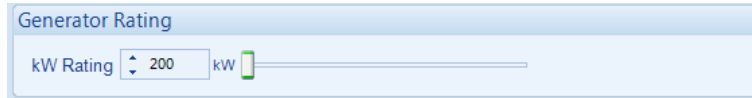

Parameter	Description
kW Rating	The kW rating of the generator. This is used for the <i>Overload Protection</i> .

Overload Protection

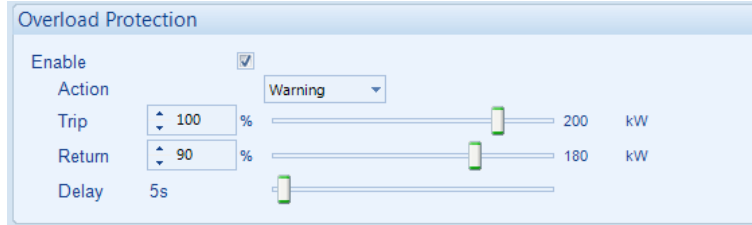

Parameter	Description
Enable	<p>⚠ NOTE: The <i>Return</i> level is only used when <i>Warning</i> action is selected, to silence the Warning alarm when the kW level drops below the configured <i>Return</i> level.</p> <p><input type="checkbox"/> = Overload Protection function is disabled. <input checked="" type="checkbox"/> = <i>kW Overload Alarm</i> activated when the kW level exceeds the <i>Trip</i> level for the configured <i>Delay</i> time.</p>
Action	Select the type of alarm required from the list: <i>Electrical Trip</i> <i>Shutdown</i> <i>Warning</i>
Trip	Set the percentage of total kW load at which the <i>Overload Alarm</i> is activated
Return	<p>⚠ NOTE: Only applicable for the <i>Warning</i>.</p> <p>Set the percentage of total kW load at which the <i>Overload Warning Alarm</i> is de-activated when the kW load drops below.</p>
Delay	The amount of time before the module activates the <i>Overload Alarm</i> .

2.8 MAINS



= Only available on DSE4520 MKII AMF modules

The *Mains* section is subdivided into smaller sections. Select the required section with the mouse.

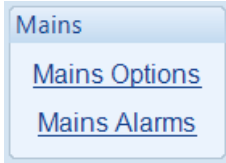

2.8.1 MAINS OPTIONS

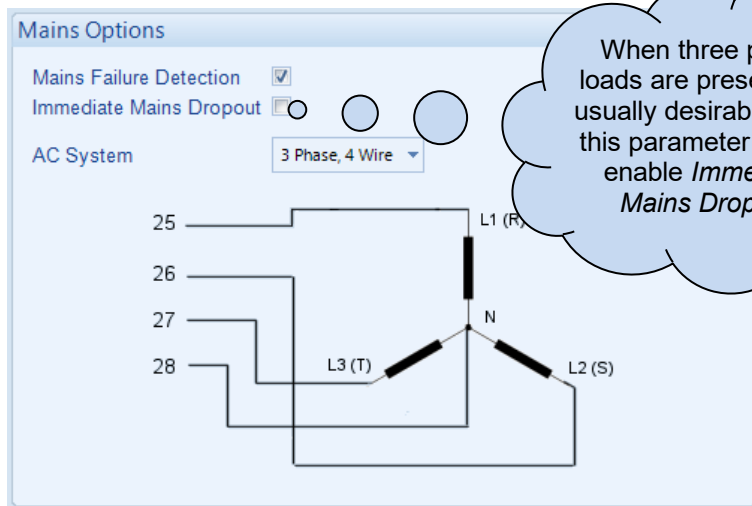

When three phase loads are present, it is usually desirable to set this parameter to to enable *Immediate Mains Dropout*.

Parameter	Description
Mains Failure Detection 	<input type="checkbox"/> = The module ignores the status of the mains supply. <input checked="" type="checkbox"/> = The module monitors the mains supply and use this status for automatically starting and stopping the set in auto mode.
Immediate Mains Dropout 	<input type="checkbox"/> = Upon mains failure, the mains load switch is kept closed until the generator is up to speed and volts. <input checked="" type="checkbox"/> = Upon mains failure, the mains load switch is opened immediately, subject to the setting of the <i>mains transient</i> timer.
AC System 	Select the AC topology of the generator from the following list: 2 Phase, 3 Wire L1 - L2 2 Phase, 3 Wire L1 - L3 3 Phase, 3 Wire 3 Phase, 4 Wire 3 Phase, 4 Wire Delta Single Phase, 2 Wire

2.8.2 MAINS ALARMS

Under Voltage Alarms

Under Voltage Alarms

Alarm

Trip V PhPh 318V PhPh

Return V PhPh 329V PhPh

Pre-Alarm

Trip V PhPh 339V PhPh

Return V PhPh 358V PhPh

Parameter	Description
Mains Under Voltage IEEE 37.2 – 27 AC Undervoltage Relay 	<input type="checkbox"/> = Mains Under Voltage detection is disabled <input checked="" type="checkbox"/> = Mains Under Voltage gives an alarm in the event of the mains voltage falling below the configured <i>Under Voltage Trip</i> value. The <i>Under Voltage Trip</i> value is adjustable to suit the application. The alarm is reset and the mains is considered within limits when the mains voltage rises above the configured <i>Under Voltage Return</i> level.
Mains Over Voltage IEEE 37.2 – 59 AC Overvoltage Relay 	<input type="checkbox"/> = Mains Over Voltage detection is disabled <input checked="" type="checkbox"/> = Mains Over Voltage gives an alarm in the event of the mains voltage rising above the configured <i>Over Voltage Trip</i> value. The <i>Over Voltage Trip</i> value is adjustable to suit the application. The alarm is reset and the mains is considered within limits when the mains voltage falls below the configured <i>Over Voltage Return</i> level.

Over Voltage Alarms

Over Voltage Alarms

Pre-Alarm

Return V PhPh 439V PhPh

Trip V PhPh 458V PhPh

Alarm

Return V PhPh 467V PhPh

Trip V PhPh 479V PhPh

Parameter	Description
Mains Under Frequency IEEE 37.2 – 81 Frequency Relay 	<input type="checkbox"/> = Mains Under Frequency detection is disabled <input checked="" type="checkbox"/> = Mains Under Frequency gives an alarm in the event of the mains frequency falling below the configured <i>Under Frequency Trip</i> value. The <i>Under Frequency Trip</i> value is adjustable to suit the application. The alarm is reset and the mains is considered within limits when the mains frequency rises above the configured <i>Under Frequency Return</i> level.
Mains Over Frequency IEEE 37.2 – 81 Frequency Relay 	<input type="checkbox"/> = Mains Over Frequency detection is disabled <input checked="" type="checkbox"/> = Mains Over Frequency gives an alarm in the event of the mains frequency rising above the configured <i>Over Frequency Trip</i> value. The <i>Over Frequency Trip</i> value is adjustable to suit the application. The alarm is reset and the mains is considered within limits when the mains frequency falls below the configured <i>Over Frequency Return</i> level.

2.9 ENGINE

The *Engine* section is subdivided into smaller sections. Select the required section with the mouse.



2.9.1 ENGINE PROTECTION

Water in Fuel

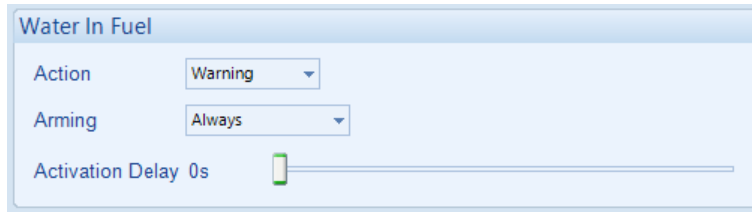

Parameter	Description
Water in Fuel	Select the type of action when the <i>Water In Fuel</i> alarm occurs, after the <i>Activation Delay time</i> . Options are: None Electrical Trip Shutdown Warning
Arming	Select when the <i>Water In Fuel</i> alarm becomes active: Always: The <i>Water In Fuel</i> alarm state is always monitored From Safety On: The alarm is monitored from the end of the <i>Safety On Delay</i> timer From Starting: The alarm is only monitored from engaging the crank Never: The alarm is disabled When Stationary: The alarm is only monitored when the engine is not running

Fuel Tank Bund

Parameter	Description
Fuel Tank Bund	Select the type of action when the <i>Fuel Tank Bund</i> alarm occurs. Options are: Electrical Trip Shutdown Warning

Fan Speed Low

Parameter	Description
Fan Speed Low	Select the type of action when the <i>Fan Speed Low</i> alarm occurs, after the <i>Activation Delay time</i> . Options are: Electrical Trip Shutdown Warning
Arming	Select when the <i>Water In Fuel</i> alarm becomes active: Always: The <i>Water In Fuel</i> alarm state is always monitored From Safety On: The alarm is monitored from the end of the <i>Safety On Delay</i> timer From Starting: The alarm is only monitored from engaging the crank Never: The alarm is disabled

2.9.2 OIL PRESSURE

NOTE: The DSE module reads oil pressure from the ECU (ECM) if the selected Engine Application supports it. In these cases, Analogue Input A is configured as Flexible Analogue or Digital Input. Configuration of Flexible Analogue Inputs and Digital Inputs is detailed elsewhere in this document.

Input Type

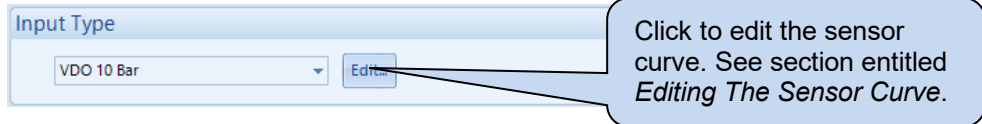

Parameter	Description
Input Type	Select the sensor type and curve from a pre-defined list or create a user-defined curve Resistive: for sensors with maximum range of 0 Ω to 480 Ω Current: for sensors with maximum range of 0 mA to 20 mA Voltage: for sensors with maximum range of 0 V to 10 V

Sensor Open Circuit Alarm

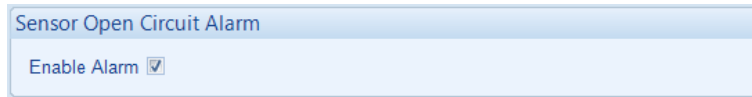

Parameter	Description
Enable Alarm	<input type="checkbox"/> = Alarm is disabled. <input checked="" type="checkbox"/> = The <i>Low Oil Pressure Open Circuit Alarm</i> is active when the module detects an open circuit when the sensor is disconnected

Low Oil Pressure Alarms

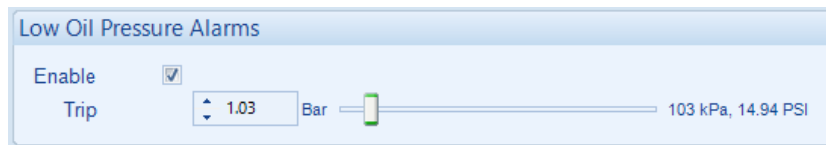

Parameter	Description
Low Oil Pressure Alarms	<input type="checkbox"/> = Alarm is disabled. <input checked="" type="checkbox"/> = The <i>Low Oil Pressure Shutdown Alarm</i> is active when the measured oil pressure drops below the configured <i>Trip</i> level.

2.9.3 ENGINE COOLANT

The *Coolant Temperature* section is subdivided into smaller sections. Select the required section with the mouse.

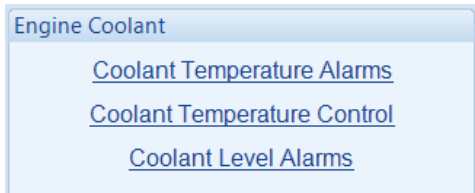

2.9.3.1 COOLANT TEMPERATURE ALARMS

NOTE: The DSE module reads oil pressure from the ECU (ECM) if the selected Engine Application supports it. In these cases, Analogue Input B is configured as Flexible Analogue or Digital Input. Configuration of Flexible Analogue Inputs and Digital Inputs is detailed elsewhere in this document.

Input Type



Parameter	Description
Input Type	Select the sensor type and curve from a pre-defined list or create a user-defined curve Resistive: for sensors with maximum range of 0 Ω to 480 Ω Current: for sensors with maximum range of 0 mA to 20 mA Voltage: for sensors with maximum range of 0 V to 10 V

Sensor Open Circuit Alarm

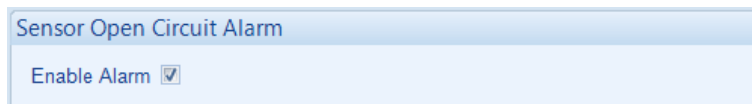

Parameter	Description
Enable Alarm	<input type="checkbox"/> = Alarm is disabled. <input checked="" type="checkbox"/> = The <i>Coolant Temperature Open Circuit Alarm</i> is active when the module detects an open circuit when the sensor is disconnected

High Coolant Temperature Alarms

The screenshot shows a configuration window titled "High Coolant Temperature Alarms". It contains the following elements:

- Pre-Alarm:** A checkbox that is checked.
- Return:** A numeric input field set to 88 °C, with a corresponding slider and a label of 190 °F.
- Trip:** A numeric input field set to 90 °C, with a corresponding slider and a label of 194 °F.
- Shutdown Trip:** A numeric input field set to 96 °C, with a corresponding slider and a label of 205 °F.

Parameter	Description
High Coolant Temperature Pre-Alarm	<input type="checkbox"/> = Alarm is disabled. <input checked="" type="checkbox"/> = The High Coolant Temperature Warning Alarm is active when the measured coolant temperature rises above the configured Trip level. The Warning is automatically reset when the coolant temperature falls below the configured Return level.
High Coolant Temperature Shutdown	The High Coolant Temperature Shutdown Alarm is active when the measured coolant temperature rises above the configured Trip level.

2.9.3.2 COOLANT TEMPERATURE CONTROL

Coolant Heater Control

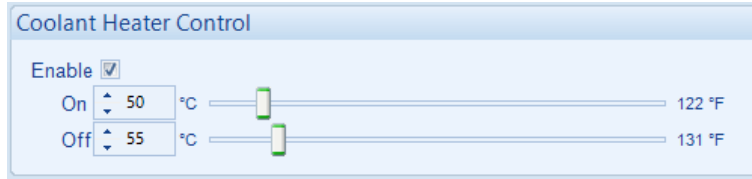

Parameter	Description
Coolant Heater Control	<input type="checkbox"/> = Coolant Heater Control function is disabled <input checked="" type="checkbox"/> = The digital output configured to <i>Coolant Heater Control</i> is energised when the engine coolant temperature falls below the configured <i>On</i> level. This is designed to control an external engine heater. When the coolant temperature rises above the configured <i>Off</i> level, the digital output is de-energised.

Coolant Cooler Control

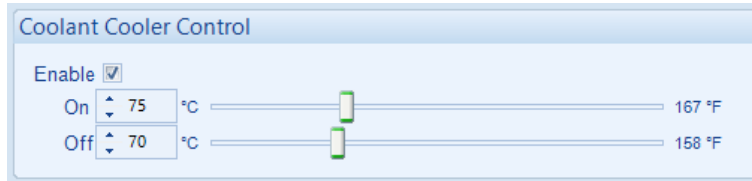

Parameter	Description
Coolant Cooler Control Enable	<input type="checkbox"/> = Coolant Cooler Control function is disabled <input checked="" type="checkbox"/> = The digital output configured to <i>Coolant Cooler Control</i> is energised when the engine coolant temperature exceeds the configured <i>On</i> level. This is designed to control an external engine cooling system, for instance an additional cooling fan. When the coolant temperature falls below the configured <i>Off</i> level, the digital output is then de-energised.

2.9.3.3 COOLANT LEVEL ALARMS

Input Type



Parameter	Description
Input Type	Select the sender curve from a pre-defined list or create a user-defined curve.

Sensor Open Circuit

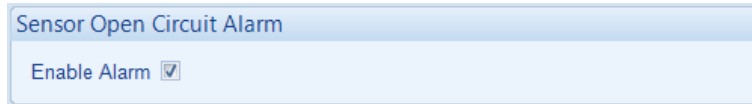

Parameter	Description
Sensor Open Circuit Alarm	<input type="checkbox"/> = Alarm is disabled. <input checked="" type="checkbox"/> = The <i>Low Coolant Sensor Open Circuit Alarm</i> is active when the module detects an open circuit when the sender is disconnected

Coolant Level Alarms

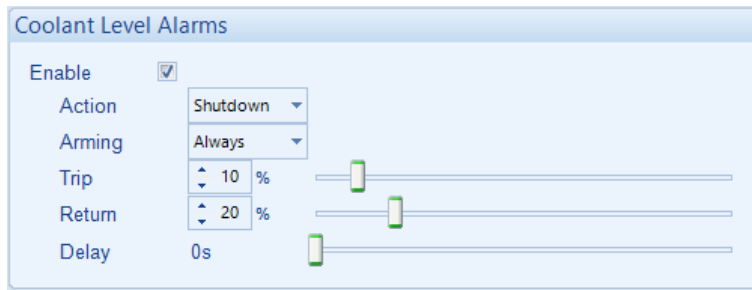

Parameter	Description
Enable	<p>NOTE: The <i>Return</i> level is only used when <i>Warning</i> action is selected, to silence the <i>Warning</i> alarm when the coolant level rises above the configured <i>Return</i> level.</p> <p><input type="checkbox"/> = Low Coolant Level alarm is disabled. <input checked="" type="checkbox"/> = Low Coolant Level alarm activated when the level falls below the <i>Trip</i> level for the configured <i>Delay</i> time.</p>
Action	<p>NOTE: For details of these, see the section entitled <i>Alarm Types</i> elsewhere in this document.</p> <p>Select the type of alarm required from the list: Electrical Trip Shutdown Warning</p>

Parameter descriptions continued overleaf...

Parameter	Description
Arming	<p>NOTE: For details of these, see the section entitled <i>Alarm Arming</i> elsewhere in this document.</p> <p>Select when the alarm generated by the input becomes active: Always From Safety On From Starting</p>
Trip	Set the percentage which the <i>Low Coolant Level Alarm</i> is activated
Return	<p>NOTE: Only applicable for the <i>Warning</i>.</p> <p>Set the percentage at which the <i>Low Coolant Level Alarm</i> is de-activated</p>
Delay	The amount of time before the module activates the alarm

Coolant Level Switch

NOTE: This function requires a digital input to be configured as *Low Coolant Level Switch*.

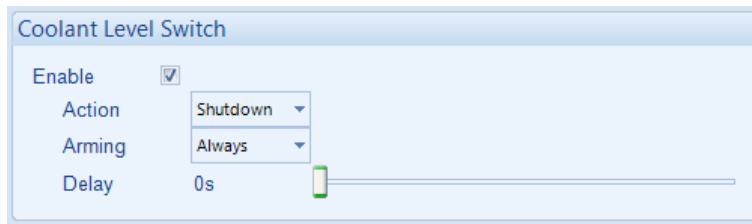

Parameter	Description
Enable	<p><input type="checkbox"/> = Alarm is disabled. <input checked="" type="checkbox"/> = The DSE module monitors the state of the <i>Low Coolant Level Switch</i> input to activate the alarm.</p>
Action	<p>NOTE: For details of these, see the section entitled <i>Alarm Types</i> elsewhere in this document.</p> <p>Select the type of alarm required from the list: Electrical Trip Shutdown Warning</p>
Arming	<p>NOTE: For details of these, see the section entitled <i>Alarm Arming</i> elsewhere in this document.</p> <p>Select when the alarm generated by the input becomes active: Always From Safety On From Starting</p>
Delay	The amount of time before the module activates the alarm

2.9.4 FUEL OPTIONS

The *Fuel Level* section is subdivided into smaller sections. Select the required section with the mouse.



2.9.4.1 FUEL LEVEL

Input Type

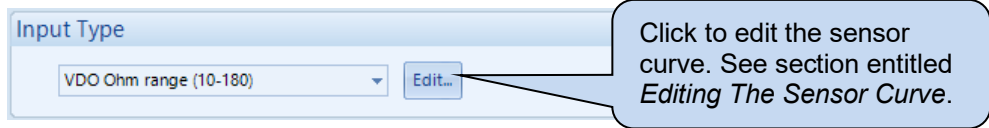

Parameter	Description
Input Type	Select the sensor type and curve from a pre-defined list or create a user-defined curve Resistive: for sensors with maximum range of 0 Ω to 480 Ω Current: for sensors with maximum range of 0 mA to 20 mA Voltage: for sensors with maximum range of 0 V to 10 V

In the case of a parallel sided fuel tank, an accurate measure of the fuel level is easily made, however this is not the case with non-parallel sided fuel tanks. Alteration to the fuel level sensor curve is required for non-parallel sided to attain more accurate level indication. This is because a fuel level sensor measures the distance between the top of the tank and the fuel level.

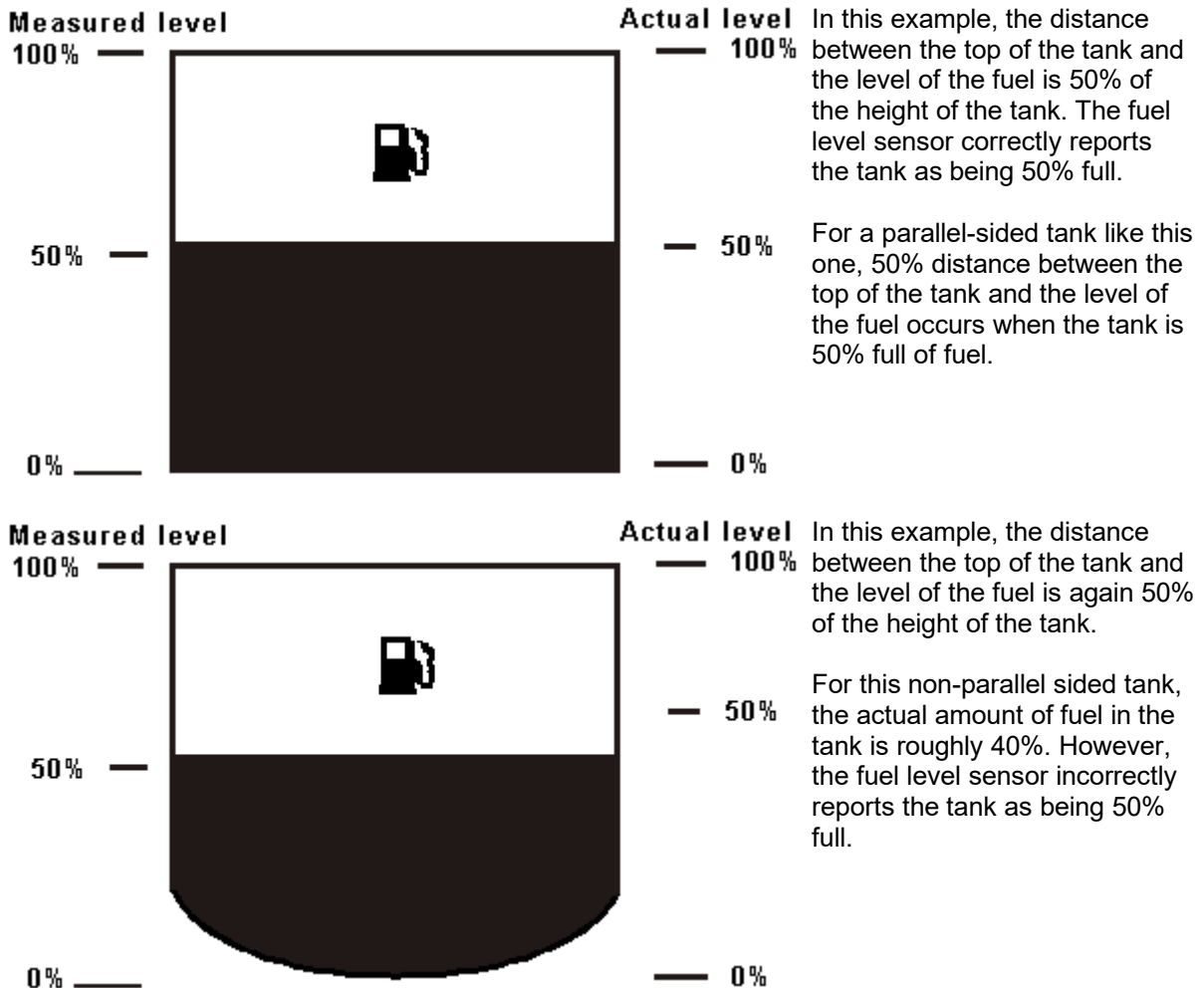

Low Fuel Level Alarms

Parameter	Description
Low Fuel Level Alarm	<input type="checkbox"/> = Alarm is disabled. <input checked="" type="checkbox"/> = The <i>Low Fuel Level Alarm</i> activates with the configured <i>Action</i> when the measured fuel level drops below the <i>Trip</i> setting for the configured <i>Delay</i> time.
Action	<div style="border: 1px solid black; padding: 5px;"> <p>⚠ NOTE: For details of these, see the section entitled <i>Alarm Types</i> elsewhere in this document.</p> </div> <p>Select the type of alarm required from the list: <i>Electrical Trip</i> <i>Shutdown</i></p>
Low Fuel Level Pre-Alarm	<input type="checkbox"/> = Alarm is disabled. <input checked="" type="checkbox"/> = The <i>Low Fuel Level Pre-Alarm</i> activates with the configured <i>Action</i> when the measured fuel level drops below the <i>Low Pre-Alarm Trip</i> setting for the configured <i>Delay</i> time. The pre-alarm is automatically reset when the fuel level exceeds the configured <i>Low Pre-Alarm Return</i> setting.

High Fuel Level Alarms

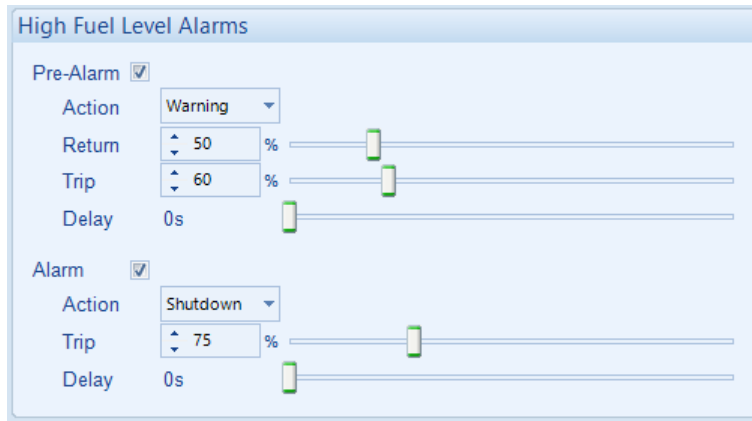

Parameter	Description
High Fuel Level Pre-Alarm	<input type="checkbox"/> = Alarm is disabled. <input checked="" type="checkbox"/> = The <i>High Fuel Level Pre-Alarm</i> activates with the configured <i>Action</i> when the measured fuel level rises above the <i>High Pre-Alarm Trip</i> setting for the configured <i>Delay</i> time. The pre-alarm is automatically reset when the fuel level drops below the configured <i>High Pre-Alarm Return</i> setting.
High Fuel Level Alarm	<input type="checkbox"/> = Alarm is disabled. <input checked="" type="checkbox"/> = The <i>High Fuel Level Alarm</i> activates with the configured <i>Action</i> when the measured fuel level raises above the <i>Trip</i> setting for the configured <i>Delay</i> time.
Action	<div style="border: 2px solid black; padding: 5px;"> <p>⚠ NOTE: For details of these, see the section entitled <i>Alarm Types</i> elsewhere in this document.</p> </div> <p>Select the type of alarm required from the list: <i>Electrical Trip</i> <i>Shutdown</i></p>

Fuel Level Switch

▲ NOTE: This function requires a digital input to be configured as *Low Fuel Level Switch*.

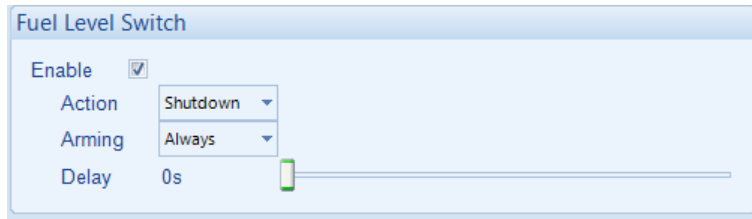

Parameter	Description
Fuel Level Switch Enable	<input type="checkbox"/> = Alarm is disabled. <input checked="" type="checkbox"/> = The DSE module monitors the state of the <i>Low Fuel Level Switch</i> input to activate the alarm.
Action	<div style="border: 1px solid black; padding: 5px;"> <p>▲ NOTE: For details of these, see the section entitled <i>Alarm Types</i> elsewhere in this document.</p> </div> <p>Select the type of alarm required from the list: Electrical Trip Shutdown Warning</p>
Arming	<div style="border: 1px solid black; padding: 5px;"> <p>▲ NOTE: For details of these, see the section entitled <i>Alarm Arming</i> elsewhere in this document.</p> </div> <p>Select when the alarm generated by the input becomes active: Always From Safety On From Starting</p>
Delay	The amount of time before the module activates the alarm

2.9.4.2 FUEL USAGE ALARM

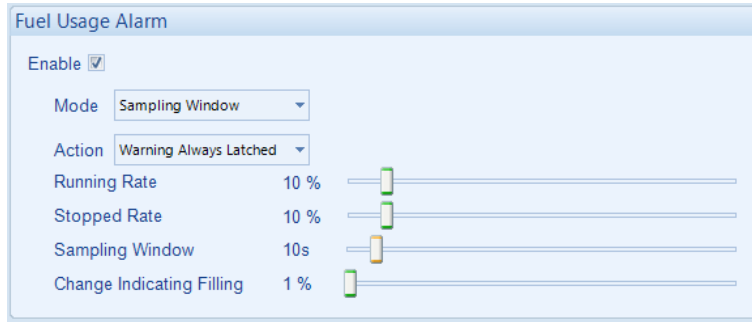

Parameter	Description
Fuel Usage Alarm Enable	<input type="checkbox"/> = Alarm is disabled. <input checked="" type="checkbox"/> = Provides an alarm to monitor the usage of the fuel. The alarm activates when the fuel level drops at a higher rate than the configured <i>Running Rate</i> while the engine is running. Or if the fuel level drops at a higher rate than the configured <i>Stopped Rate</i> while the engine is stopped. This alarm is provided to check for fuel leakage problems or potential fuel theft.
Mode	<i>Sampling Window:</i> The fuel usage alarm activates when the fuel level decreases at a higher rate per <i>Sampling Window</i> than the configured <i>Running Rate</i> while the engine is running, or <i>Stopped Rate</i> while the engine is stopped. <i>Standard Mode:</i> The fuel usage alarm activates when the fuel level decreases at a higher rate per hour than the configured <i>Running Rate</i> while the engine is running, or <i>Stopped Rate</i> while the engine is stopped.
Action	The alarm action list is as follows, see section entitled <i>Alarm Types</i> for more information: <i>Electrical Trip</i> <i>Latched Indication</i> <i>Shutdown</i> <i>Warning Always Latched</i>
Change Indicating Filling	An increase in fuel level above this setting is logged as a <i>Fuel Fill</i> event.

2.9.5 ENGINE OPTIONS

ECU (ECM) Options

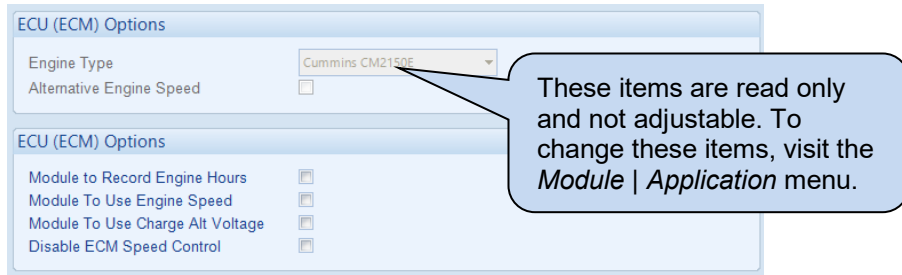

Parameter	Description
Module To Record Engine Hours	<input type="checkbox"/> = <i>Engine Run Time</i> is provided by the ECU <input checked="" type="checkbox"/> = The DSE module counts the <i>Engine Run Time</i>
Module To Use Engine Speed	<input type="checkbox"/> = <i>Engine Speed</i> is provided by the ECU <input checked="" type="checkbox"/> = The DSE module measures the <i>Engine Speed</i>
Module To Use Charge Alt Voltage	<input type="checkbox"/> = <i>Engine Run Time</i> is provided by the ECU <input checked="" type="checkbox"/> = The DSE module counts the <i>Engine Run Time</i>
Disable ECM Speed	<input type="checkbox"/> = <i>Engine Speed</i> is controlled by the ECU, this disables the command from the DSE module to run at nominal speed <input checked="" type="checkbox"/> = The DSE module commands the ECU to run the engine at the configured speed

Miscellaneous Options

NOTE: For a full list of the J1939-75 alarms and instrumentation, refer to DSE Publication: *057-260 DSE4510 MKII & DSE4520 MKII Operator Manual* found on DSE's website: www.deepseaelectronics.com

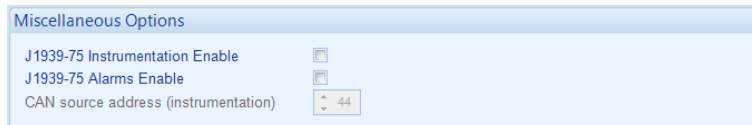

Parameter	Description
J1939-75 Instrumentation Enable	<input type="checkbox"/> = J1939-75 Instrumentation is not broadcast by the DSE module. <input checked="" type="checkbox"/> = J1939-75 Instrumentation is broadcast by the DSE module.
J1939-75 Alarms Enable	<input type="checkbox"/> = J1939-75 Alarms are not broadcast by the DSE module. <input checked="" type="checkbox"/> = J1939-75 Alarms are broadcast by the DSE module.
CAN Source Address (Instrumentation)	Set the <i>CAN Source Address</i> for the DSE module over which other CANbus devices read the generator set instrumentation.

Startup Options

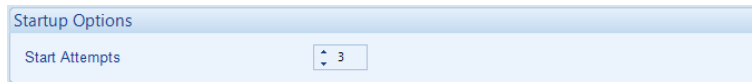

Parameter	Description
Start Attempts	<p>The number of starting attempts the module makes.</p> <p>If the module does not detect that the engine has fired before the end of the <i>Cranking Time</i>, then the current start attempt is cancelled and the <i>Crank Rest</i> time takes place before the next crank attempt begins.</p> <p>If, after all configured <i>start attempts</i>, the engine is not detected as running, the <i>Fail to Start</i> shutdown alarm is generated.</p> <p>The engine is detected as running by checking all methods of <i>Crank Disconnect</i>. For further details, see the section entitled <i>Crank Disconnect</i> elsewhere in this document.</p>

Pre-heat

NOTE: For this feature to have effect, configure a digital output for *Pre-Heat*.

NOTE: Depending on *Engine Type* configuration, this is controlled direct by the ECU (ECM).

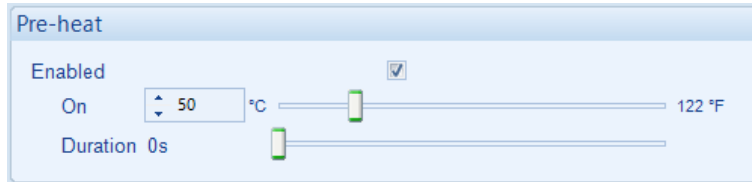

Parameter	Description
Enabled	<p><input type="checkbox"/> = Pre-heat is not temperature dependent.</p> <p><input checked="" type="checkbox"/> = When the <i>Coolant Temperature</i> is below the configured <i>On</i> level, the <i>Pre-Heat</i> digital output is activated for the set <i>Duration</i> of time before cranking.</p>
On	Set the coolant temperature below which the pre-heat is activated.
Duration	Set the time delay during which the <i>Pre-Heat</i> digital output remains active before cranking

Post-heat

NOTE: For this feature to have effect, configure a digital output for *Pre-Heat*.

NOTE: Depending on *Engine Type* configuration, this is controlled direct by the ECU (ECM).

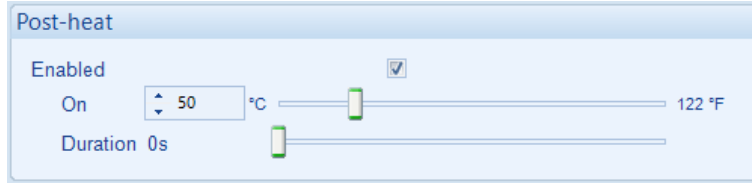

Parameter	Description
Enabled	<input type="checkbox"/> = Post-heat is not temperature dependent. <input checked="" type="checkbox"/> = When the <i>Coolant Temperature</i> is below the configured <i>On</i> level, the <i>Pre-Heat</i> digital output is activated for the set <i>Duration</i> of time after cranking and before the set is considered available.
On	Set the coolant temperature below which the pre-heat is activated.
Duration	Set the time delay during which the <i>Pre-Heat</i> digital output remains active after cranking and before the engine is considered available.

Overspeed Options

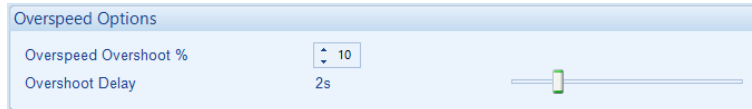

Parameter	Description
Overspeed Overshoot %	To prevent spurious overspeed alarms at engine start up, the module includes configurable <i>Overspeed Overshoot</i> protection. This allows the engine speed to 'overshoot' the Overspeed setting during the starting process for a short time.
Overshoot Delay	Rather than 'inhibiting' the Overspeed alarms, the levels are temporarily raised by the <i>Overspeed Overshoot %</i> for the duration of the <i>Overspeed Overshoot</i> delay from starting.

2.9.6 ECU (ECM) OPTIONS

DPF Regeneration Control

Parameter	Description
DPF Regeneration Control	Available for ECUs (ECM) which require the engine speed to drop during a manual regeneration cycle. During this time, the generator is not available to supply power and the under speed and under frequency alarms are not active.

ECU Wakeup

Parameter	Description
ECU Wakeup Enable	<input type="checkbox"/> = Option is disabled. <input checked="" type="checkbox"/> = When the engine is stopped, the DSE module sends a wakeup signal to the ECU (ECM) and keeps it powered up for the <i>ECU Override</i> time (configured in <i>Start Timers</i>) to read the ECU (ECM) parameters. This is periodically repeated depending on the configured <i>Periodic Wakeup Time</i> .
Coolant Measurement Persistence	<div style="border: 2px solid black; padding: 5px; text-align: center;"> NOTE: Available only when <i>ECU Wakeup</i> is enabled. </div> <input type="checkbox"/> = Option is disabled. <input checked="" type="checkbox"/> = The <i>Coolant Temperature</i> measurement is used for the <i>Coolant Temperature Control</i> .

SPN Ignore List

Parameter	Description
SPN Ignore List	Choose the specific SPN for the module to ignore. The module allows the engine to keep running when the ignored SPN occurs; however, depending on the severity, the engine shuts down based on the ECU (ECM) calibration. This is used to mask certain indications or warnings on the ECU (ECM) and not display them on the DSE module.

Miscellaneous

Miscellaneous

CAN source address (engine messages)

Parameter	Description
CAN Source Address (Engine Messages)	<p>NOTE: Although automatically pre-set upon selection of the Engine Type, this parameter is available for change if required.</p> <p>Set the <i>CAN Source Address</i> that the module is to read instrumentation from. This is typically the Source Address of the engine ECU.</p>

2.9.7 ECU (ECM) ALARMS

NOTE: This section is only available when the module is connected to an ECU.

The *ECU (ECM) Alarms* section is subdivided into smaller sections. Select the required section with the mouse.

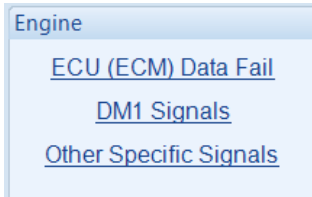

2.9.7.1 ECU (ECM) DATA FAIL

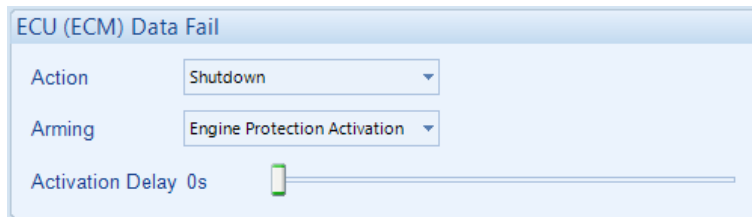

Parameter	Description
ECU (ECM) Data Fail Action	Provides protection against failure of the ECU (ECM) CAN data link. The alarm action list is as follows, see section entitled <i>Alarm Types</i> for more information: None Shutdown Warning
Arming	Select when the <i>CAN ECU (ECM) Data Fail</i> alarm is active. Options are as follows, see the section entitled <i>Alarm Arming</i> elsewhere in this document: Engine Protection Activation From Safety On From Starting
Activation Delay	The amount of time before the module activates the <i>CAN ECU (ECM) Data Fail</i> after a failure.

2.9.7.2 DM1 SIGNALS

NOTE: Configuration of parameters in this section only has effect when the ECU (ECM) supports these features.

NOTE: Configuration of the *Alarm Action* in this section defines the DSE module response to the CAN message; however, the ECU (ECM) still shuts down the engine depending on the alarm severity.

DM1 signals are messages from the CAN (ECM) ECU. The following parameters allows configuration of how the DSE module responds to these messages.

ECU Amber

The screenshot shows a configuration window titled "ECU Amber". It contains three settings:

- Action:** A dropdown menu currently set to "Warning".
- Arming:** A dropdown menu currently set to "Always".
- Activation Delay:** A slider control set to "0s".

Parameter	Description
ECU Amber Action	The action the DSE module takes when receiving and ECU Amber fault condition. The alarm action list is as follows, see section entitled <i>Alarm Types</i> for more information: None Electrical Trip Shutdown Warning
Arming	Select when the DSE module activates it <i>ECU Amber</i> alarm. Options are as follows, see the section entitled <i>Alarm Arming</i> elsewhere in this document: Always From Safety On From Starting Never
Activation Delay	The amount of time before the module activates the <i>ECU Amber</i> alarm after a receiving an ECU Amber fault condition from the ECU.

ECU Red

The screenshot shows a configuration window titled "ECU Red". It contains three settings:

- Action:** A dropdown menu currently showing "Shutdown".
- Arming:** A dropdown menu currently showing "From Safety On".
- Activation Delay:** A slider control set to "0s".

Parameter	Description
ECU Red Action	The action the DSE module takes when receiving an ECU Red fault condition. The alarm action list is as follows, see section entitled <i>Alarm Types</i> for more information: None Electrical Trip Shutdown Warning
Arming	Select when the DSE module activates its <i>ECU Red</i> alarm. Options are as follows, see the section entitled <i>Alarm Arming</i> elsewhere in this document: Always From Safety On From Starting Never
Activation Delay	The amount of time before the module activates the <i>ECU Red</i> alarm after receiving an ECU Red fault condition from the ECU.

2.9.7.3 OTHER SPECIFIC SIGNALS

DPTC Filter

Parameter	Description
DPTC Filter Enabled	<p><input type="checkbox"/> = The DSE module's <i>DPTC Filter</i> alarm is disabled, it does not act upon any DPTC Filter fault conditions from the ECU.</p> <p><input checked="" type="checkbox"/> = The DSE module's <i>DPTC Filter</i> alarm is enabled. The action the DSE module takes when receiving a DPTC Filter fault condition from the ECU. The alarm action list is as follows, see section entitled <i>Alarm Types</i> The alarm action list is as follows, see section entitled <i>Alarm Types</i> for more information:</p> <p>Electrical Trip Indication Shutdown Warning</p>
Arming	<p>Select when the DSE module activates its <i>DPTC Filter</i> alarm. Options are as follows, see the section entitled <i>Alarm Arming</i> elsewhere in this document:</p> <p>Always From Safety On From Starting</p>

HEST Active

Parameter	Description
HEST Active Enabled	<p><input type="checkbox"/> = The DSE module's <i>HEST</i> alarm is disabled, it does not act upon any HEST fault conditions from the ECU.</p> <p><input checked="" type="checkbox"/> = The DSE module's <i>HEST</i> alarm is enabled. The action the DSE module takes when receiving a HEST fault condition from the ECU. The alarm action list is as follows, see section entitled <i>Alarm Types</i> The alarm action list is as follows, see section entitled <i>Alarm Types</i> for more information:</p> <p>Indication Warning</p>
Arming	<p>Select when the DSE module activates its <i>HEST</i> alarm. Options are as follows, see the section entitled <i>Alarm Arming</i> elsewhere in this document:</p> <p>Always From Safety On From Starting</p>

Parameter descriptions are continued overleaf...

DEF Level

Parameter	Description
DEF Level Enabled	<p><input type="checkbox"/> = The DSE module's <i>DEF Level</i> alarm is disabled, it does not act upon any DEF Level fault conditions from the ECU.</p> <p><input checked="" type="checkbox"/> = The DSE module's <i>DEF Level</i> alarm is enabled. The action the DSE module takes when receiving a DEF Level fault condition from the ECU. The alarm action list is as follows, see section entitled <i>Alarm Types</i> The alarm action list is as follows, see section entitled <i>Alarm Types</i> for more information:</p> <p>Electrical Trip Shutdown Warning</p>
Arming	<p>Select when the DSE module activates its <i>DEF Level</i> alarm. Options are as follows, see the section entitled <i>Alarm Arming</i> elsewhere in this document:</p> <p>Always From Safety On From Starting Loading Alarms Activation Never: When Stationary</p>
Activation Delay	<p>The amount of time before the module activates the <i>DEF Level</i> alarm after a receiving a DEF Level fault condition from the ECU.</p>

SCR Inducement



Parameter	Description
SCR Inducement Enabled	<p><input type="checkbox"/> = The DSE module's <i>SCR Inducement</i> alarm is disabled, it does not act upon any SCR Inducement fault conditions from the ECU.</p> <p><input checked="" type="checkbox"/> = The DSE module's <i>SCR Inducement</i> alarm is enabled. The action the DSE module takes when receiving a SCR Inducement fault condition from the ECU.</p> <p>The alarm action list is as follows, see section entitled <i>Alarm Types</i> The alarm action list is as follows, see section entitled <i>Alarm Types</i> for more information:</p> <p>Electrical Trip Shutdown Warning</p>
Arming	<p>Select when the DSE module activates its <i>SCR Inducement</i> alarm. Options are as follows, see the section entitled <i>Alarm Arming</i> elsewhere in this document:</p> <p>Always From Safety On From Starting Loading Alarms Activation Never: When Stationary</p>
Activation Delay	<p>The amount of time before the module activates the <i>SCR Inducement</i> alarm after a receiving a SCR Inducement fault condition from the ECU.</p>

2.9.8 GAS ENGINE OPTIONS

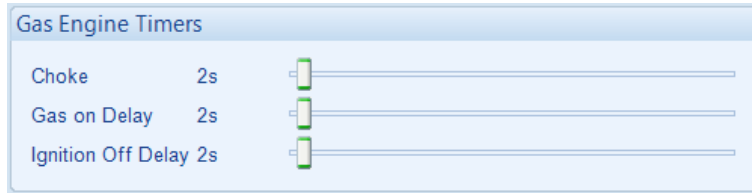

Parameter	Description
Choke Timer	Controls the amount of time that the Gas Choke output is active during the starting sequence.
Gas On Delay	Controls the amount of time between energising the Gas Ignition and energising the Fuel output. Used in the starting sequence to purge old gas from the engine.
Ignition Off Delay	Controls the amount of time between de-energising the Fuel output and de-energising the Gas Ignition output. Used in the stopping sequence to purge unburnt gas from the engine before it is stopped.

2.9.9 CRANK DISCONNECT

Cranking settings are used to detect when the set fires during the starting sequence. As the set is cranked, the first parameter that passes it's *crank disconnect* setting results in the cessation of the cranking signal.

Having more than one *crank disconnect* source allows for a much faster crank disconnect response leading to less wear on the engine and starter components, and provides added safety in case one source is lost, by a blown or tripped fuse for example.

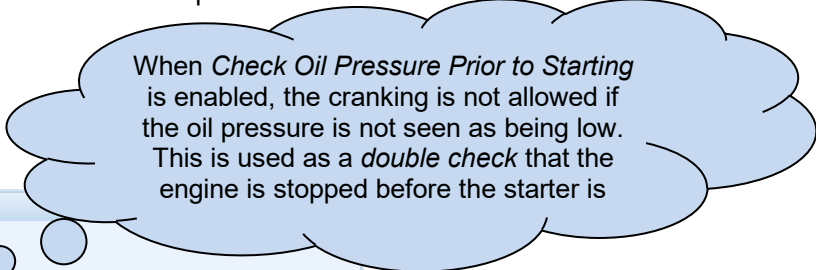

Options



Parameter	Description
Crank Disconnect on Oil Pressure	<input type="checkbox"/> = The DSE module does not use oil pressure to decide when to disengage the starter motor. <input checked="" type="checkbox"/> = The DSE module does uses oil pressure to decide when to disengage the starter motor in addition to the enabled methods
Check Oil Pressure Prior to Starting	<input type="checkbox"/> = The DSE module does not use oil pressure as an indication if the engine is running. This is disabled for large engines that have an electrical oil pump which is used to maintain oil pressure even when the engine is stationary. <input checked="" type="checkbox"/> = The DSE module uses oil pressure as an indication if the engine is running.

Crank Disconnect

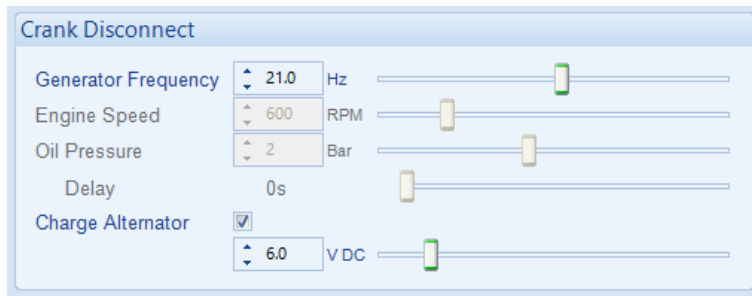

Parameter	Description
Generator Frequency	The DSE module disengages the starter motor when the generator frequency rises above the configured level.
Engine Speed	The DSE module disengages the starter motor when the engine speed rises above the configured level.
Oil Pressure	The DSE module disengages the starter motor when the engine oil pressure rises above the configured level for longer than the configured <i>Delay</i> .
Charge Alternator	<input type="checkbox"/> = The DSE module does not use charge alternator voltage to decide when to disengage the starter motor. <input checked="" type="checkbox"/> = The DSE module disengages the starter motor when the charge alternator voltage rises above the configured level.

2.9.10 SPEED SETTINGS

Under Speed Shutdown

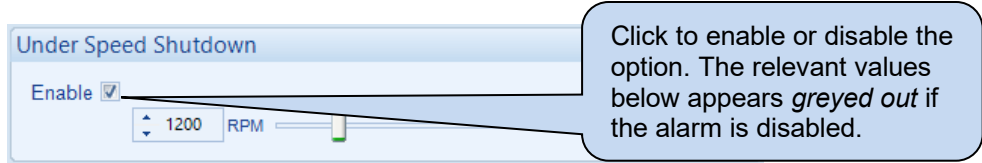

Parameter	Description
Under Speed Alarm	<input type="checkbox"/> = <i>Under Speed</i> alarm is disabled <input checked="" type="checkbox"/> = Under Speed gives an alarm in the event of the engine speed falling below the configured <i>Under Speed Alarm Trip</i> value for longer than the <i>Generator Transient Delay</i> . The <i>Underspeed Alarm Trip</i> value is adjustable to suit user requirements.

Over Speed Shutdown

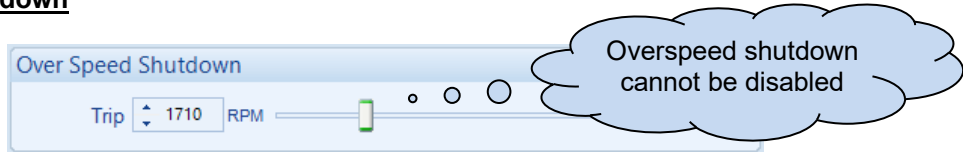

Parameter	Description
Over Speed Alarm	Over Speed gives a <i>Shutdown</i> alarm in the event of the engine speed rising above the configured <i>Over Speed Alarm Trip</i> value for longer than the <i>Generator Transient Delay</i> . The <i>Over Speed Alarm Trip</i> value is adjustable to suit user requirements.

2.9.11 PLANT BATTERY

Voltage Alarms

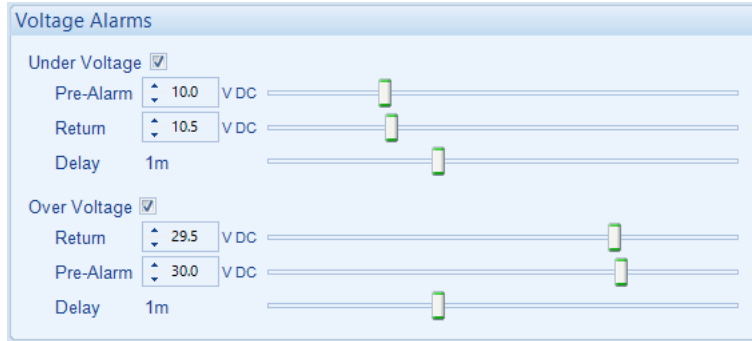

Parameter	Description
Plant Battery Under Voltage IEEE 37.2 -27 DC Undervoltage Relay	<input type="checkbox"/> = The alarm is disabled. <input checked="" type="checkbox"/> = The alarm activates when the battery voltage drops below the configured <i>Pre-Alarm</i> level for the configured <i>Delay</i> time. When the battery voltage rises above the configured <i>Return</i> level, the alarm is deactivated.
Plant Battery Over Voltage IEEE 37.2 -59 DC Overvoltage Relay	<input type="checkbox"/> = The alarm is disabled. <input checked="" type="checkbox"/> = The alarm activates when the battery voltage rises above the configured <i>Pre-Alarm</i> level for the configured <i>Delay</i> time. When the battery voltage drops below the configured <i>Return</i> level, the alarm is deactivated.

Charge Alternator Alarms

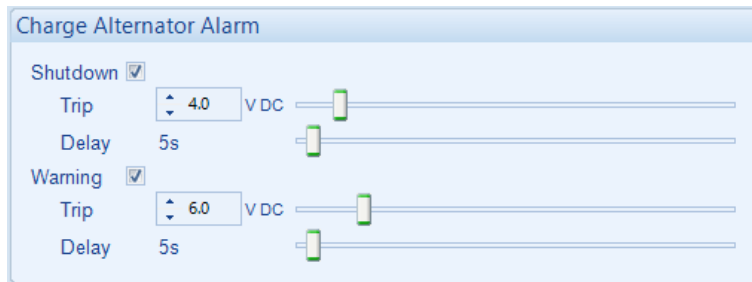

Parameter	Description
Charge Alternator Alarm	<input type="checkbox"/> = The alarm is disabled. <input checked="" type="checkbox"/> = The alarm activates when the charge alternator voltage falls below the configured <i>Trip</i> level for the configured <i>Delay</i> time.
Charge Alternator Pre-Alarm	<input type="checkbox"/> = The alarm is disabled. <input checked="" type="checkbox"/> = The alarm activates when the charge alternator voltage falls below the configured <i>Trip</i> level for the configured <i>Delay</i> time.

Start on Low Battery

Start On Low Battery

Enable

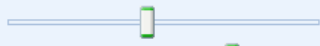
Threshold VDC 

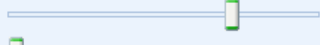
Engine Run Duration 1h 

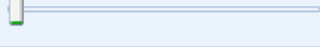
Start Delay 5s 

Alarm	Description
Start on Low Battery	<input type="checkbox"/> = <i>Start on Low Battery</i> is disabled. <input checked="" type="checkbox"/> = Select to enable autostart upon the battery voltage falling below the <i>Threshold</i> level for the duration of the <i>Start Delay</i> timer. The engine starts and run for the specified <i>Engine Run Duration</i> . This occurs only if the module is in AUTO mode

2.10 SCHEDULER

The scheduler is used to automatically start the set at a configured day and time and run it for the configured duration of hours.

The generator is made to run *on load* or *off load* depending upon the configuration :

The screenshot shows the 'Exercise Scheduler' configuration window. At the top, there is a title bar 'Exercise Scheduler'. Below it, there are four main settings: 'Enabled' with a checked checkbox, 'Scheduled runs are On Load' with an unchecked checkbox, and 'Schedule Period' set to 'Monthly' in a dropdown menu. Below these are eight rows of configuration for individual runs. Each row has four columns: 'Week' (dropdown menu set to 'First'), 'Day' (dropdown menu set to 'Monday'), 'Start Time' (spinners set to '00:00'), and 'Duration' (spinners set to '00:00'). To the right of each row is a 'Clear' button.

Function	Description
Enabled	<input type="checkbox"/> = Scheduled runs are disabled <input checked="" type="checkbox"/> = Scheduled runs are enabled based on the below settings.
Scheduled Runs	Determines the loading state mode of the generator when running on schedule <input type="checkbox"/> = The module runs the generator on schedule with the load switch open <input checked="" type="checkbox"/> = The module runs the generator on schedule and closes the load switch
Schedule Period	Determines the repeat interval for the scheduled run. Options available are: Weekly, Monthly
Week	Specifies the week of the month, on which the scheduled run takes place
Day	Specifies the day of week, on which the scheduled run takes place
Start Time	Determines at what time of day the scheduled run starts
Duration	Determines the time duration in hours for the scheduled run
Clear	Resets the values for the Day, Start Time and Duration to defaults

2.11 MAINTENANCE ALARM

Maintenance Alarm Oil, Air and Fuel

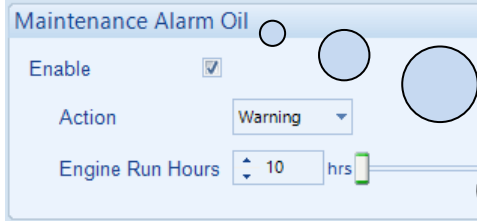

There are three ways to reset the maintenance alarm:

- 1) Activate a digital input configured to "Maintenance Reset Alarm".
- 2) Use the SCADA | Maintenance | Maintenance Alarm section of this PC Software.
- 3) Through the Front Panel Editor of the module

Function	Description
Enable	<input type="checkbox"/> = The maintenance alarm is disabled. <input checked="" type="checkbox"/> = The maintenance alarm is activated with the configured <i>Action</i> when the engine hours increase more than the <i>Engine Run Hours</i>
Action	<p>▲ NOTE: For details of these, see the section entitled <i>Alarm Types</i> elsewhere in this document.</p> <p>Select the type of alarm required from the list: Shutdown Warning</p>
Engine Run Hours	The value the engine hours must increase by to trigger the maintenance alarm.

2.12 ALTERNATIVE CONFIGURATIONS

An Alternative Configuration is provided to allow the system designer to cater for different AC requirements utilising the same generator system. Typically this feature is used by Rental Set Manufacturers where the set is capable of being operated at (for instance) 120 V 50 Hz and 240 V 50 Hz using a selector switch.

The Alternative Configuration is selected using either:

- Configuration Suite Software (Selection for 'Default Configuration')
- Module Front Panel Editor
- Via external signal to the module input configured to "Alternative Configuration" select.

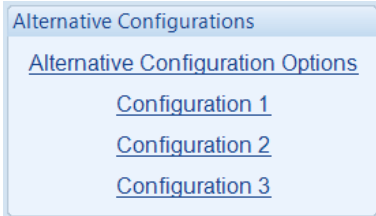

2.12.1 ALTERNATIVE CONFIGURATION OPTIONS

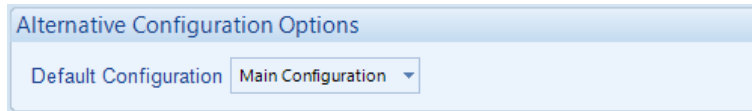

Parameter	Description
Default Configuration	Select the 'default' configuration that is used when there is no instruction to use an 'alternative configuration'.

2.12.2 ALTERNATIVE CONFIGURATION 1 TO 3

The Alternative Configurations Editor allows for editing of the parameters that are to be changed when an Alternative Configuration is selected.

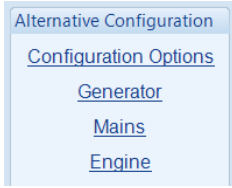

2.12.2.1 CONFIGURATION OPTIONS

Enable Alternative Configuration

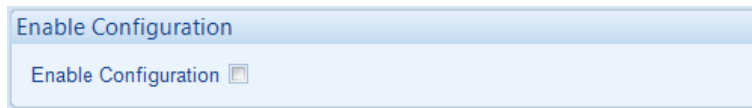

Parameter	Description
Enable Configuration	<input type="checkbox"/> = <i>Alternative Configuration</i> is disabled. <input checked="" type="checkbox"/> = <i>Alternative Configuration</i> is enabled. The configuration is enabled by changing the <i>Default Configuration</i> , activating a digital input or through the module's <i>Front Panel Editor</i> .

2.12.2.2 GENERATOR / MAINS / ENGINE

Alternative configuration options contain a subset of the main configuration. The adjustable parameters are not discussed here as they are identical to the main configuration options :

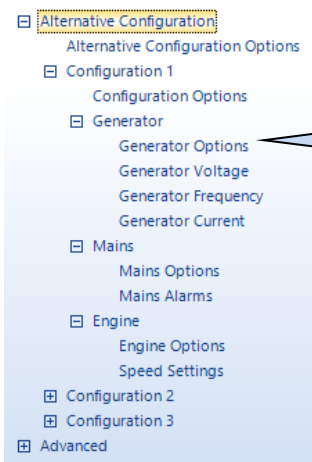

Configuration menus for the *Alternative Configuration*. For information about the configuration items within this section, refer to their description in the 'main' configuration.

2.13 ADVANCED

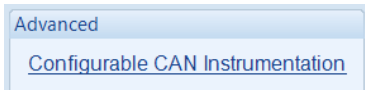

2.13.1 CONFIGURABLE CAN INSTRUMENTATION

The *Configurable CAN Instrumentation* section is subdivided into smaller sections. Select the required section with the mouse.

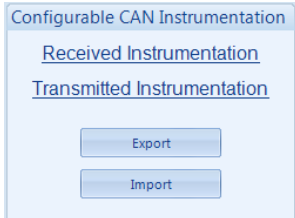

2.13.2 RECEIVED INSTRUMENTATION

This feature allows for up to ten custom engine CAN instrumentation items to be decoded from CAN messages on the connected ECU port.

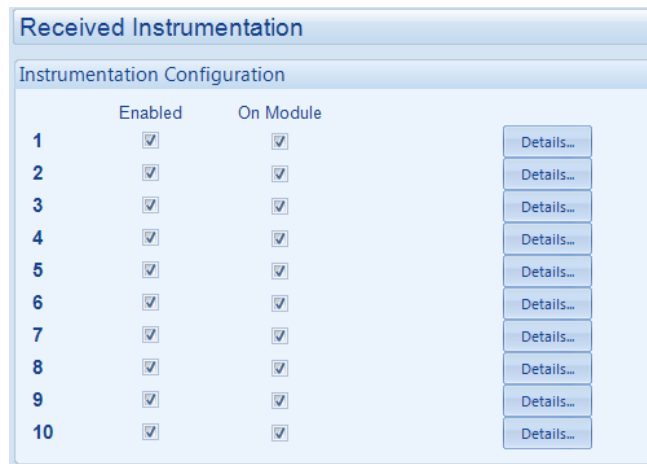

Parameter	Description
Enabled	<p>▲ NOTE: The CAN instrumentation must already be available on the CAN bus. There is no request for a non-standard instrumentation.</p> <p><input type="checkbox"/> = The CAN instrumentation is disabled. <input checked="" type="checkbox"/> = The CAN instrumentation is enabled. Reading depends upon the message availability on the bus.</p>
On Module	<p>▲ NOTE: The CAN instrumentation is always available on the Scada as long as at least one CAN instrumentation is enabled. The CAN instrumentation is shown on the module's display when the <i>On Module</i> is enabled.</p> <p><input type="checkbox"/> = The CAN instrumentation is not displayed on the module. <input checked="" type="checkbox"/> = The CAN instrumentation is displayed on the module.</p>
Details	Click on Details to set the <i>Message Decoding CAN</i> options.

2.13.2.1 DETAILS

Message Identification

Parameter	Description
Message Type	Select the required message type: 11 Bit: message identifier for standard CAN 29 Bit: message identifier for extended CAN
Message ID	CAN message ID
Enabled	<input type="checkbox"/> = Timeout is disabled <input checked="" type="checkbox"/> = Timeout is enabled
Timeout	It indicates how often the messages are expected to be seen on the CAN bus. If no new instrumentation is seen beyond the timeout period, the calculated instrumentation value changes to a 'bad data' sentinel value.

Data Structure

Parameter	Description
Offset Byte	Set the start position Byte
Offset Bit	Set the start position Bit
Length (Bits)	Data length 1-32 bits
Signed Value	<input type="checkbox"/> = Unsigned value <input checked="" type="checkbox"/> = Signed value

Parameter descriptions are continued overleaf...

Display

NOTE: If the received CAN instrument is outside the configured raw values, the module displays sentinel value.

Parameter	Description
Decimal Places	Display the decimal point. 0 represents 0 scaling factor, 1 represents 0.1 scaling factor, -1 represents 10 multiplier.
Suffix	Unit display (example: m ³ /hr)
Smallest Raw Value	The smallest data sent over the CAN bus before the transformations (decimal places).
Maps To	The output format after all transformations including decimal point shift) as to be shown on the module screen, or SCADA, in data log file, etc.
Largest Raw Value	The largest data sent over the CAN bus before the transformations (decimal places).
Maps To	The output format after all transformations including decimal point shift) as to be shown on the module screen, or SCADA, in data log file, etc.

Test

Parameter	Description
Test Raw Value	<p>NOTE: The Test Raw Value is not saved in the configuration, this is only to check the displayed value.</p> <p>This is a test case to check the representation of the <i>Raw Value</i> when they are complicated. <i>Test Raw Value</i> is the value read from the CAN bus before the transformation</p>
Displayed Value	The <i>Test Raw Value</i> 's represented value as to be shown on the DSE module's screen, or in the Scada.

2.13.3 TRANSMITTED INSTRUMENTATION

The module allows transmitting up to five instruments over the CANbus on the ECU port by specifying the source address (message ID) of the selected Instrument.

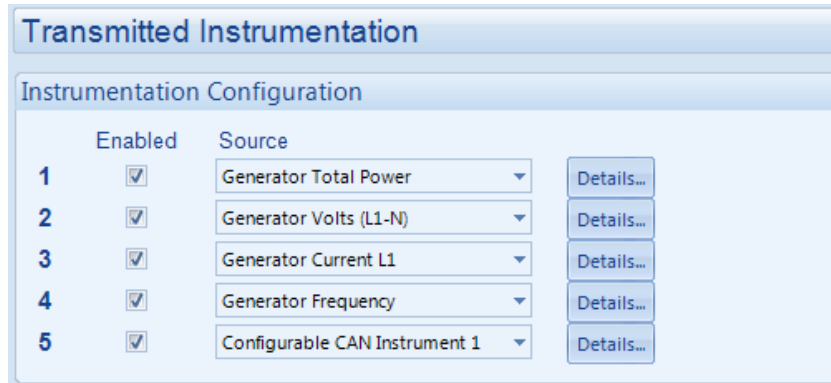

Parameter	Description
Enabled	<input type="checkbox"/> = The Transmit CAN instrumentation is disabled. <input checked="" type="checkbox"/> = The Transmit CAN instrumentation is enabled.
Source	Select the instrument to be created over the CAN.
Details	Click on Details to set the <i>Message Encoding</i> CAN options.

2.13.3.1 DETAILS

Message Identification

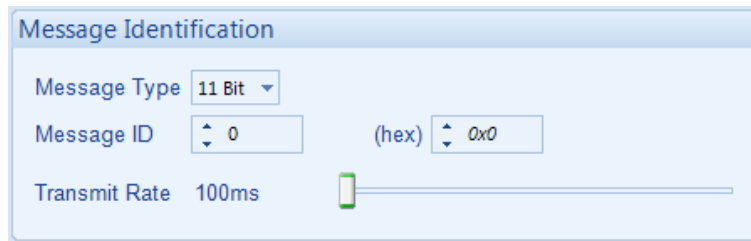

Parameter	Description
Message Type	Select the required message type to transmit: 11 Bit: message identifier for standard CAN 29 Bit: message identifier for extended CAN
Message ID	CAN message ID
Transmit Rate	The rate at which the <i>CAN Instrument</i> is transmitted over the CANbus.

Parameter descriptions are continued overleaf...

Data Structure

Data Structure

Offset Byte Bit

Length (Bits)

Signed Value

Parameter	Description
Offset Byte	Set the start position Byte
Offset Bit	Set the start position Bit
Length (Bits)	Data length 1-32 bits
Signed Value	<input type="checkbox"/> = Transmit unsigned value <input checked="" type="checkbox"/> = Transmit signed value

Mapping

Mapping

Smallest Source Value Maps To

Largest Source Value Maps To

Parameter	Description
Smallest Source Value	The smallest instrument value before being sent over the CAN bus.
Maps To	The transmitted format for the <i>Smallest Source Value</i> .
Largest Source Value	The largest instrument value before being sent over the CAN bus.
Maps To	The transmitted format for the <i>Largest Source Value</i> .

Test

Test

Source Value

Mapped Value 0

Parameter	Description
Source Value	<div style="border: 2px solid black; padding: 5px;"> <p>▲ NOTE: The Source Value is not transmitted over the CANbus, this is only to check the encoded value.</p> </div> <p>This is a test case to check the representation of the <i>Source Value</i> when they are complicated. <i>Source Value</i> is the instrument value before being encoded.</p>
Mapped Value	The <i>Mapped Value</i> represents the transmitted <i>Source value</i> .

2.13.4 CONFIGURABLE CAN INSTRUMENTATION EXPORT/IMPORT

This feature is used to import the *Configurable CAN Instrumentation* settings in another module.



Parameter	Description
Export	This allows the configuration settings of all Configurable CAN Instrumentation (Received & Transmitted) into one XML file.
Import	This allows to import an existing configuration settings of all Configurable CAN Instrumentation saved in XML format.

3 SCADA

SCADA stands for **S**upervisory **C**ontrol **A**nd **D**ata **A**cquisition and is provided both as a service tool and also as a means of monitoring / controlling the generator set.

As a service tool, the SCADA pages are to check the operation of the controller's inputs and outputs as well as checking the generators operating parameters.

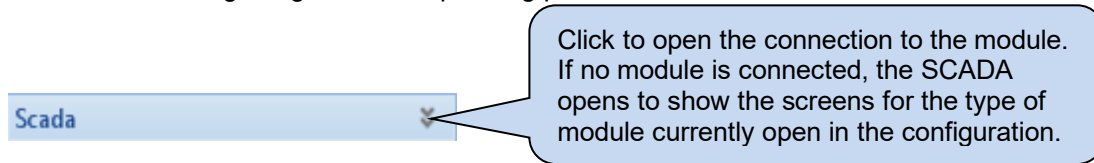

When connection is made...

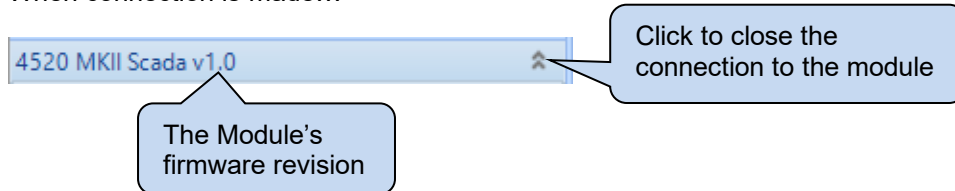

The SCADA page is subdivided into smaller sections. Select the required section with the mouse.

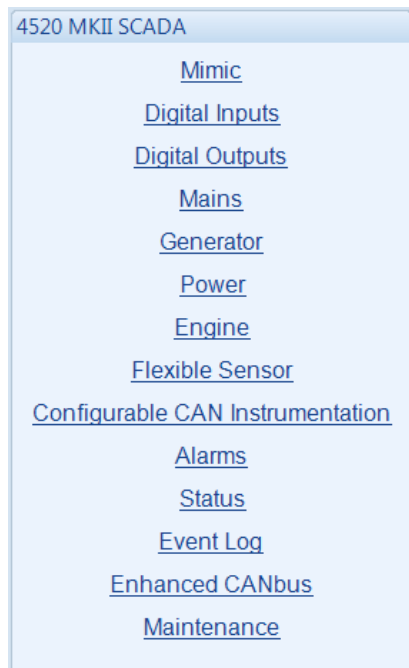

3.1 MIMIC

This screen provides a mimic of the control module and allows the operator to change the control mode of the module.

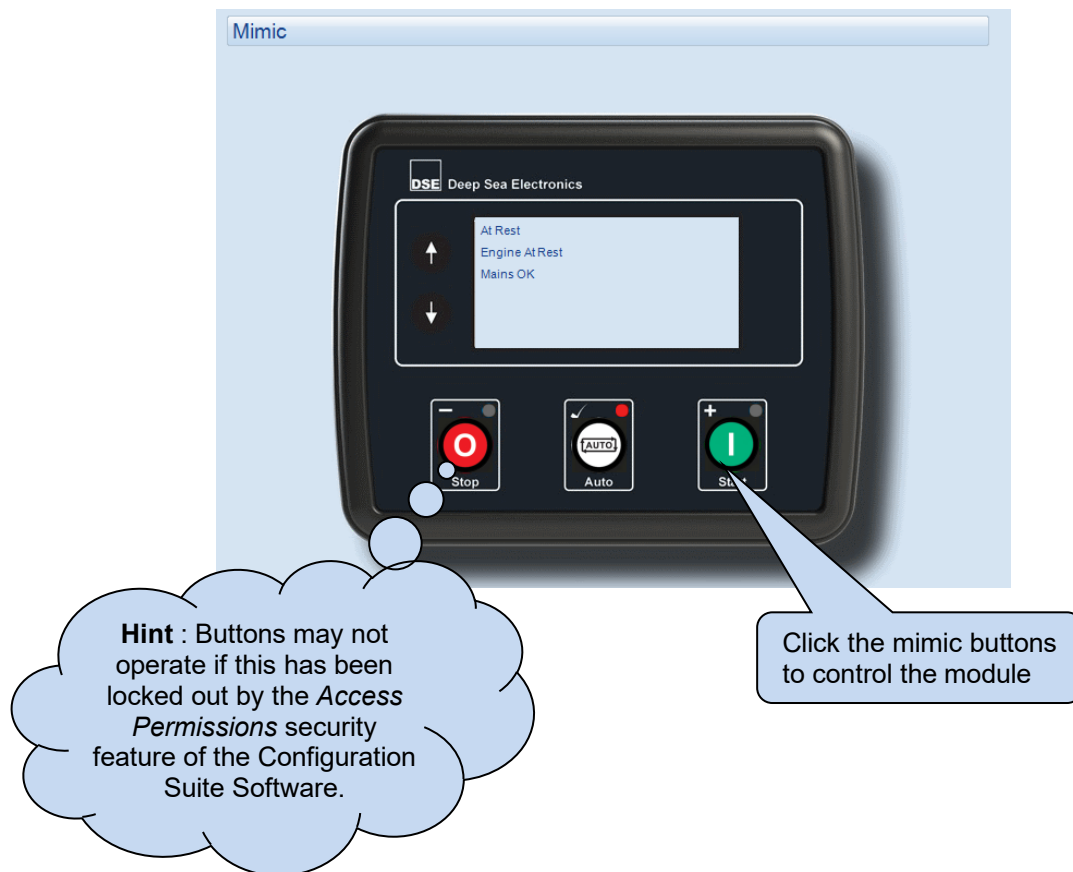

3.2 DIGITAL INPUTS

This section displays the status of the module's digital inputs and the functions they are configured for. For further details on how to configure these items, refer to section entitled *Digital Inputs* elsewhere within this document.

The screenshot shows a SCADA interface titled "Digital Inputs". It contains a table with the following data:

	Active	Open / Closed
A Remote Start On Load	●	⏏
B Emergency Stop	●	⏏
C Alarm Reset	●	⏏
D Digital Input D	●	⏏

Two callout boxes provide additional information:

- The first callout points to the "Active" column and states: "Shows if the digital input is active or not."
- The second callout points to the "Open / Closed" column and states: "State of the input (open or closed to battery negative)".

3.3 DIGITAL OUTPUTS

This section displays the status of the module's digital outputs and the functions they are configured for. For further details on how to configure these items, refer to section entitled *Digital Outputs* elsewhere within this document.

The screenshot shows a SCADA interface titled "Digital Outputs". It contains a table with the following data:

	Active	Open / Closed
A Fuel Relay	●	⏏
B Start Relay	●	⏏
C Close Gen Output	●	⏏
D Close Mains Output	●	⏏
E Common Warning	●	⏏
F Common Electrical Trip	●	⏏

Two callout boxes provide additional information:

- The first callout points to the "Active" column and states: "Shows if the output channel is active or not."
- The second callout points to the "Open / Closed" column and states: "State of the output (open or closed)".

3.4 MAINS



= Only available on DSE4520 MKII Modules

This section displays the module's measurement of the *Generator* frequency, voltage and current supply.

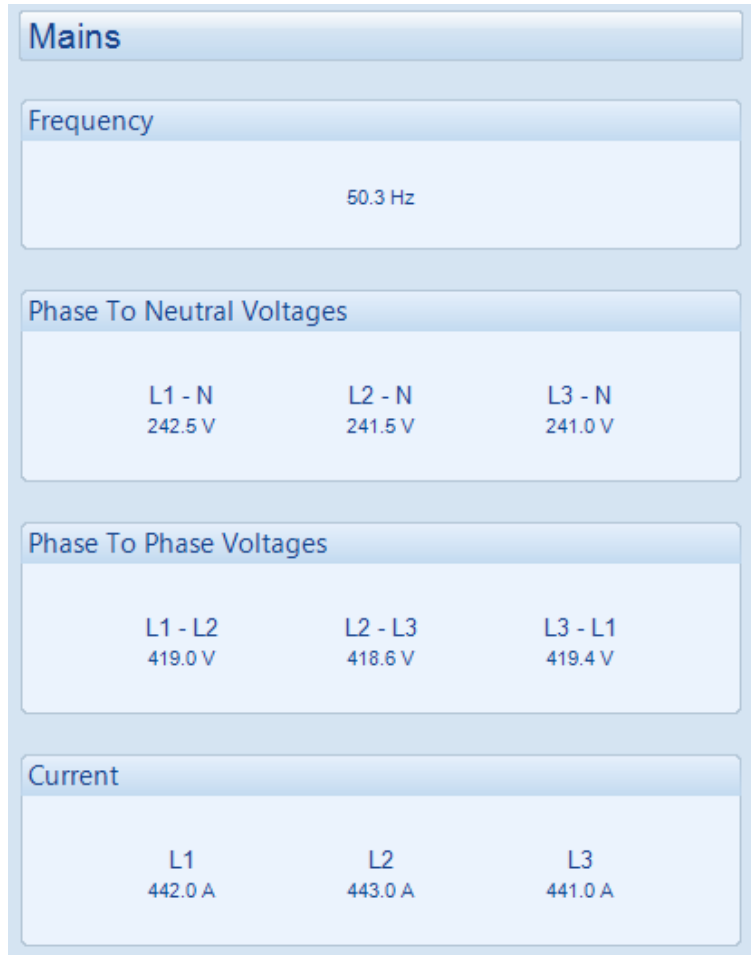

3.5 GENERATOR

This section displays the module's measurement of the *Generator* frequency, voltage and current supply.

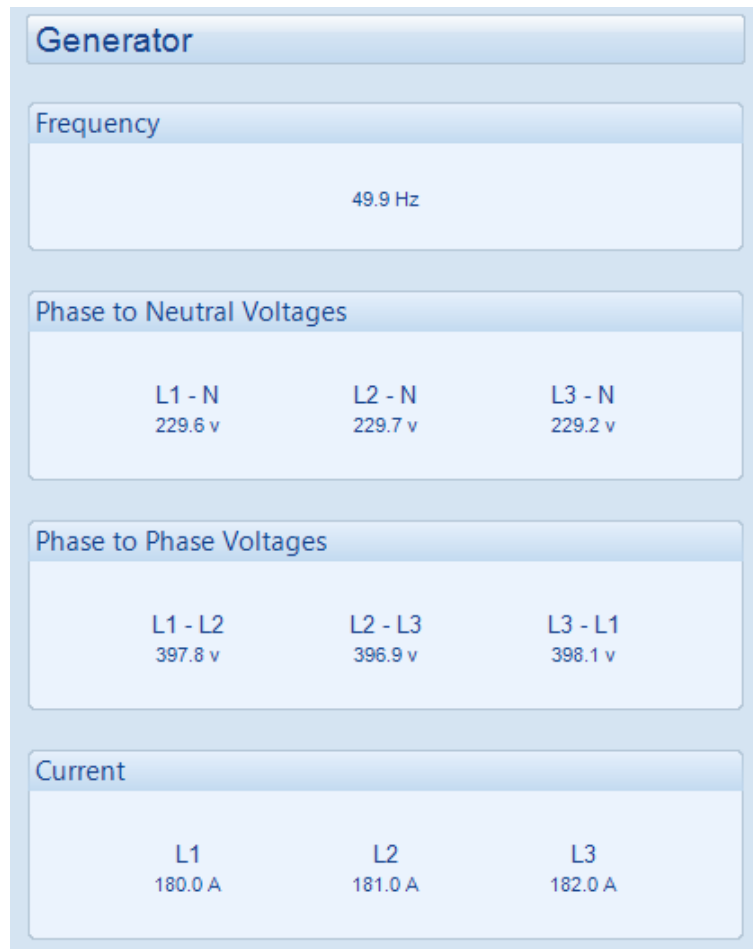

3.6 POWER

This section displays the module's measurement of the *Generator* or *Mains* power output.

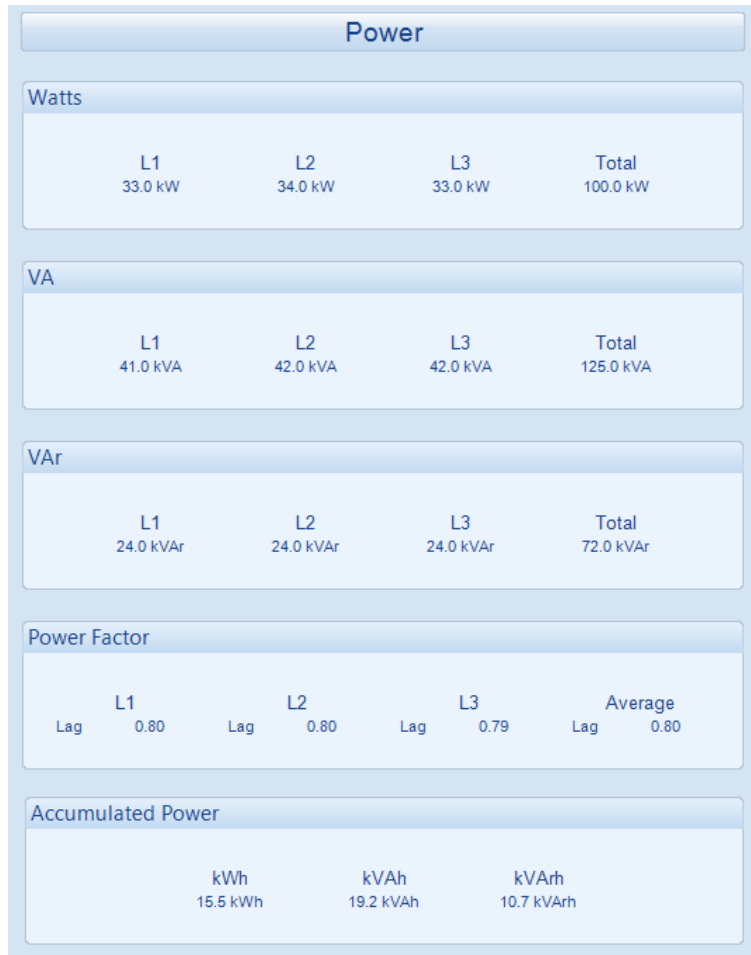

3.7 ENGINE

This section displays the measurement of the *Engine* parameters. These measurements come from either the module's inputs or from the engine ECU/ECM. For further details on how to configure these items, refer to section entitled *Application* elsewhere within this document.



3.8 FLEXIBLE SENSOR

This section displays the status and instrumentation measured by the module's analogue inputs and the functions they are configured for. For further details on how to configure these items, refer to section entitled *Fuel Level* elsewhere within this document.

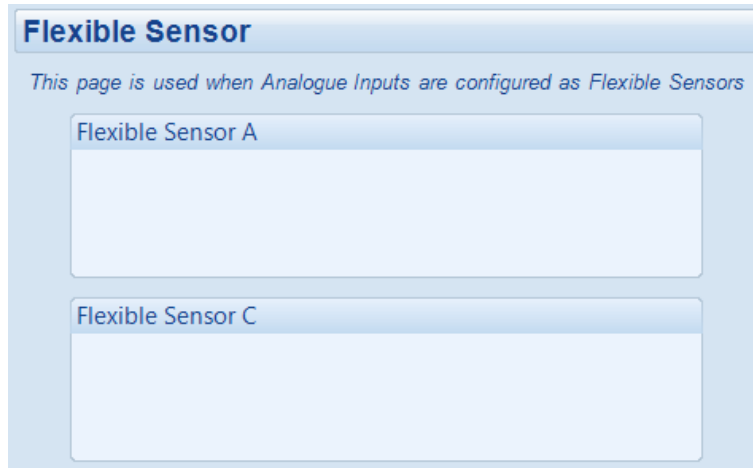

3.9 CONFIGURABLE CAN INSTRUMENTATION

Shows the module's readings of the configured *CAN Instrumentation*. This is only available if the module is configured for *Configurable CAN Instrumentation*, the *Enhanced Canbus* option is enabled, and the message is available over the relevant configured CAN bus.

Configurable CAN Instrumentation		
Configurable CAN Instrumentation		
1	Longitude - VP	210.0072902
2	Engine Oil Pressure - EFL_P1	124 kPa
3	Latitude - VP	1.0036625
4	Engine Coolant Pressure - EFL_P1	234 kPa
5	Engine Fuel Pressure - EFL_P1	0 kPa
6	Engine Hours - HOURS	1000.0 hr
7	Engine Oil Temperature 1 - ET1	84.37042 deg C
8	Engine Coolant Temperature - ET1	55 deg C
9	Engine Fuel Rate - LFE	10.00 L/h
10	Electrical Potencial Plnp - VEP1	0.00 V

3.10 ALARMS

This section displays the alarms that are currently active on the module. For information in regards to alarm descriptions, refer to DSE publication: **057-260 DSE4510 MKII & DSE4520 MKII Operator Manual** found DSE's the DSE website: www.deepseaelectronics.com.

For information in regards to alarm severity, refer to section entitled *Alarm Types* elsewhere within this document.



3.11 STATUS

This section displays the status information about the module

Status	
Supervisor State At Rest	Software Version 1.0
Engine/Generator State Engine At Rest	Module ID BC614E
Mains Detection State Mains OK	Mode 
Load Switching State Closed To Mains	
Heater Fitted Heater Fitted	

3.12 EVENT LOG

This section displays the events which are recorded with the module's event log along with the time, date and engine hours in which they occurred. For further details on how what events are recorded, refer to section entitled *Event Log* elsewhere within this document.

For information in regards to alarm descriptions, refer to DSE publication: **057-260 DSE4510 MKII & DSE4520 MKII Operator Manual** found DSE's the DSE website: www.deepseaelectronics.com.

Event Log					
#	Date	Time	Hours Run	Event	Details
1	28/03/2013	12:01	0:00	Shutdown	Emergency Stop
2	28/03/2013	11:58	0:00	Restart	Power Up
3	28/03/2013	11:54	0:00	Shutdown	Oil Pressure Sensor Open Circuit
4	28/03/2013	11:54	0:00	Restart	Power Up

3.13 ENHANCED CANBUS

This section displays the measurement of the *Engine* parameters. These measurements come from the engine ECU/ECM. For further details on how to configure engine ECU/ECM, refer to section entitled *Application* elsewhere within this document.

<p>Engine Oil Temperature</p> <p>80 °C, 176 °F</p>	<p>Inlet Temperature</p> <p>Temp. 1 Temp. 2</p> <p>33 °C, 91 °F</p>
<p>Exhaust Temperature</p> <p>Temp. 1 Temp. 2</p>	<p>Coolant Pressure</p> <p>Press. 1 Press. 2</p>
<p>Fuel Pressure</p> <p>Press. 1 Press. 2</p> <p>4.88Bar, 71 PSI, 488 kPa</p>	<p>Turbo Pressure</p> <p>Press. 1 Press. 2</p> <p>0.22Bar, 3 PSI, 22 kPa</p>

3.14 MAINTENANCE

The *Maintenance* section is subdivided into smaller sections. Select the required section with the mouse.



3.14.1 MAINTENANCE ALARM RESET

This section allows the module's three maintenance alarms to be reset and when the alarm is due to activate.

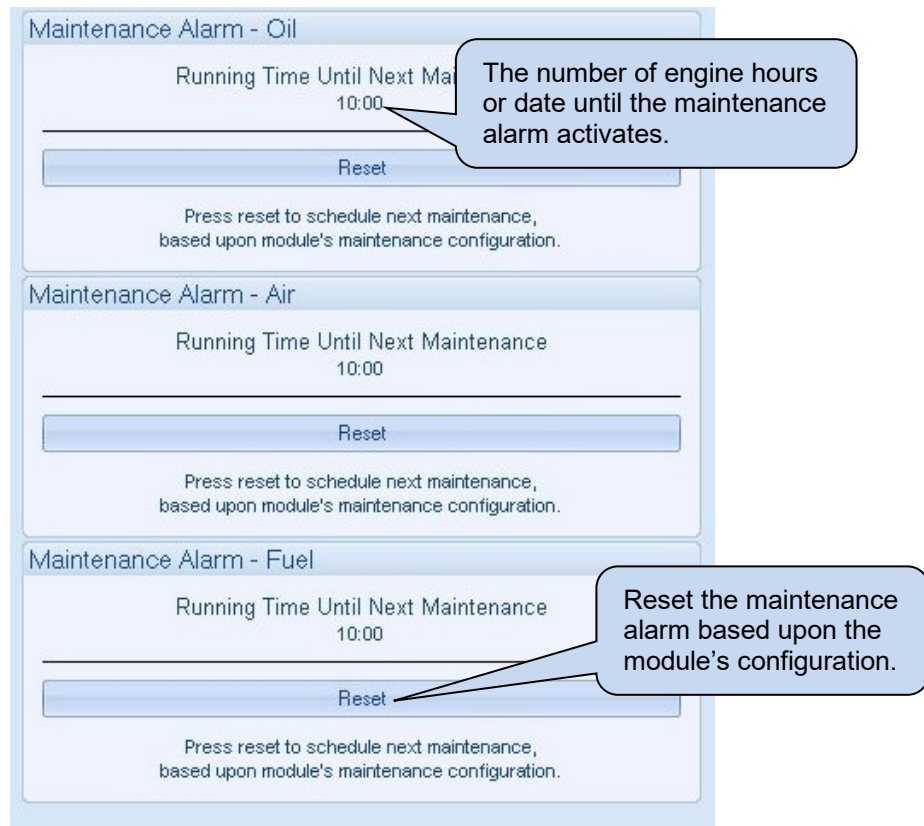

3.14.2 HOURS RUN AND NUMBER OF STARTS

This section allows the Hours Run and Number of Starts to be customised on the controller. Typically, this is used when fitting a new controller to an older engine so that the controller display matches the amount of work previously done by the system.

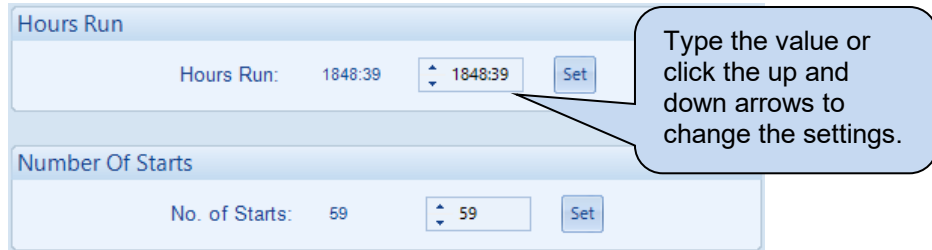

3.14.3 DATE AND TIME

This section allows the date and time to be adjusted on the controller.

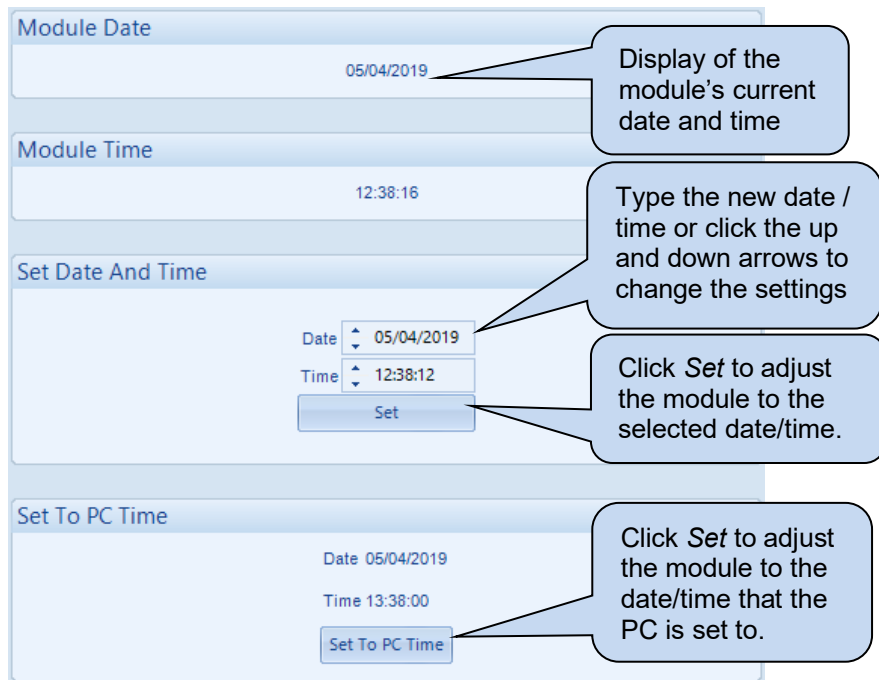

3.14.4 ACCUMULATED INSTRUMENTATION

This section allows the generators accumulated instrumentation to be adjusted on the controller.

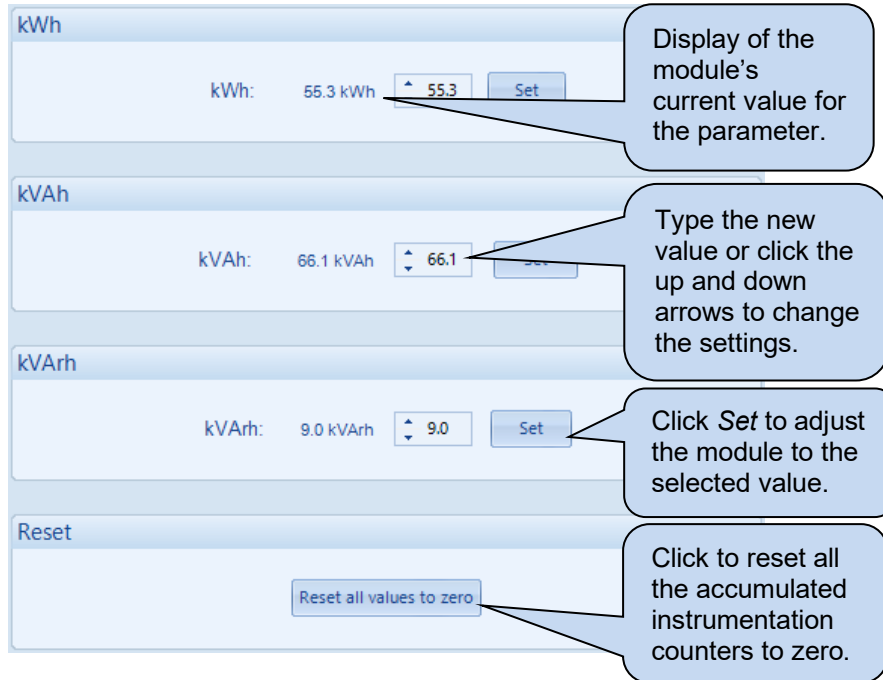

The screenshot displays the 'ACCUMULATED INSTRUMENTATION' control panel. It is divided into four horizontal sections: kWh, kVAh, kVArh, and a Reset section. Each section shows a current value (e.g., 55.3 kWh) and a numeric input field with up and down arrows. A 'Set' button is located to the right of each input field. At the bottom, there is a 'Reset all values to zero' button. Callout boxes provide the following instructions:

- Display of the module's current value for the parameter. (points to the kWh value)
- Type the new value or click the up and down arrows to change the settings. (points to the kVAh input field)
- Click Set to adjust the module to the selected value. (points to the kWh Set button)
- Click to reset all the accumulated instrumentation counters to zero. (points to the Reset button)

3.14.5 DPF REGENERATION

This section allows settings within the engine's ECU to be altered when supported.

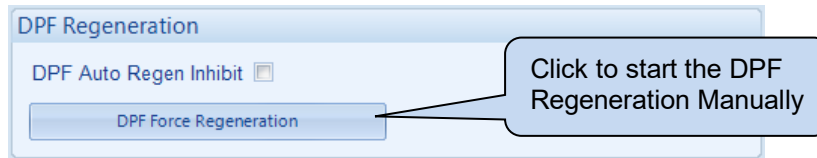

The screenshot shows the 'DPF Regeneration' control panel. It includes a 'DPF Auto Regen Inhibit' checkbox and a 'DPF Force Regeneration' button. A callout box points to the 'DPF Force Regeneration' button with the text: 'Click to start the DPF Regeneration Manually'.

Parameter	Description
DPF Auto Regen Inhibit	<input type="checkbox"/> = The ECU's DPF Auto Regeneration happens automatically. <input checked="" type="checkbox"/> = The ECU's DPF Auto Regeneration is inhibited from activating.

3.14.6 MODULE PIN

⚠ CAUTION!: If the module PIN is lost or forgotten, it is no longer possible to access or make changes to the module!

This section allows the user to configure a PIN (Personal Identification Number) within the module. This PIN must be entered to access the modules *Main Front Panel Configuration Editor* or, when writing a configuration / changing a value in SCADA using the DSE Configuration Suite PC Software.

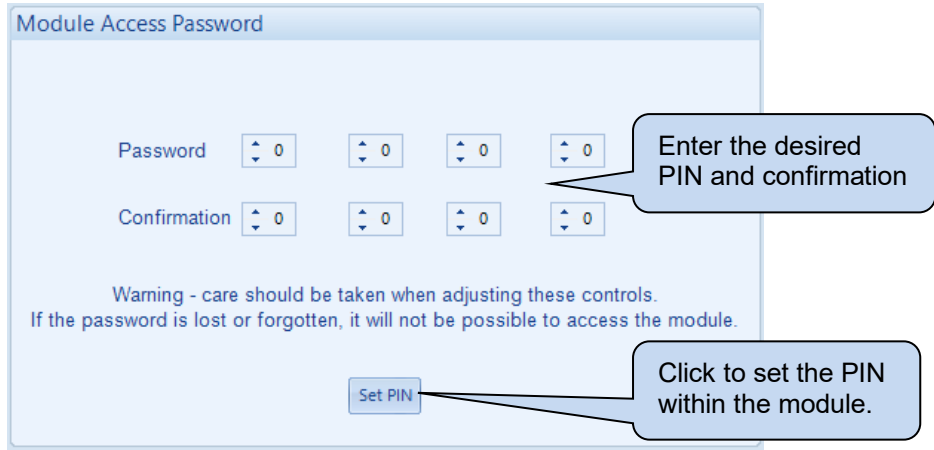

3.14.7 LCD CONTRAST

This section allows the user to adjust the module's display contrast. This is useful when the contrast is set to a level where the display is no longer visible and therefore cannot be configured through the Front Panel Editor.

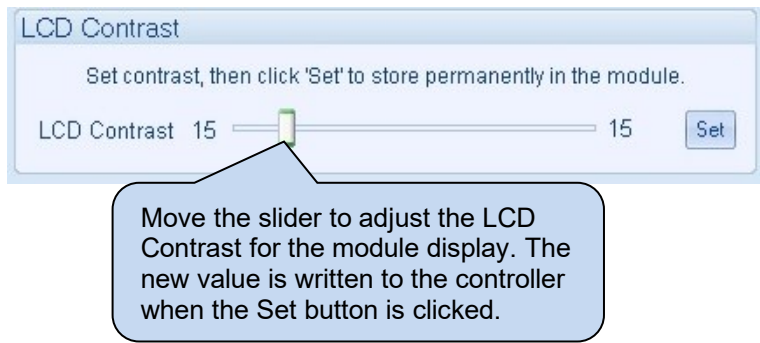

4 ALARM TYPES

The protection included with the DSE control modules provides increasing levels of notification, depending upon the severity of the situation:

Alarm type	Description
Indication	No audible alarm or common warning signal occurs. <i>Indication</i> alarms are only used to illuminate indicators or to activate outputs.
Warning	Audible alarm and common alarm signal is generated. The set continues to run. <i>Warning alarms</i> are used to draw the operator's attention to a minor issue or to a problem that may escalate to an Electrical Trip or Shutdown Alarm if left untreated.
Electrical Trip	Audible alarm and common alarm signal is generated. The set is taken off load and the cooling timer begins, after which the set is stopped. <i>Electrical Trip alarms</i> are series issues that require the set to be taken off load. As the name implies, this is often electrical faults that occur 'after' the load switch. The set is allowed to cool before stopping.
Shutdown	Audible alarm and common alarm signal is generated. The set is taken off load and immediately stopped. <i>Shutdown alarms</i> are serious issues that demand immediate stopping of the generator. For instance Emergency Stop or Overspeed alarms require immediate shutdown.

5 ALARM ARMING

The protections on the DSE module are active during their configured *Alarm Arming* setting. The table below shows the timing segment for the different *Alarm Arming* options with regards to the the generator status.

Timing Segment	Stopped	Start Delay	ECU Wake Up Delay	Preheat	Cranking	Safety on Delay	Smoke Limiting	Smoke Limiting Off	Warming Up	Gen Available	Gen On Load	Cooling	Cooling in Idle
Never													
Always													
When Stationary													
From Starting													
Overfrequency / Overspeed Overshoot													
From Safety On													

5.1 NEVER

The protection is never active on the controller. This is used to disable the protection.

5.2 ALWAYS

The protection is always active on the controller. This is used to constantly monitor statuses such as a fuel level switch irrespective of the engine running state.

5.3 WHEN STATIONARY

The protection is active from the moment the engine stops until the beginning of engine cranking.

5.4 FROM STARTING

The protection is active from the beginning of engine cranking, until the engine stops.

5.5 OVERSHOOT

Active during the *Safety Delay* timer, this allows for a temporary raise of the overspeed/overfrequency trip points during start-up.

Protection Level	Over Frequency Trip Level	Over Speed Trip Level
Immediate Shutdown	Over Frequency + Overshoot %	Over Speed + Overshoot %
Delayed Shutdown (Overspeed Overshoot Delay)	Over Frequency	Over Speed

Example

57 Hz *Over Frequency* setting, 10% *Overspeed Overshoot*

During *Safety Delay* a generator frequency above $(57 \text{ Hz} \times 1.1) = 62.7 \text{ Hz}$ results in an immediate shutdown without delay.

After *Safety delay*, a generator frequency above 57 Hz for the period of the *Generator Transient Delay* results in a shutdown

5.6 FROM SAFETY ON

The protection is active when the set is running at nominal speed, until the engine stops.

This Page Intentionally Blank

This Page Intentionally Blank